



POWER-MOS FET

FIELD EFFECT POWER TRANSISTOR

IRF450,451 D86FR2,R1
13 AMPERES 500, 450 VOLTS R_{DS(ON)} = 0.4 Ω

This series of N-Channel Enhancement-mode Power MOSFETs utilizes GE's advanced Power DMOS technology to achieve low on-resistance with excellent device ruggedness and reliability.

This design has been optimized to give superior performance in most switching applications including: switching power supplies, inverters, converters and solenoid/relay drivers. Also, the extended safe operating area with good linear transfer characteristics makes it well suited for many linear applications such as audio amplifiers and servo motors.

Features

- Polysilicon gate — Improved stability and reliability
- No secondary breakdown — Excellent ruggedness
- Ultra-fast switching — Independent of temperature
- Voltage controlled — High transconductance
- Low input capacitance — Reduced drive requirement
- Excellent thermal stability — Ease of paralleling

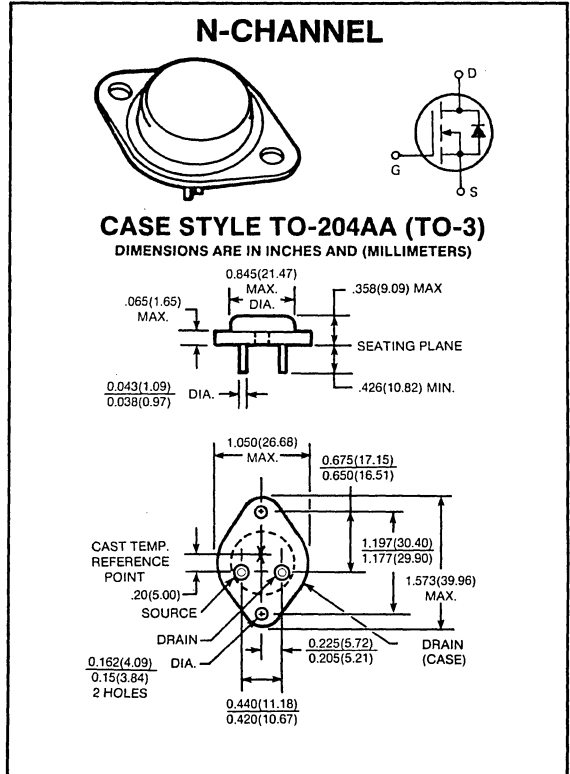

maximum ratings ($T_C = 25^\circ\text{C}$) (unless otherwise specified)

RATING	SYMBOL	IRF450/D86FR2	IRF451/D86FR1	UNITS
Drain-Source Voltage	V_{DSS}	500	450	Volts
Drain-Gate Voltage, $R_{GS} = 1M\Omega$	V_{DGR}	500	450	Volts
Continuous Drain Current @ $T_C = 25^\circ\text{C}$ @ $T_C = 100^\circ\text{C}$	I_D	13 8	13 8	A A
Pulsed Drain Current ⁽¹⁾	I_{DM}	52	52	A
Gate-Source Voltage	V_{GS}	± 20	± 20	Volts
Total Power Dissipation @ $T_C = 25^\circ\text{C}$ Derate Above 25°C	P_D	150 1.2	150 1.2	Watts W/ $^\circ\text{C}$
Operating and Storage Junction Temperature Range	T_J, T_{STG}	-55 to 150	-55 to 150	$^\circ\text{C}$

thermal characteristics

Thermal Resistance, Junction to Case	$R_{\theta JC}$	0.83	0.83	$^\circ\text{C/W}$
Thermal Resistance, Junction to Ambient	$R_{\theta JA}$	30	30	$^\circ\text{C/W}$
Maximum Lead Temperature for Soldering Purposes: 1/8" from Case for 5 Seconds	T_L	260	260	$^\circ\text{C}$

(1) Repetitive Rating: Pulse width limited by max. junction temperature.

electrical characteristics ($T_C = 25^\circ\text{C}$) (unless otherwise specified)

CHARACTERISTIC	SYMBOL	MIN	TYP	MAX	UNIT
----------------	--------	-----	-----	-----	------

off characteristics

Drain-Source Breakdown Voltage ($V_{GS} = 0V, I_D = 250\ \mu\text{A}$)	IRF450/D86FR2 IRF451/D86FR1	BV_{DSS}	500 450	— —	— —	Volts
Zero Gate Voltage Drain Current ($V_{DS} = \text{Max Rating}, V_{GS} = 0V, T_C = 25^\circ\text{C}$) ($V_{DS} = \text{Max Rating}, \times 0.8, V_{GS} = 0V, T_C = 125^\circ\text{C}$)		I_{DSS}	— —	— —	250 1000	μA
Gate-Source Leakage Current ($V_{GS} = \pm 20V$)		I_{GSS}	—	—	± 100	nA

on characteristics*

Gate Threshold Voltage ($V_{DS} = V_{GS}, I_D = 250\ \mu\text{A}$)	$T_C = 25^\circ\text{C}$	$V_{GS(TH)}$	2.0	—	4.0	Volts
On-State Drain Current ($V_{GS} = 10V, V_{DS} = 10V$)		$I_{D(ON)}$	13	—	—	A
Static Drain-Source On-State Resistance ($V_{GS} = 10V, I_D = 7A$)		$R_{DS(ON)}$	—	0.3	0.4	Ohms
Forward Transconductance ($V_{DS} = 10V, I_D = 7A$)		g_{fs}	4.8	7.0	—	mhos

dynamic characteristics

Input Capacitance	$V_{GS} = 0V$	C_{iss}	—	2800	3000	pF
Output Capacitance	$V_{DS} = 25V$	C_{oss}	—	330	600	pF
Reverse Transfer Capacitance	$f = 1\ \text{MHz}$	C_{rss}	—	55	200	pF

switching characteristics*

Turn-on Delay Time	$V_{DS} = 225V$	$t_{d(on)}$	—	25	—	ns
Rise Time	$I_D = 7A, V_{GS} = 15V$	t_r	—	20	—	ns
Turn-off Delay Time	$R_{GEN} = 50\ \Omega, R_{GS} = 12.5\ \Omega$	$t_{d(off)}$	—	120	—	ns
Fall Time	$(R_{GS} \text{ (EQUIV.)} = 10\ \Omega)$	t_f	—	65	—	ns

source-drain diode ratings and characteristics*

Continuous Source Current	I_S	—	—	13	A
Pulsed Source Current	I_{SM}	—	—	52	A
Diode Forward Voltage ($T_C = 25^\circ\text{C}, V_{GS} = 0V, I_S = 13A$)	V_{SD}	—	0.9	1.4	Volts
Reverse Recovery Time ($I_S = 13A, di_S/dt = 100A/\mu\text{sec}, T_C = 125^\circ\text{C}$)	t_{rr} Q_{RR}	—	590 7.4	—	ns μC

*Pulse Test: Pulse width $\leq 300\ \mu\text{s}$, duty cycle $\leq 2\%$

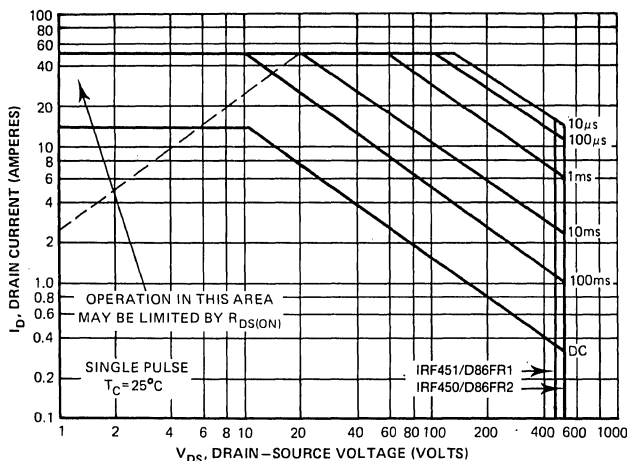

MAXIMUM SAFE OPERATING AREA

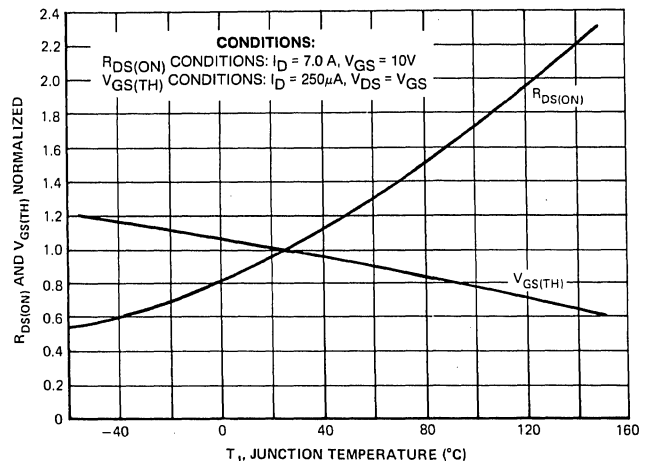

TYPICAL NORMALIZED $R_{DS(ON)}$ AND $V_{GS(TH)}$ VS. TEMP.