



# 5-CH MOTOR DRIVER D9259

## DESCRIPTION

The D9259 is a monolithic integrated circuit, and suitable for 5-ch motor driver which drives focus actuator, tracking actuator, sled motor, spindle motor and loading motor of CD system.

## FEATURE

- 1 phase, full-wave, linear DC motor driver.
- Built-in TSD (Thermal shutdown) circuit.
- Built-in 5V regulator (with an external PNP TR).
- Built-in mute circuit.
- Built-in loading motor speed control circuit.
- Wide operating supply voltage range: 6V~13.2V

Outline Drawing

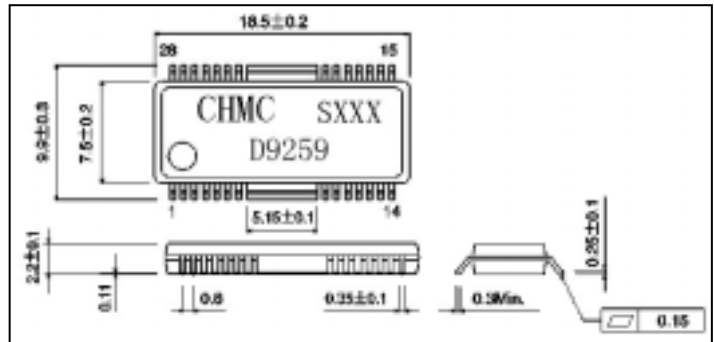

## TARGET APPLICATION

- CD-PLAY
- VIDEO-CD
- CAR-CD

## BLOCK DIAGRAM AND PIN CONNECTION

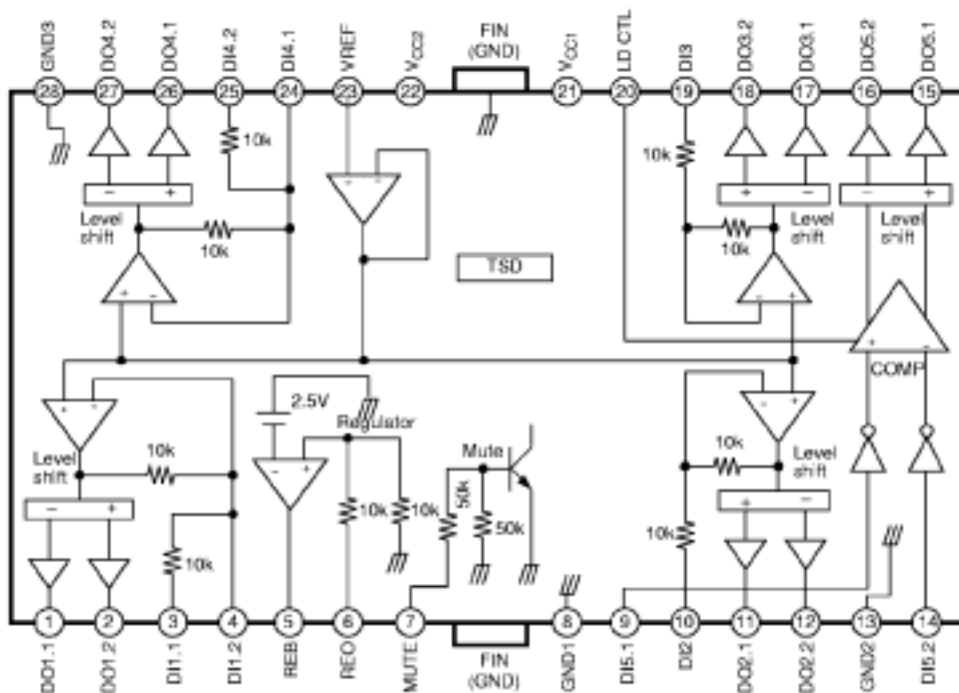

## PIN DESCRIPTION

Pin NO.	Symbol	I/O	Description	Pin NO.	Symbol	I/O	Description
1	DO1.1	O	Focus output 1 (-)	15	DO5.1	O	Loading output 1(+)
2	DO1.2	O	Focus output 2 ( + )	16	DO5.2	O	Loading output 2(-)
3	DI1.1	I	Focus input 1	17	DO3.1	O	Sled output ( - )
4	DI1.2	I	Focus input 2 ( Adjustable )	18	DO3.2	O	Sled output ( + )
5	REB	O	Regulator base	19	DI3	I	Sled input
6	REO	O	Regulator output , 5V	20	LD CTL	I	Loading motor speed control
7	MUTE	I	Mute	21	Vcc1	-	Supply voltage 1
8	GND1	-	Ground 1	22	Vcc2	-	Supply voltage 2
9	DI5.1	I	Loading input 1	23	VREF	I	2.5V bias
10	DI2	I	Spindle input 2	24	DI4.1	I	Tracking input 1(Adjustable)
11	DO2.1	O	Spindle output ( + )	25	DI4.2	I	Tracking input 2
12	DO2.2	O	Spindle output ( - )	26	DO4.1	O	Tracking output 1 ( + )
13	GND2	-	Ground 2	27	DO4.2	O	Tracking output 2 ( - )
14	DI5.2	I	Loading input 2	28	GND3	-	Ground 3

## EQUIVALENT CIRCUITS

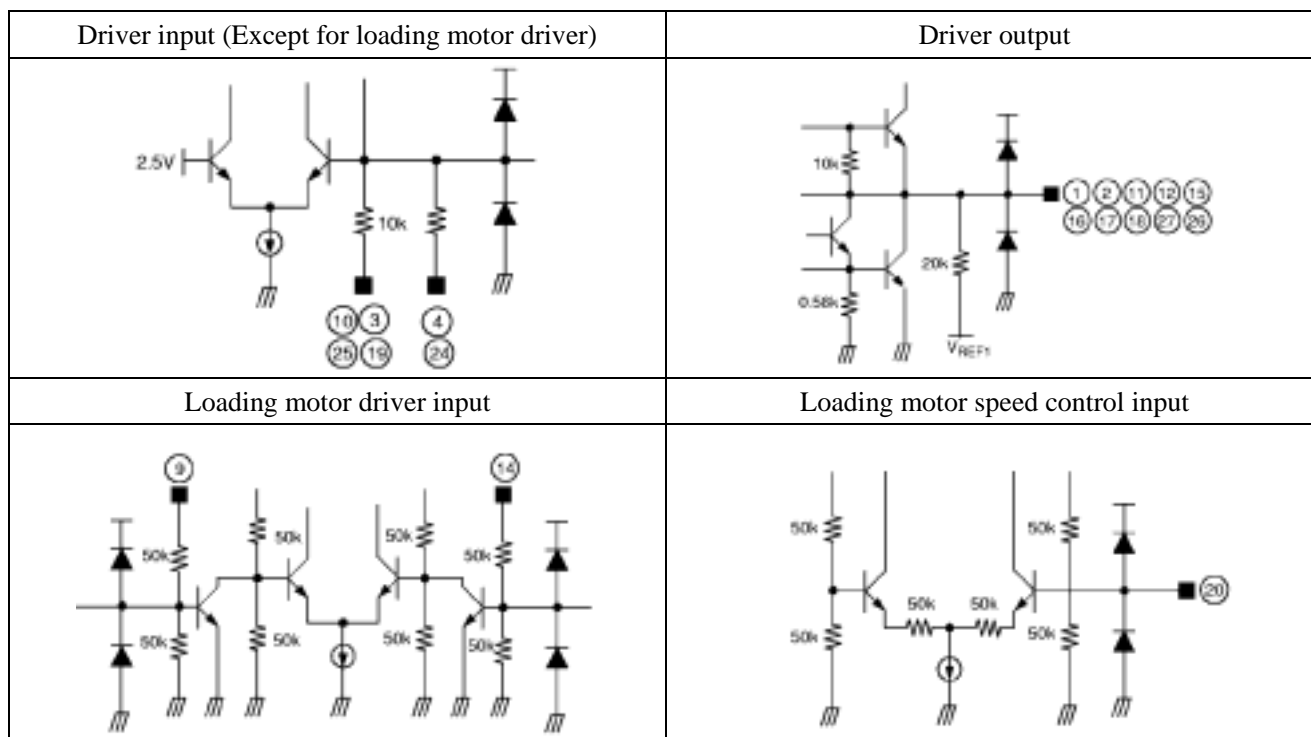

## EQUIVALENT CIRCUITS

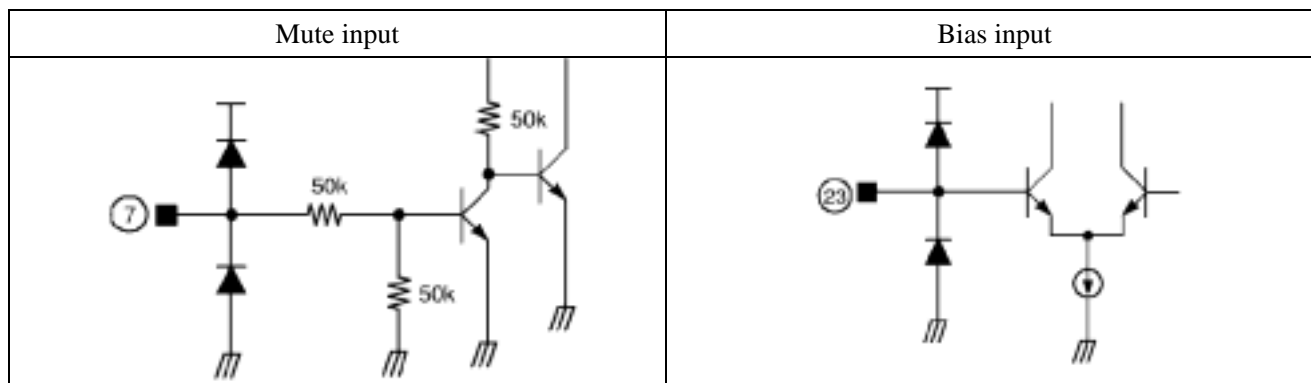

## ABSOLUTE MAXIMUM RATINGS (Ta=25°C)

Characteristic	Symbol	Value	Unit
Maximum Supply Voltage	V <sub>CCMAX</sub>	18	V
Maximum current output	I <sub>OMAX</sub>	1	A
Power dissipation	P <sub>D</sub>	1.7*	W
Operating temperature	T <sub>opr</sub>	-25~+75	
Storage temperature	T <sub>stg</sub>	-55~+150	

- \* NOTE: 1. When mounted on 76mm × 114mm × 1.57mm PCB (Phenolic resin material)  
 2. Power dissipation reduces 13.6mW/°C for using above Ta=25  
 3. Do not exceed Pd and SOA.

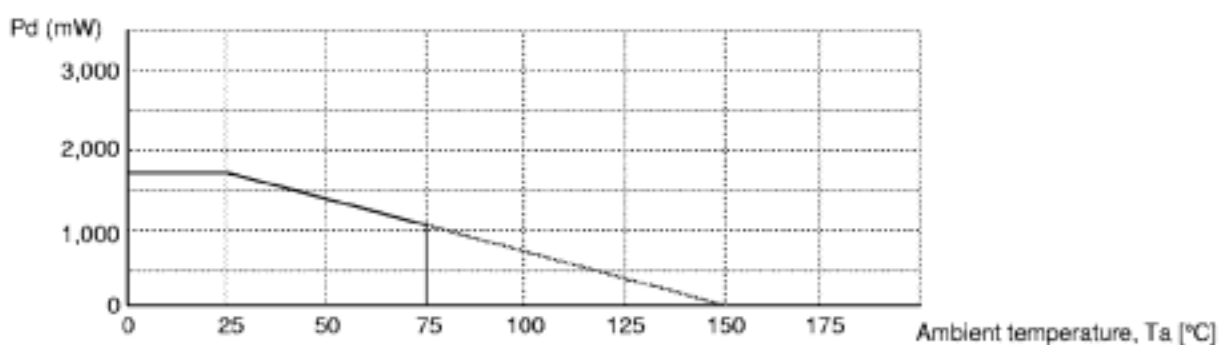

## RECOMMENDED OPERATING CONDITION (Ta=25°C)

Characteristics	Symbol	Value	Unit
Operating supply voltage	V <sub>cc</sub>	6~13.2	V

## ELECTRICAL CHARACTERISTICS

(Unless otherwise specified: Ta=25°C, Vcc=8V, f=1kHz, RL=8Ω)

Characteristic	Test conditions	Symbol	Min.	Typ.	Max.	Unit
Quiescent circuit current	Under no-load	ICCQ	7	10	13	mA
Mute-on current	Pin7=GND	IMUTE		4	7	mA
Mute-on voltage		VMON			0.5	V
Mute-off voltage		VMOFF	2			V
<b>Regulator Part</b>						
Output voltage	IL=100mA	VREG	4.7	5.0	5.3	V
Load regulation	IL=0→200mA	ΔVRL3	-50	0	50	mV
Line regulation	IL=100mA , Vcc=6→13V	ΔVcc	-20	0	80	mV
<b>Driver Part ( Except for loading motor driver )</b>						
Input offset voltage		VIO	-15.0		15.0	mV
Output offset voltage 1		VOO1	-40		40	mV
Maximum sink current 1	RL=8Ω→Vcc	ISINK	0.25	0.4		A
Maximum source current 1	RL=8Ω→GND	ISOURCE	0.25	0.4		A
Maximum output voltage 1	Vin=0.7V	VOM1	2.5	3.3		V
Maximum output voltage 2	Vin=7V	VOM2		-4.5	-3.7	V
Closed-loop voltage gain	Vin=0.1VRMS	AVF	5	6.5	8	dB
Ripple rejection ratio	Vin=0.1VRMS , f=120Hz	RR	40	60		dB
Slew rate	Vin=1VRMS , 120Hz , square wave	SR	1.0	2.0		V/μs
<b>Loading Motor Driver Part ( Unless otherwise specified : VCTL=opened )</b>						
Output voltage 1	RL=45Ω , VPIN9=5V , VPIN14=0V	VO1	2.5	3.1	3.8	V
Output voltage 2	RL=45Ω , VPIN9=0V , VPIN14=5V	VO2	2.5	3.1	3.8	V
Output voltage regulation 1 ( CTL )	RL=45Ω , VPIN9=5V , VPIN14=0V VCTL=3.5V→4.5V	VOCTL1	0.5	1.0	1.5	V
Output voltage regulation 2 ( CTL )	RL=45Ω , VPIN9=0V , VPIN14=5V VCTL=3.5V→4.5V	VOCTL2	0.5	1.0	1.5	V
Loading regulation 1	VPIN9=5V , VPIN14=0V , IL=100→400mA	ΔVRL1		300	700	mV
Loading regulation 2	VPIN9=0V , VPIN14=5V , IL=100→400mA	ΔVRL2		300	700	mV
Output offset voltage 2	VPIN9=5V , VPIN14=5V	VOO2	-40		40	mV
Output offset voltage 3	VPIN9=0V , VPIN14=0V	VOO3	-40		40	mV

## TEST CIRCUIT

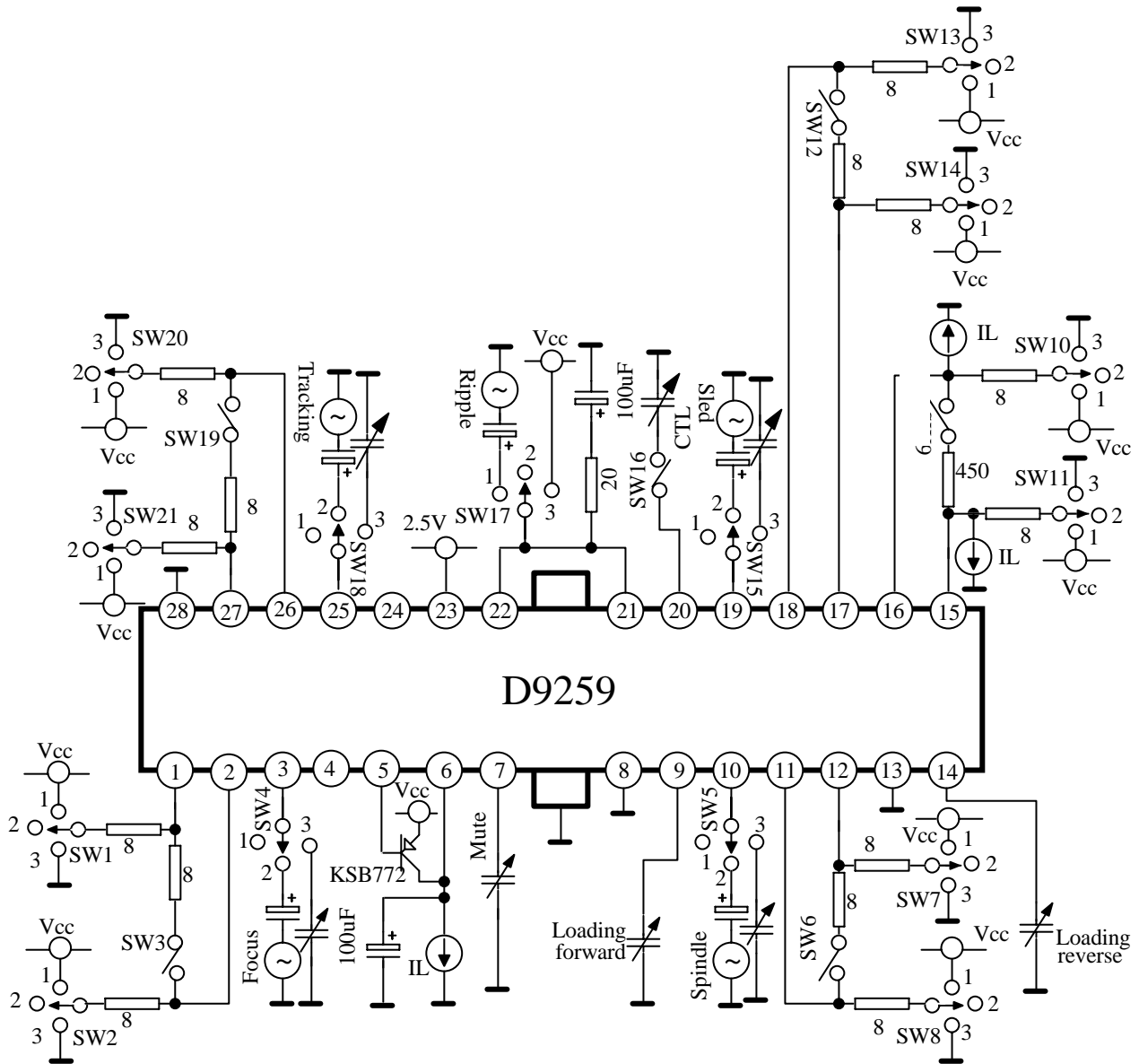

## APPLICATION CIRCUIT

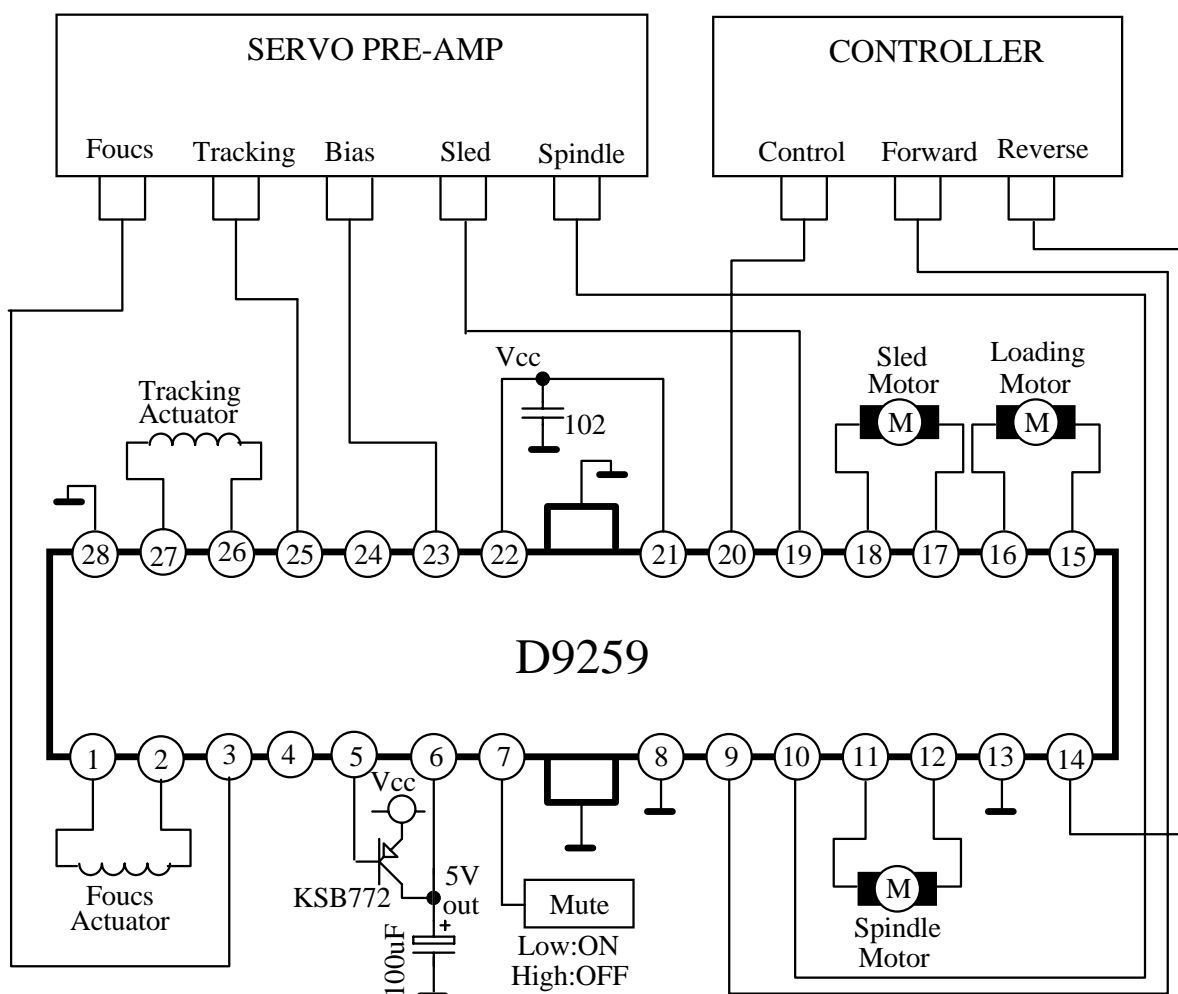

## APPLICATION INFORMATION

### 1. MUTE

Pin#7	Mute circuit
High	Turn-off
Low	Turn-on

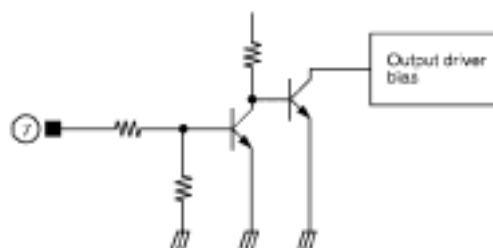

- When the mute pin#7 is open or the voltage of the mute pin#7 is below 0.5V, the mute circuit is activated so that the output circuit will be muted.
- When the voltage of the mute pin is above 2V, the mute circuit is stopped and the output circuit is operated normally.
- If the chip temperature rises above 175°C, then the TSD (Thermal shutdown) circuit is activated and the output circuit is muted.

**2. TSD (THERMAL SHUTDOWN)**

- The  $V_{REF\ BG}$  is the output voltage of the band-gap-referenced biasing circuit and acts as the input voltage of the TSD circuit.
- The base-emitter voltage of the TR, Q11 is designed to turn-on at below voltage.  $V_{BE} = V_{REF\ BG} \times R12 / (R11 + R12) = 400mV$ .
- When the chip temperature rises up to  $175^{\circ}C$ , then the turn-on voltage of the Q11 would drop down to 400mV. Hence, the Q11 would turn on so the output circuit will be muted.

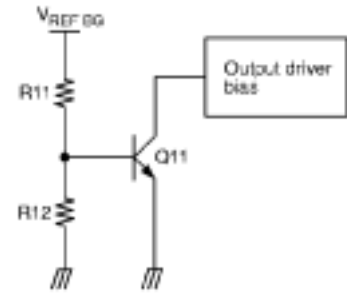

**3. REGULATOR**

- The  $V_{REF\ BG}$  is the output voltage of the band-gap-referenced biasing circuit and is the reference voltage of the regulator.
- The external circuit is composed of the transistor, KSB772 and a capacitor,  $100\mu F$ , and the capacitor is used as a ripple eliminator and should have a good temperature characteristics.
- The output voltage,  $V_{OUT}$  is decided as follows.

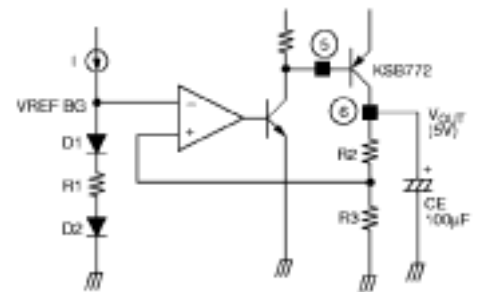

$$V_{OUT} = V_{REF\ BG} \times 2 = 2.5 \times 2 = 5V \quad (R2 = R3) \quad R2 = R3$$

**4. LOADING MOTOR DRIVER**

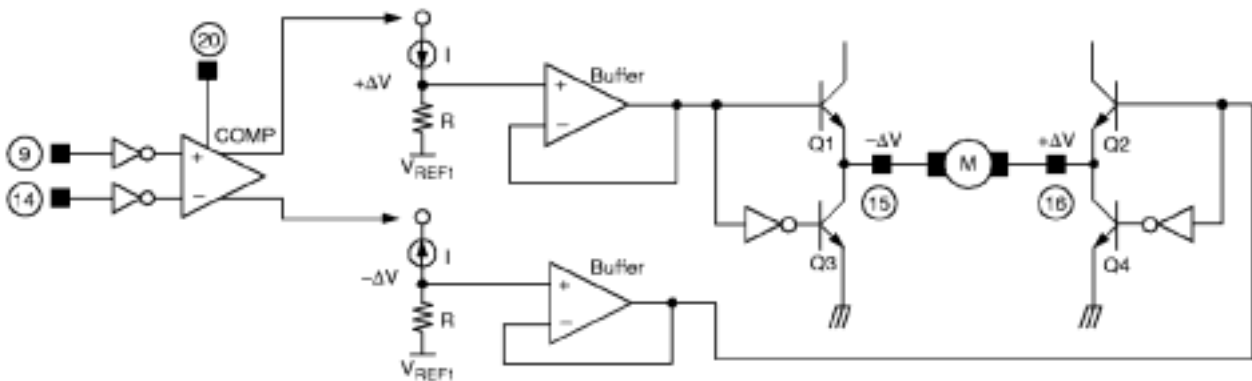

- The input voltage of (5V and 0V) or (0V and 5V) pairs are applied to the input pin#9 and #14 respectively.
- When the input voltage are applied to the input pin#9 and #14, then the output of the comparator is decided depends on the input voltage status.
- As shown in the above diagram, the difference  $\Delta V$ ,  $[V_{REF1} + (I \times R)] - [V_{REF1} - (I \times R)]$ , is applied to the both terminals of the motor. The direction of the motor is decided by the voltage difference,  $+\Delta V$  and  $-\Delta V$ .

- The output characteristics is as follows,
  - If pin#9=5V and pin#14=0V, then pin#15=+ΔV and pin#16=-ΔV, hence the motor turn in forward direction.
  - If pin#9=0V and pin#14=5V, then pin#15=-ΔV and pin#16=+ΔV, hence the motor turn in reverse direction.
  - If pin#9=5V and pin#14=5V, then ΔV =0V, hence the motor stop.
  - If pin#9=0V and pin#14=0V, then ΔV =0V, hence the motor stop.
- When the rotation speed control of the loading motor is desired, refer to the follows.

## 5. LOADING MOTOR SPEED CONTROL

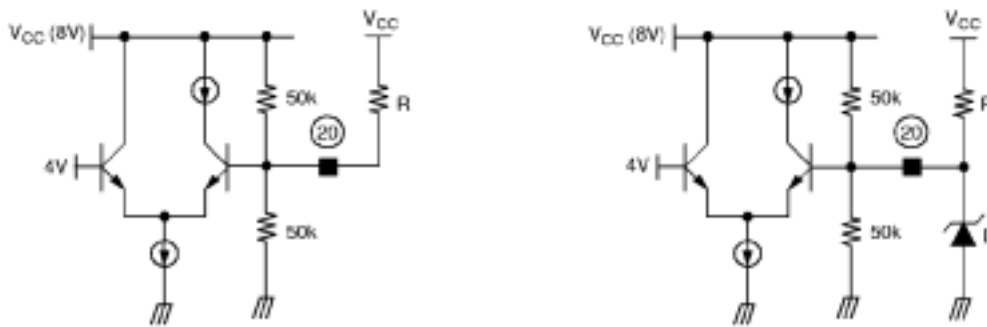

- If the torque of the loading motor is too low when it is used with the pin#20 open, then it should used as the above diagram.
- The desired torque could be obtained by selecting the appropriate resistor R as shown in the left diagram.
- If it is necessary, the zener diode can be used as in the right diagram.
- The maximum torque is obtained when the applied voltage at pin#20 is about 6.8V (at Vcc=8V).

## 6. DRIVER (EXCEPT FOR LOADING MOTOR DRIVER)

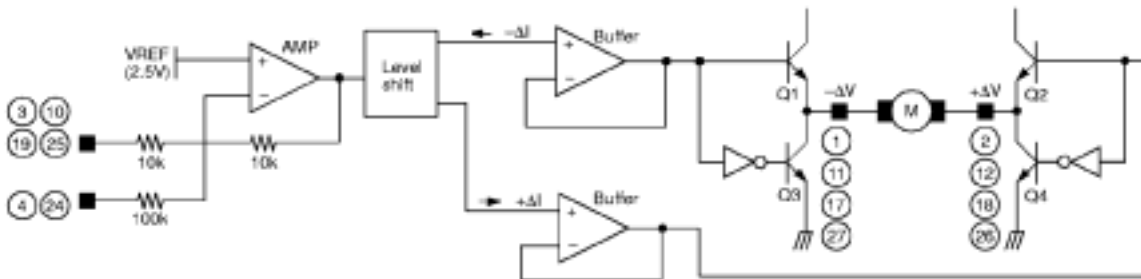

- The voltage,  $V_{REF}$ , is the reference voltage given by the bias voltage of the pin#23.
- The input signal through the pin#3 is amplified by 10k/10k times and then fed to the level shift.
- The level shift produces the current due to the difference between the input signal and the arbitrary reference signal. The current produced as  $+\Delta I$  and  $-\Delta I$  is fed into the driver buffer.
- Driver Buffer operates the power TR of the output stage according to the state of the input signal.



- The output stage is the BTL Driver and the motor is rotating in forward direction by operating TR Q1 and TR Q4. On the other hand ,if TR Q2 and TR Q3 is operating, the motor is rotating in reverse direction.
- When the input voltage through the pin#3 is below the  $V_{REF}$ , then the direction of the motor in forward direction.
- When the input voltage through the pin#3 is above the  $V_{REF}$ , then the direction of the motor in reverse direction.
- If it is desired to change the gain, then the pin#4 or pin#24 can be used.

7. When the bias voltage of the pin#23 is below 1.4V, then the output circuit will be muted. Hence for the normal operation, the bias voltage should be used in 1.6V~6.5V

8. Connect a by-pass capacitor, 0.1 $\mu$ F between the supply voltage source.

9. Radiation fin is connecting to the internal GND of the package.  
Connect the fin to the external GND.

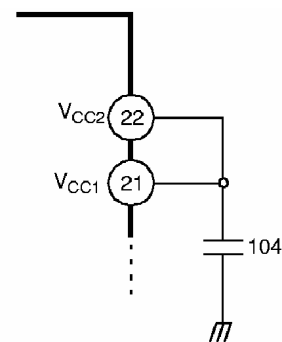

## ELECTRICAL CHARACTERISTICS CURVES

Vcc vs. Icc

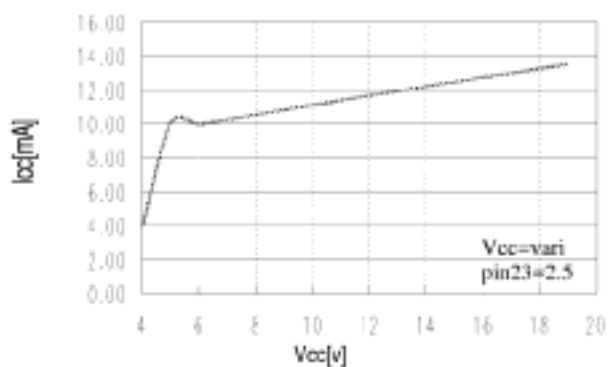

Vcc vs. Imute

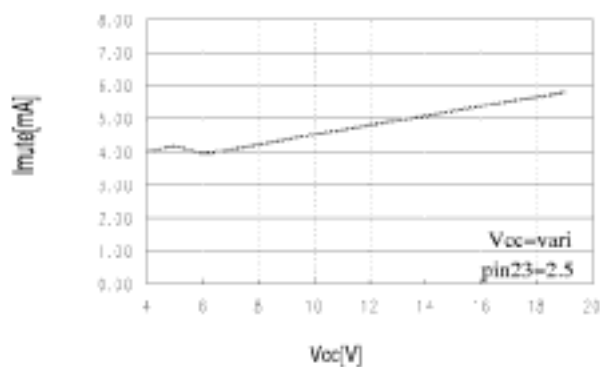

Vcc vs. Isink

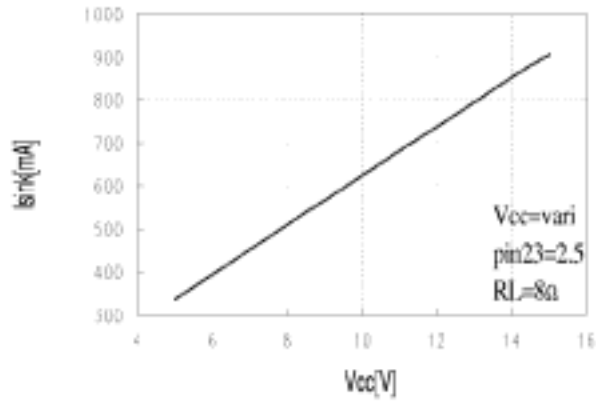

Vcc vs. Avf

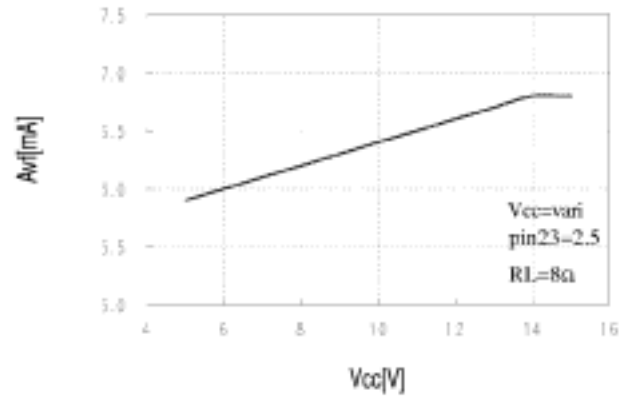

Vcc vs. Vom

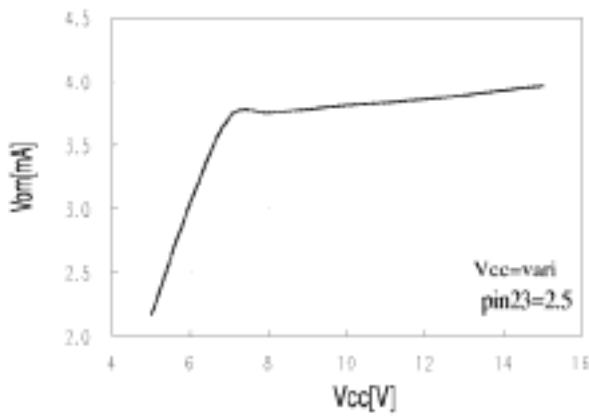

Vcc vs. Vreg

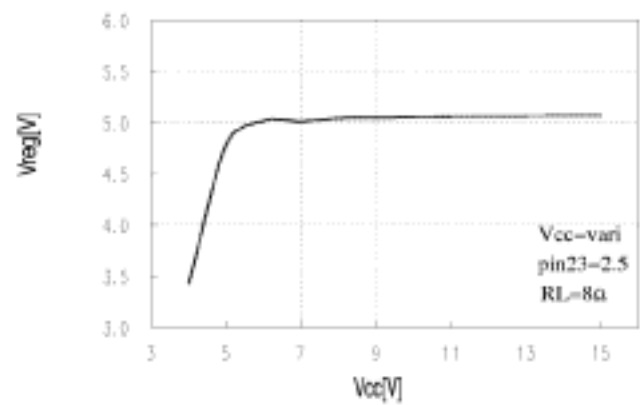

Frequency vs. Avf

