

## ▶ Product Introduction

### Token (DA) Dielectric Patch Antenna Technology Makes The List.

#### Features :

- Small patch dimensions.
- Using high quality factor.
- Stabilized temperature coefficient.
- Provide highly stabilized performance.

#### Applications :

- Global Positioning Systems (GPS)
- GPS Hold, Car Navigation System, GPS PDA.
- W-LAN.

Dielectric antenna is fed using coaxial ceramic media. By a coaxial extension of the inner conductor to form an oscillator, used to excitation of electromagnetic waves, the sleeve of the role of the media, except clamping bar, the more important is the reflection of electromagnetic waves, thus ensuring the incentives from the coaxial line inner conductor of electromagnetic waves to the free end of dielectric rod transmission.

Token use of low-loss dielectric antennas, high-frequency dielectric material, strict process control, apply to the Global Positioning System (GPS), radio broadcast system of small antenna elements.

Token electronics manufacturing dielectric patch antenna with rectangular micro strip antenna design and offset one point feeding method for Global Positioning System GPS, media filters, multi-layer filters, cavity filters, band-pass filter, military filters, high-frequency filters and so on, in line with RoHS standards.

(DA) series of microwave antenna, which provides clients a custom design and deliver smaller tolerances. Dielectric antenna application specific design, but also for the frequency requirements, including different inductance values and Q specifications adjusted.

Token will also produce devices outside these specifications to meet specific customer requirements, contact us with your specific needs. For more information, please link to Token official website "[Dielectric resonators](http://www.token.com.tw)".



## Typical Specifications

### Typical Specifications (DA)

Part Number	Size (mm)	Center Frequency (MHz)	Band width (MHz)	Gain (dBi)	Ground Plane (mm)	Application
DA1575S25T4A	25*25*4	1575	≥10	4.5	35*35	GPS
DA1575S25T4B	25*25*4	1575	≥10	4.5	70*70	
DA1575S25T2B	25*25*2	1575	≥10	4.5	70*70	
DA1580S25T4A	25*25*4	1580	≥15	4.5	35*35	
DA1580S25T4B	25*25*4	1580	≥15	4.5	70*70	
DA1580S25T2B	25*25*2	1580	≥15	4.5	70*70	
DA1580S18T4	18*18*4	1580	≥10	3.0	50*50	
DA1580S18T2	18*18*2	1580	≥10	3.0	50*50	
DA1580S13T4	13*13*4	1580	≥5	0.0	50*50	
DA2450S13T4	13*13*4	2450	≥5	0.0	50*50	
DA2450S13T2	13*13*2	2450	≥5	0.0	50*50	
DA1575S36T4	36*36*4	1575	≥30	5.0	80*80	
DA2450D16	Φ16	2450	45	2.1	50*70	
DA1616S25(Tx)	25*25*4	1616	≥10	4.0	70*70	Beidou Satellite Position System
DA2492S25(Rx)	25*25*4	2492	≥10	4.0	70*70	

● Note: Customer's specification, custom design, or ODM are welcomed on request.

## Dimensions

### Dimensions (DA)

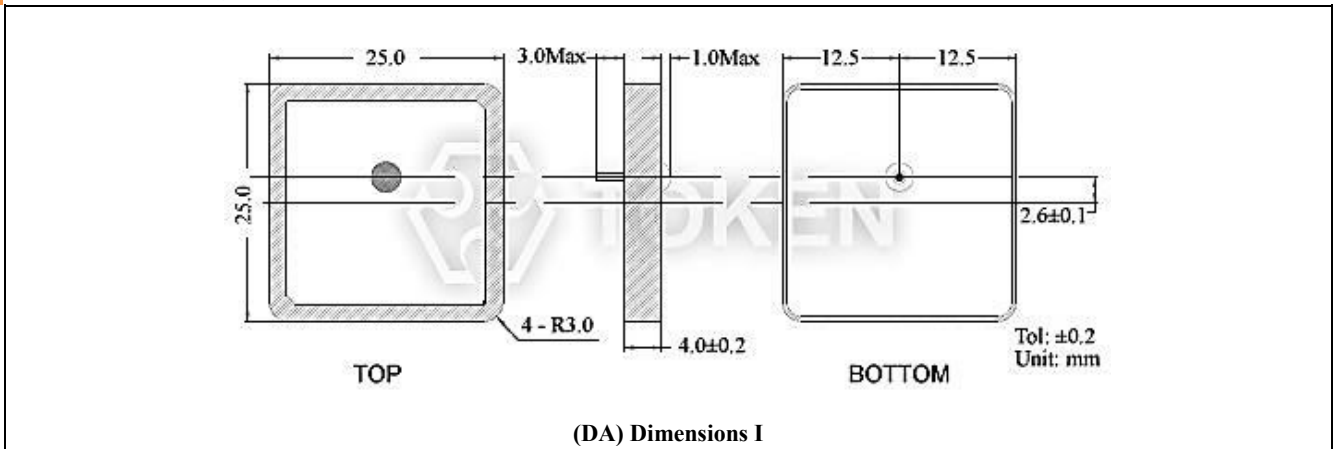

(DA) Dimensions I

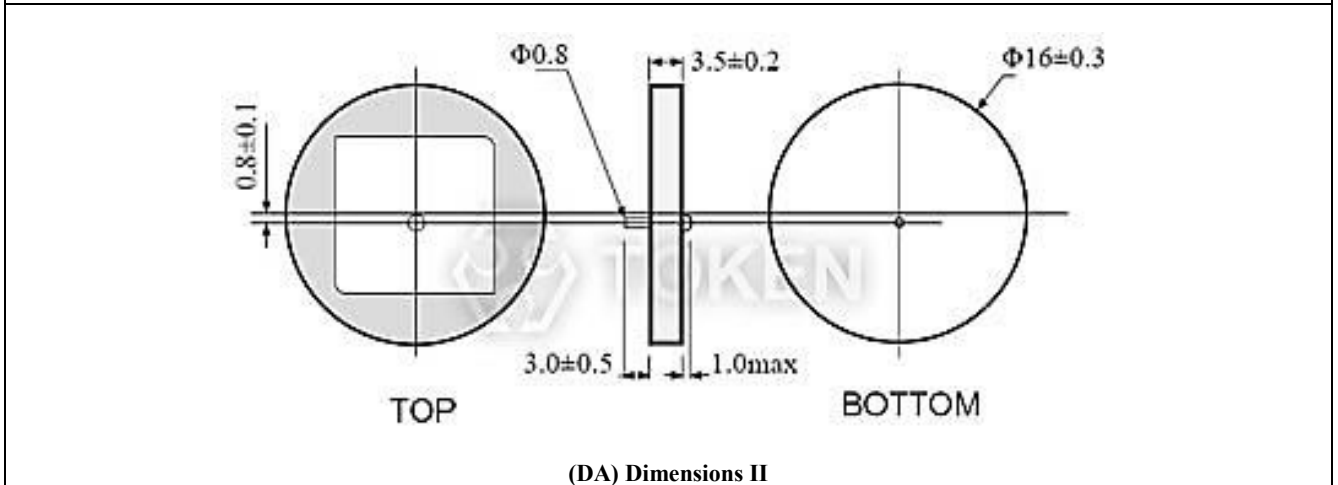

(DA) Dimensions II

## Typical Characteristic

### Typical Characteristic (DA)

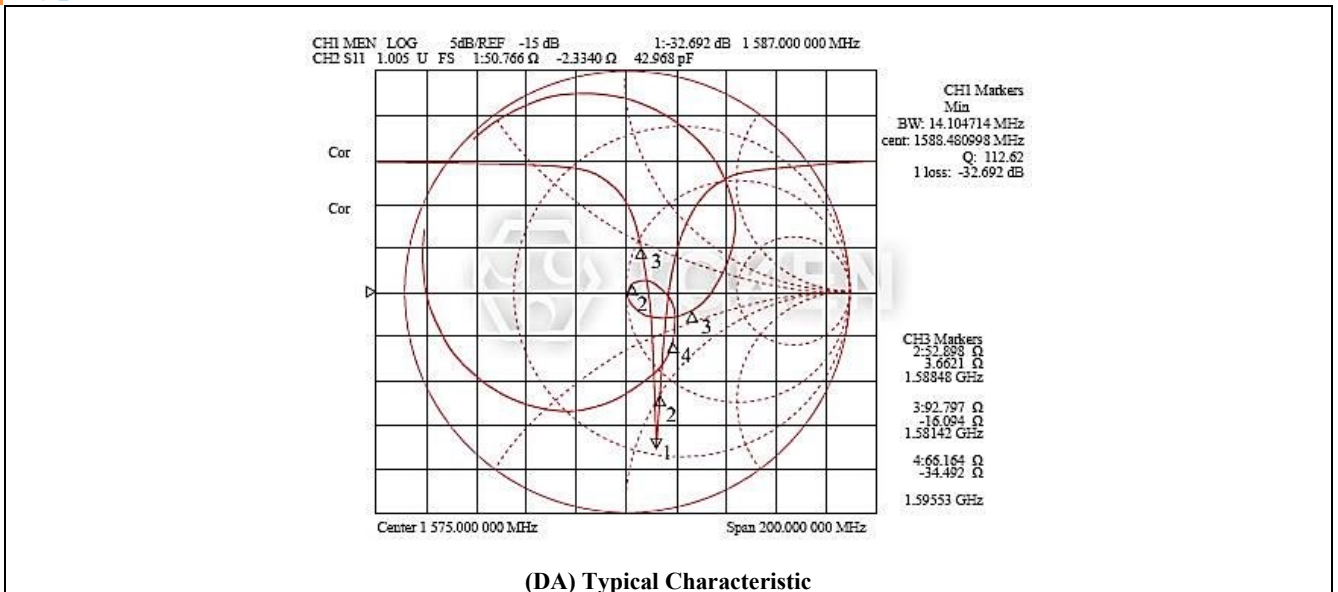

## Order Codes

### Order Codes (DA)

DA	1580	S	18	T2
Dielectric Patch Antenna	Center Frequency	Structure	Dimensions	Thickness

## ▶ General Information

### Advantage of Token's Microwave Dielectric Components

New Microwave Dielectric Materials for Wireless Communication from Token Electronics

"Everything from the electromagnetic properties to microstructure of the material is important for the final result"

A small ceramic component made from a dielectric material is fundamental to the operation of filters and oscillators in several microwave systems, such as satellite TV receivers, military radar systems, Global Positioning System (GPS) devices, and mobile communications. Token Electronics had been able to develop specialized piezoelectric materials which lead to more reliable and clearer microwave communication signals.

In microwave communications, dielectric components are used to discriminate between wanted and unwanted signal frequencies in the transmitted and received signal. When the wanted frequency is extracted and detected it is necessary to maintain a strong signal nevertheless. For clarity it is also critical that the wanted signal frequencies are not affected by seasonal temperature changes.

The resonator materials for practical applications have to have certain key properties. A high relative dielectric constant is needed so that the materials can be miniaturized and a high quality factor (Q) is needed for improved selectivity. Low temperature variation of the material's resonant frequency is also required so that the microwave circuits remain stable.

Although large numbers of ceramic dielectric materials have been developed, it has proven difficult to satisfy all these requirements in a single material at a reasonable cost. "Token takes the advantages of these new materials that they are relatively cheap compared with some of the compounds currently used and in the future they can be improved even further by suitable additives and by optimizing the preparation conditions."

### Dielectric Material Composition & Study

The new dielectric materials developed by Token, are based on ceramics formed by baking the pressed powdered starting material mixture in a furnace at between 1200 and 1550 degrees Celsius.

Token Engineers used X-ray diffraction studies, Raman spectroscopy and scanning electron microscopy to reveal the structure of the ceramics. The materials have the general formula  $Ce(M_{1/2}Ti_{1/2})O_{3.5}$ . Ce is the element cerium, Ti is titanium and O is oxygen. "M" represents any one of the metals magnesium, zinc, calcium, cobalt, manganese, nickel or tungsten. The numbers refer to the proportions of each element in the ceramic.

"Further work is in progress to find the exact composition, internal structure and secondary phases in the ceramics".

### Token's Service & PDF Catalogue Download

Token reliably deliver high-quality microwave dielectric components according to the each customer special needs with respect to performance, costs, and technology modifications.

For marketing discontinuations or sourcing activities concerning dielectric products, you are encouraged to contact our Sales Department so the request can be properly directed within Token.

