

FEATURES

- 10-bit Resolution
- Single +5V Operation
- TTL CMOS
- 80MHz Conversion Rate
- Low 150mW Power Dissipation
- Low Glitch Energy, 50pV/s
- Built-in Independent Constant-Voltage Source

OBSOLETE PRODUCT

Contact Factory for Replacement Model

GENERAL DESCRIPTION

The DAC-341 is a single channel 10-bit, 80MHz Digital to Analog Converter designed for video applications. The DAC-341's main features include ± 0.5 LSB differential nonlinearity, single +5V power supply operation, a built-in constant voltage reference and very low glitch energy.

The DAC-341 develops a full scale output current of 10mA or 2.0V with 200 Ω shunt resistor. An internal voltage reference source may be used to provide stable output independent of power supply fluctuations. Input coding is straight binary.

The DAC-341 is a low power device requiring only 30mA max. of +5V power supply current.

The DAC-341 is packaged in a 32-pin plastic QFP and operates over a -20°C to +70°C temperature range.

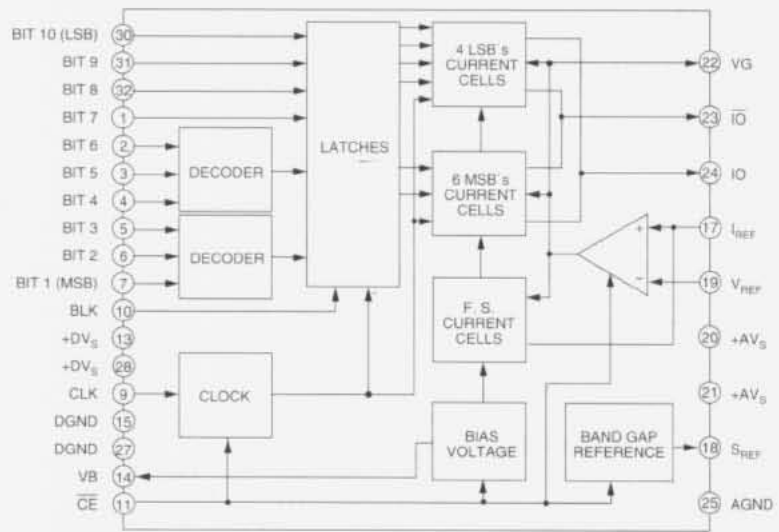

Figure 1: DAC-341 Functional Block Diagram

INPUT/OUTPUT CONNECTIONS

PIN	FUNCTION	PIN	FUNCTION
1	BIT 7	17	I_{REF}
2	BIT 6	18	S_{REF}
3	BIT 5	19	V_{REF}
4	BIT 4	20	+AV _S (Analog)
5	BIT 3	21	+AV _S (Analog)
6	BIT 2	22	VG
7	BIT 1 (MSB)	23	$\bar{I}O$
8	NO CONNECTION	24	IO
9	CLK	25	AGND
10	BLK	26	NO CONNECTION
11	CE	27	DGND
12	NO CONNECTION	28	+DV _S (Digital)
13	+DV _S (Digital)	29	NO CONNECTION
14	VB	30	BIT 10 (LSB)
15	DGND	31	BIT 9
16	NO CONNECTION	32	BIT 8

Mechanical Dimensions

Units: mm

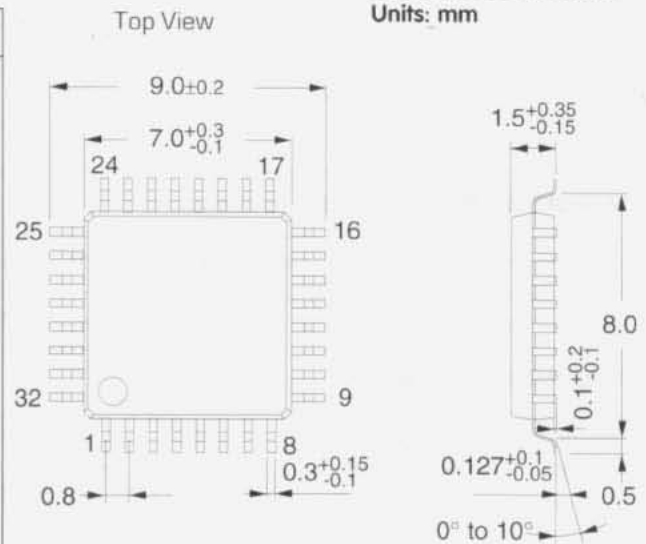

ABSOLUTE MAXIMUM RATINGS (Ta = 25°C)

PARAMETERS	SYMBOLS	LIMITS	UNITS
Supply Voltage	(+AV _S , +DV _S)	7	V
Input Voltage		-0.5 to +V _S	V
Output Current		0 to 15	mA

ELECTRICAL CHARACTERISTICS

(Typical at Ta = 25°C, +AV_S = +DV_S = +5V, V_{REF} = 2.0V, R = 200Ω, 16R = 3.3kΩ and F_S = 80MHz unless otherwise specified)

PARAMETERS	SYMBOLS	MIN.	TYP.	MAX.	UNITS
------------	---------	------	------	------	-------

INPUTS

Digital Input Voltage	1(V _{IH}) 0(V _{IL})	2.15	-	-	V
Digital Input Current	1(I _{IH}) 0(I _{IL})	-	-	5	μA
Setup Time	(T _S)	5.0	-	-	ns
Hold Time	(T _H)	1.0	-	-	ns
Clock Pulse Width	(T _{PW1} /T _{PW0})	6.25	-	-	ns
Voltage Reference	(V _{REF})	1.9	2.0	2.1	V

OUTPUTS

Accuracy guaranteed Output					
Voltage Range	(V _{OC})	1.8	1.92	2.0	V
Full Scale Output Voltage	(V _{FS})	1.8	1.92	2.0	V
Full Scale Output Current	(I _{FS})	9.0	9.6	10	mA
S _{REF} Output Voltage	(S _{REF})	1.0	-	1.3	V

PERFORMANCE

Resolution		-	10	-	Bits
Conversion Rate	(F _S)	80	-	-	MHz
Integral Linearity Error	(I _{NL})	-2.0	-	2.0	LSB
Differential Linearity Error	(D _{NL})	-0.5	-	0.5	LSB
Output Offset Voltage	(V _{OS})	-	-	1	mV
Propagation Delay Time	(T _D)	-	10	-	ns
Glitch Energy	(@1V _{pp} F.S.)	-	50	-	pV/s
Differential Gain		-	2.5	-	%
Differential Phase		-	1.3	-	deg

POWER SUPPLY REQUIREMENTS

Supply Voltage	(+AV _S , +DV _S)	4.75	5.0	5.25	V
Supply Current	(I _S)	-	-	30	mA
Power Dissipation	(P _D)	-	-	150	mW

ENVIRONMENTAL/PHYSICAL

Operating Temperature Range		-20	-	+70	°C
Storage Temperature Range	-55	-	+150	-	°C
Package		32-Pin Plastic QFP			
Weight		0.2			g

Technical Notes

1. Separate the analog and digital signals around the device to reduce noise effects. Bypass the +AV_S and +DV_S terminals to the respective GNDs with a 0.1 μF ceramics capacitor placed as close to the pin as possible.

2. The DAC-341 is a current output D/A converter. To generate an output voltage, connect a 200Ω resistor to the current output terminal (Pin 24). See Typical Connections or calculate the output resistance from V_{FS} = I_{FS} × R1. Connect a resistance (R2) sixteen times the output resistance (R1) to the reference current terminal I_{REF} (Pin 17). Note also that V_{FS} = V_{REF} × 16R1/R2, and when connected directly to S_{REF}, V_{FS} = S_{REF} × 16R1/R2. Power consumption can be reduced by increasing the resistance, but this will also increase the glitch energy and output settling time. Choose the best values according to the application.

3. The S_{REF} is an independent regulated voltage source. By connecting it to the V_{REF} (Pin 19) a stable output, independent of power supply fluctuations, can be obtained. Note that connecting S_{REF} to V_{REF} changes the value of R2.

4. For the DAC-341 to provide the specified performance the data transmitted from outside and the clock must be synchronized properly. Adjust the setup time (T_S) and hold time (T_H) as specified.

5. The +AV_S and +DV_S Pins must use the same power supply. This is required to prevent latch up that may be caused by a potential difference between the two terminals when the power is turned on.

Table 1. Coding Table

Input Code	Output Voltage (2V FS)
MSB	LSB
000000000	0V
000000001	0.002V
⋮	⋮
100000000	1.000V
⋮	⋮
110000000	1.500V
⋮	⋮
111111111	1.998V

Timing Diagram

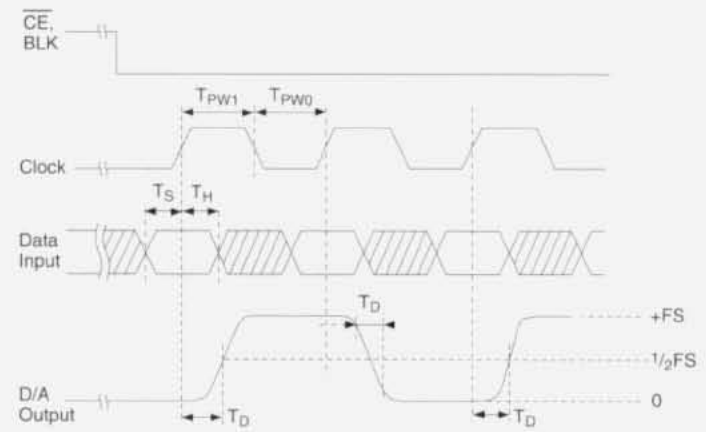
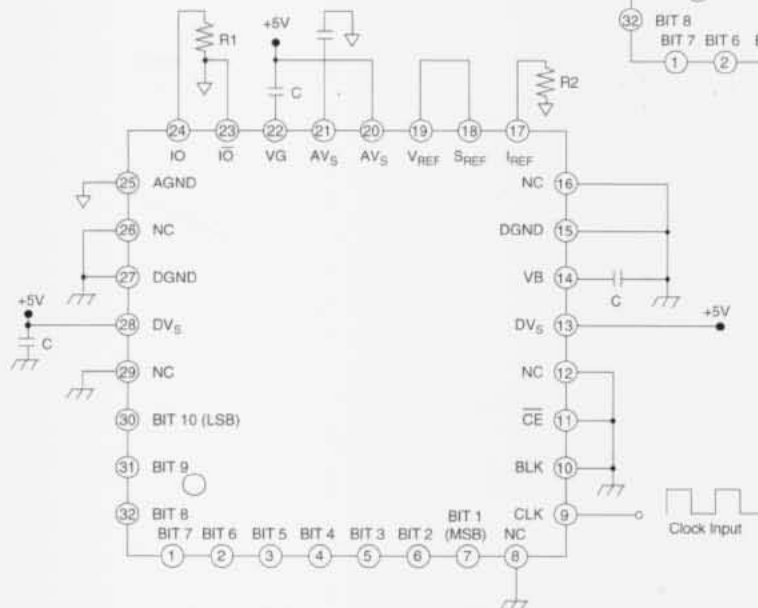
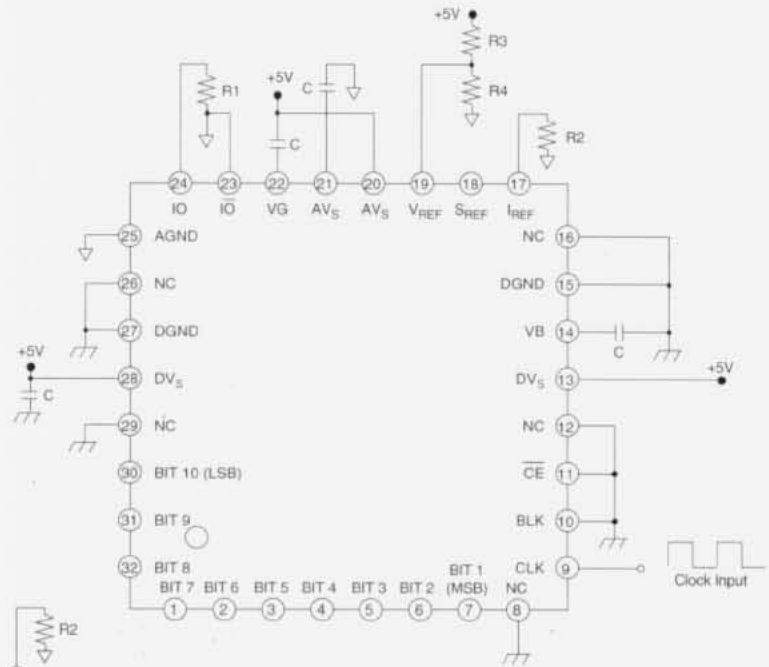

Figure 2. Typical Connection Diagrams

- 5.0V supply voltage (DV_5 and AV_5)
- Digital input from Pins 30 to 32 and Pins 1 to 7
- Pin 18 is left open
- $R1 = 200\Omega$
- $R2 = 3.3k\Omega$
- $R3 = 3.0k\Omega$
- $R4 = 2.0k\Omega$
- $C = 0.1\mu F$



- 5.0V supply voltage (DV_5 and AV_5)
- Digital input from Pins 30 to 32 and Pins 1 to 7
- $R1 = 200\Omega$
- $R2 = 2.0k\Omega$
- $C = 0.1\mu F$

Equivalent Circuits

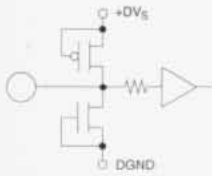

Digital input, BLK, \overline{CE} and CLK inputs

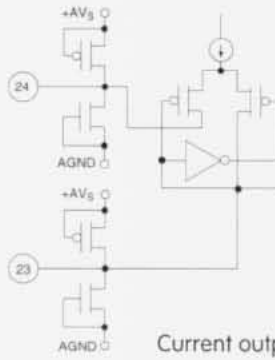

Current output pins

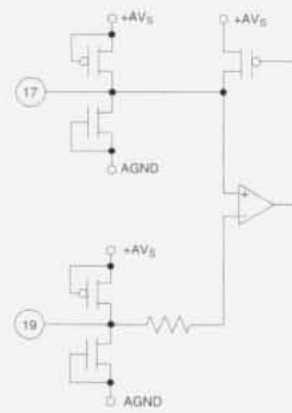

Reference Pins (V_{REF} , I_{REF} , VG)

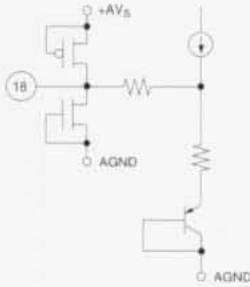

Constant Voltage output

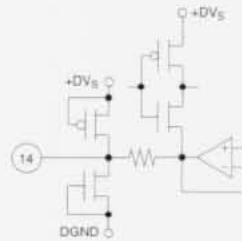

Bias Voltage

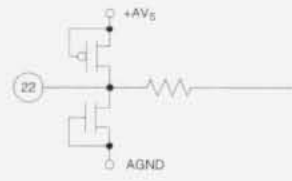

Typical Performance Curves

Output fullscale voltage vs. reference voltage

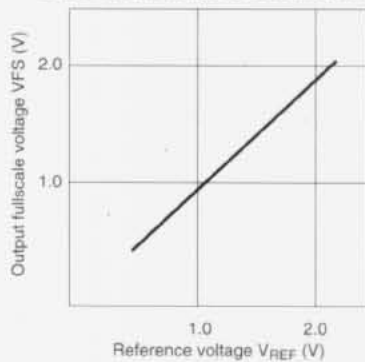

Output resistance vs. Glitch energy

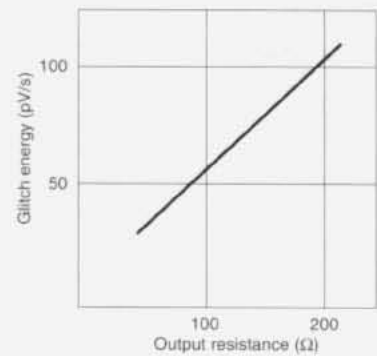

Output fullscale voltage vs. T_a

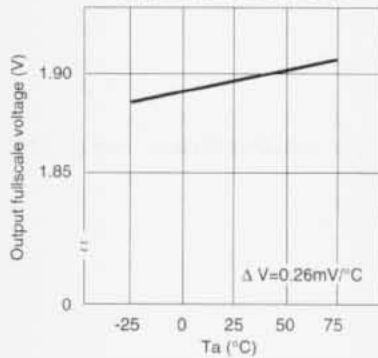

Output frequency vs. current consumption

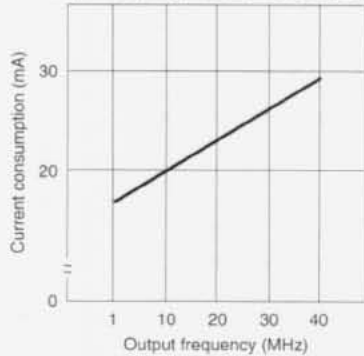

S_{REF} vs. T_a

