

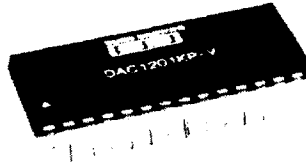

# DAC1201KP-V



## Monolithic Microprocessor-Compatible 12-Bit Resolution DIGITAL-TO-ANALOG CONVERTER

### FEATURES

- COMPLETE D/A CONVERTER:  
INTERNAL REFERENCE  
 $\pm 10V$  OUTPUT OPERATIONAL AMPLIFIER
- MICROPROCESSOR INTERFACE LOGIC FOR A 4-, 8-,  
12- OR 16-BIT BUS
- MONOTONICITY GUARANTEED  $0^{\circ}C$  to  $+70^{\circ}C$
- SETTLING TIME  $7\mu s$ , MAX
- $\pm 12V$  to  $\pm 15V$  POWER SUPPLY OPERATION
- 28-PIN MOLDED PLASTIC DIP
- LOWEST COST BUFFERED 12-BIT DAC

### DESCRIPTION

The low price of DAC1201KP makes this 12-bit resolution D/A converter the best value available for commercial applications requiring a microprocessor interface.

The DAC1201 features microprocessor interface logic, TTL input compatibility, guaranteed monotonicity over  $0^{\circ}C$  to  $+70^{\circ}C$  and settling time of  $7\mu s$  maximum.

The interface logic is partitioned in 4-bit nibbles permitting 4-, 8-, 12- and 16-bit bus interface connections for right- or left-justified input words. Dual rank latches permit flexible timing operations for microprocessor control of the DAC1201.

This precision component is made possible using Burr-Brown's proprietary monolithic integrated circuit process which has been optimized for converter circuits. A stable subsurface reference zener, laser-trimmed thin-film ladder resistors, and high speed current switches combine to give superior performance over the rated temperature range.

DAC1201 is priced and specified for applications where high resolution and monotonicity are the key application parameters and where tightly specified performance over temperature is not required. Because of the low price, it is feasible to use this 12-bit D/A converter for new applications in communications systems, electronic controllers, medical instrumentation, electronic games and personal computer peripherals.

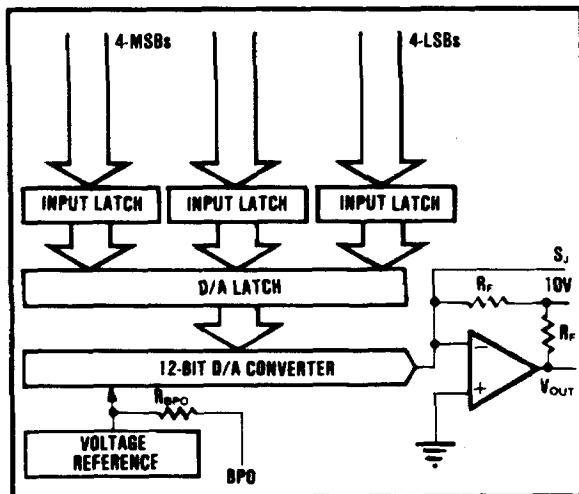

International Airport Industrial Park - P.O. Box 11400 - Tucson, Arizona 85734 - Tel. (602) 746-1111 - Twx: 910-952-1111 - Cable: BBRCORP - Telex: 66-6491

PDS-621B

# SPECIFICATIONS

## ELECTRICAL

Typical at +25°C and  $\pm V_{CC} = 12V$  or  $15V$ ,  $V_{DD} = +5V$  unless otherwise noted.

MODEL	DAC1201KP-V	UNITS
<b>INPUTS</b>		
<b>DIGITAL INPUTS</b>		
Input Code <sup>(1)</sup>	USB, BOB	
Resolution	12	Bits
Digital Logic Inputs <sup>(2)</sup>		
$V_{IH}$ , min to max	+2.4 to $+V_{CC}$	V
$V_{IL}$ , min to max	0 to +0.8	V
$I_{IH}$ , $V_i = +2.7V$ , max	+20	$\mu A$
$I_{IL}$ , $V_i = +0.4V$ , max	$\pm 30$	$\mu A$
<b>TRANSFER CHARACTERISTICS</b>		
<b>ACCURACY</b>		
Linearity Error, max <sup>(3)</sup>	$\pm 0.018$	% of FSR <sup>(4)</sup>
Differential Linearity Error, max	$\pm 0.024$	% of FSR
Gain Error, max <sup>(5)(6)</sup>	$\pm 0.3$	%
Unipolar Offset Error <sup>(5)(7)</sup>	$\pm 20$	mV
Bipolar Offset Error, max <sup>(5)(8)</sup>	$\pm 40$	mV
Monotonicity Over 0°C to +70°C <sup>(9)</sup>	12	Bits
Sensitivity of Gain to Power Supply Variations:		
+ $V_{CC}$ and - $V_{CC}$	$\pm 0.002$	% of FSR/ $\%V_{CC}$
$V_{DD}$	$\pm 0.006$	% of FSR/ $\%V_{DD}$
<b>TEMPERATURE COEFFICIENTS</b>		
Gain	$\pm 10$	ppm/°C
Bipolar Zero <sup>(10)</sup>	$\pm 6$	ppm of FSR/°C
<b>SETTLING TIME</b> (to $\pm 0.012\%$ of FSR) <sup>(11)</sup>		
20V step and 2k $\Omega$ load, max	7	$\mu s$
<b>OUTPUT</b>		
<b>ANALOG OUTPUT</b>		
Voltage Range, min <sup>(12)</sup>	$\pm 5, \pm 10, +10$	V
Current, min <sup>(13)</sup>	$\pm 5$	mA
Impedance	0.2	$\Omega$
<b>REFERENCE OUTPUT</b>		
Voltage <sup>(14)</sup>	+6.3	V
Source Current Available for External Loads, max	+1.5	mA
Temperature Coefficient	$\pm 10$	ppm/°C
<b>POWER SUPPLY REQUIREMENTS</b>		
<b>RATED VOLTAGE</b>		
+ $V_{CC}$ /- $V_{CC}$ <sup>(15)(16)</sup>	+15/-15	V
$V_{DD}$ <sup>(17)</sup>	+5	V
<b>CURRENT</b> (no load), max <sup>(18)</sup>		
+ $V_{CC}$ /- $V_{CC}$	+25/-35	mA
$V_{DD}$	+15	mA
<b>TEMPERATURE RANGE</b>		
For parameters specified over temp, min to max	0 to +70	°C
Storage, min to max	-60 to +100	°C

NOTES: (1) USB = Unipolar Straight Binary, BOB = Bipolar Offset Binary. (2) Digital inputs are TTL-compatible for  $V_{DD}$  over the range of +4.5V to 5.5V. Digital input specs are guaranteed over 0°C to +70°C. The specs are tested at 25°C only. (3)  $\pm 0.018\%$  of FSR is 3/4LSB for 12 bits. (4) FSR means Full-Scale Range and is 20V for a  $\pm 10V$  range. (5) Adjustable to zero with external potentiometer. (6) Adjusting the Gain Adjust potentiometer rotates the transfer function about 0V for unipolar operation and about minus full scale (-FS) for bipolar operation. (7) Error at input code 000<sub>w</sub> for unipolar operation (output at 0V). (8) Error at input code 000<sub>w</sub> for bipolar operation (output at minus full scale, -FS). (9) Guaranteed. Tested at 25°C only. (10) Drift at 0V output for bipolar operation (input code 100<sub>w</sub>). (11) Guaranteed. Not tested. (12) Minimum supply voltage required for  $\pm 10V$  output swing  $\pm 13.5V$ . Output swing for  $\pm 11.4V$  supplies is at least -8V to +8V. (13) Output may be indefinitely shorted to Common without damage. (14) Tolerance is  $\pm 5\%$ . (15) The maximum voltage separation between ACOM and DCOM without affecting accuracy is  $\pm 0.5V$ . (16) Range

of operation is  $\pm 11.4V$  to  $\pm 16.5V$ . (17) Range of operation is +4.5V to +5.5V. (18) Typical power supply currents are approximately 70% of the maximum.

## ABSOLUTE MAXIMUM RATINGS

+ $V_{CC}$ to ACOM	0 to +18V
- $V_{CC}$ to ACOM	0 to -18V
$V_{DD}$ to DCOM	0 to +7V
$V_{DD}$ to ACOM	$\pm 7V$
ACOM to DCOM	$\pm 7V$
Digital Inputs (pins 2-14, 16-19) to DCOM	-0.4V to +18V
External Voltage Applied to 10V Range Resistor	$\pm 12V$
REF OUT	Indefinite short to ACOM
External Voltage Applied to Analog Output	-5V to +5V
Power Dissipation	1000mW
Operating Temperature	0°C to +70°C
Storage Temperature	-60°C to +100°C

NOTE: Stresses above those listed under "Absolute Maximum Ratings" may cause permanent damage to the device. Exposure to absolute maximum conditions for extended periods may affect device reliability.

## MECHANICAL

DIM	INCHES		MILLIMETERS	
	MIN	MAX	MIN	MAX
A	1.400	1.460	35.56	37.08
B	.530	.575	13.46	13.67
C	.169	.224	4.29	5.70
D	0.15	0.23	0.38	0.58
F	.043	.065	1.09	1.65
G	100 BASIC		2.54 BASIC	
H	.030	.090	0.76	2.29
J	.008	.015	0.20	0.38
K	.100	.136	2.54	3.46
L	600 BASIC		15.24 BASIC	
M	0°	15°	0°	15°
N	.018	.022	0.46	0.56

NOTE: Leads in true position within 0.010" (0.25mm) R at MMC at seating plane  
CASE: Plastic  
MATING CONNECTOR: 2803MC  
WEIGHT 4.3gm (0.15oz)

## TIMING DIAGRAMS

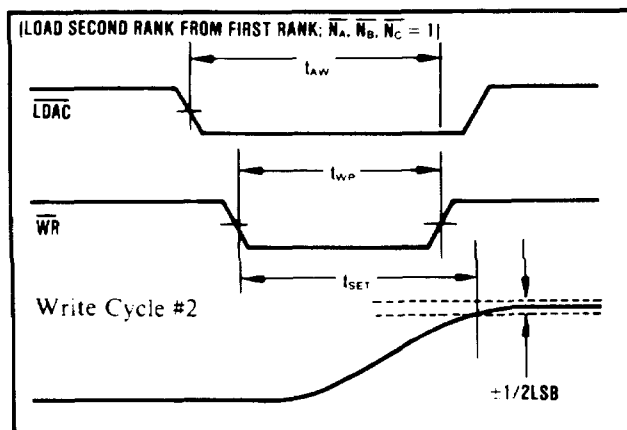
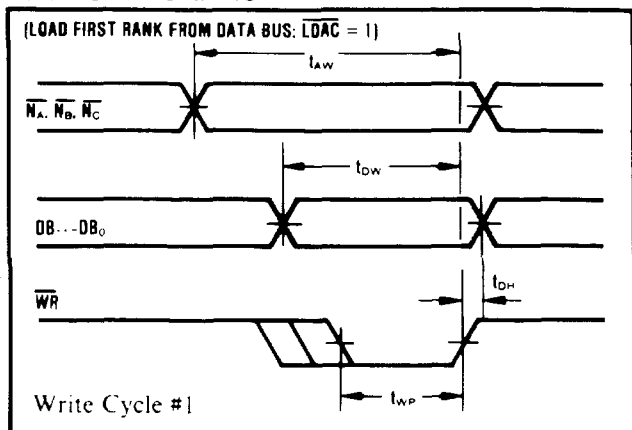

Digital Interface Timing Over Temperature Range

$t_{WP}$ ,  $\overline{WR}$  pulse width, min ..... 50ns

$t_{w1}$ ,  $\overline{N_x}$  and  $\overline{LDAC}$  valid to end of  $\overline{WR}$ , min ..... 50ns

$t_{DV}$ , data valid to end of  $\overline{WR}$ , min ..... 80ns

$t_{DH}$ , data valid hold time, min ..... 0ns

## PIN NOMENCLATURE

PIN	NAME	FUNCTION	PIN	NAME	FUNCTION
1	$V_{DD}$	Logic Supply, +5V	14	$D_4$	DATA, Bit 5
2	$\overline{WR}$	WRITE, command signal to load latches. Logic low loads latches.	15	DCOM	DIGITAL COMMON, $V_{DD}$ supply return
3	$\overline{LDAC}$	LOAD D/A CONVERTER, enables $\overline{WR}$ to load the D/A latch. Logic low enables.	16	$D_0$	DATA, Bit 1, LSB
4	$\overline{N_A}$	NYBBLE A, enables $\overline{WR}$ to load input latch A (the most significant nybble). Logic low enables.	17	$D_1$	DATA, Bit 2
5	$\overline{N_B}$	NYBBLE B, enables $\overline{WR}$ to load input latch B. Logic low enables.	18	$D_2$	DATA, Bit 3
6	$\overline{N_C}$	NYBBLE C, enables $\overline{WR}$ to load input latch C (the least significant nybble). Logic low enables.	19	$D_3$	DATA, Bit 4
7	$D_{12}$	DATA, Bit 12, MSB, positive true.	20	$-V_{CC}$	Analog Supply Input, +15V or +12V
8	$D_{10}$	DATA, Bit 11	21	$-V_{CC}$	Analog Supply Input, -15V or -12V
9	$D_9$	DATA, Bit 10	22	GAIN ADJ	To externally adjust gain
10	$D_8$	DATA, Bit 9	23	ACOM	ANALOG COMMON, $\pm V_{CC}$ supply return
11	$D_7$	DATA, Bit 8	24	$V_{out}$	D/A converter voltage output
12	$D_6$	DATA, Bit 7	25	10V RANGE	Connect to pin 24 for 10V Range
13	$D_5$	DATA, Bit 6	26	SJ	SUMMING JUNCTION of output amplifier
			27	BPO	BIPOLAR OFFSET. Connect to pin 26 for Bipolar Operation
			28	REF OUT	6.3V reference output

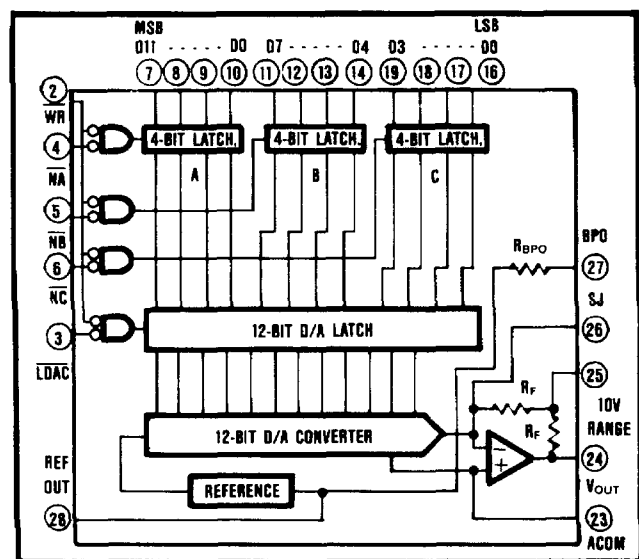

FIGURE 1. DAC1201 Block Diagram.

## OPERATION

### INTERFACE LOGIC

Input latches A, B, and C hold data temporarily while a complete 12-bit word is assembled before loading into the D/A register. This double-buffered organization prevents the generation of spurious analog output values. Each register is independently addressable.

These input latches are controlled by  $\overline{N_A}$ ,  $\overline{N_B}$ ,  $\overline{N_C}$  and  $\overline{WR}$ .  $\overline{N_A}$ ,  $\overline{N_B}$ , and  $\overline{N_C}$  are internally NORed with  $\overline{WR}$  so that the input latches transmit data when both  $\overline{N_A}$  (or  $\overline{N_B}$ ,  $\overline{N_C}$ ) and  $\overline{WR}$  are at logic "0". When either  $\overline{N_A}$  (or  $\overline{N_B}$ ,  $\overline{N_C}$ ) or  $\overline{WR}$  go to logic "1", the input data is latched into the input registers and held until both  $\overline{N_A}$  (or  $\overline{N_B}$ ,  $\overline{N_C}$ ) and  $\overline{WR}$  go to logic "0".

The D/A latch is controlled by  $\overline{LDAC}$  and  $\overline{WR}$ .  $\overline{LDAC}$  and  $\overline{WR}$  are internally NORed so that the latches

transmit data to the D/A switches when both  $\overline{\text{LDAC}}$  and  $\overline{\text{WR}}$  are at logic "0". When either  $\overline{\text{LDAC}}$  or  $\overline{\text{WR}}$  are at logic "1", the data is latched in the D/A latch and held until  $\overline{\text{LDAC}}$  and  $\overline{\text{WR}}$  go to logic "0".

All latches are level-triggered. Data present when the control signals are logic "0" will enter the latch. When any one of the control signals returns to logic "1", the data is latched. A truth table for all latches is given in Table I.

TABLE I. DAC1201 Interface Logic Truth Table.

WR	N <sub>A</sub>	N <sub>B</sub>	N <sub>C</sub>	LDAC	Operation
1	X	X	X	X	No Operation
0	0	1	1	1	Enables Input Latch 4MSBs
0	1	0	1	1	Enables Input Latch 4 Middle Bits
0	1	1	0	1	Enables Input Latch 4LSBs
0	1	1	1	0	Loads D/A Latch From Input Latches
0	0	0	0	0	All Latches Transparent

"X" = Don't Care.

### GAIN AND OFFSET ADJUSTMENTS

Figures 2 and 3 illustrate the relationship of Offset and Gain adjustments to unipolar and bipolar D/A converter output.

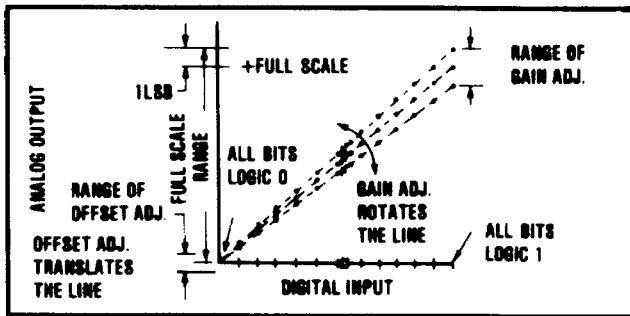

FIGURE 2. Relationship of Offset and Gain Adjustments for a Unipolar D/A Converter.

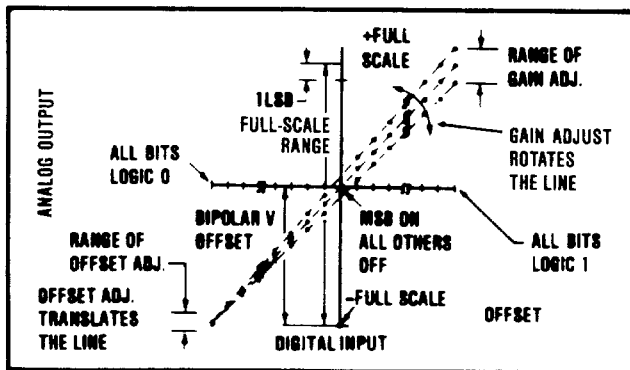

FIGURE 3. Relationship of Offset and Gain Adjustments for a Bipolar D/A Converter.

### OFFSET ADJUSTMENT

For unipolar (USB) configurations, apply the digital input code that should produce zero voltage output and adjust the Offset potentiometer for zero output. For bipolar (BOB, BTC) configurations, apply the digital input code that should produce the maximum negative output voltage and adjust the Offset potentiometer for minus full-scale voltage. Example: If the full-scale range

is connected for 20V, the maximum negative output voltage is  $-10\text{V}$ . See Table II for corresponding codes.

TABLE II. Digital Input/Analog Output,  $\pm V_{CC} = \pm 15\text{V}$ .

Digital Input 12-Bit Resolution MSB      LSB	Analog Output		
	0 to +10V	$\pm 5\text{V}$	$\pm 10\text{V}$
111111111111	+9.9976V	+4.9976V	+9.9951V
100000000000	+5.0000V	0.0000V	0.0000V
011111111111	+4.9976V	-0.0024V	-0.0049V
000000000000	0.0000V	-5.0000V	-10.0000V
1LSB	2.44mV	2.44mV	4.88mV

### GAIN ADJUSTMENT

For either unipolar or bipolar configurations, apply the digital input that should give the maximum positive voltage output. Adjust the Gain potentiometer for this positive full-scale voltage. See Table II for positive full-scale voltages.

### $\pm 12\text{V}$ OPERATION

The DAC1201 is fully specified for operation on  $\pm 12\text{V}$  power supplies. However, in order for the output to swing to  $\pm 10\text{V}$ , the power supplies must be  $\pm 13.5\text{V}$  or greater. When operating with  $\pm 12\text{V}$  supplies, the output swing should be restricted to  $\pm 8\text{V}$  in order to meet specifications.

## INSTALLATION

### POWER SUPPLY CONNECTIONS

Decoupling: For optimum performance and noise rejection, power supply decoupling capacitors should be added as shown in the Connection Diagram, Figure 4.

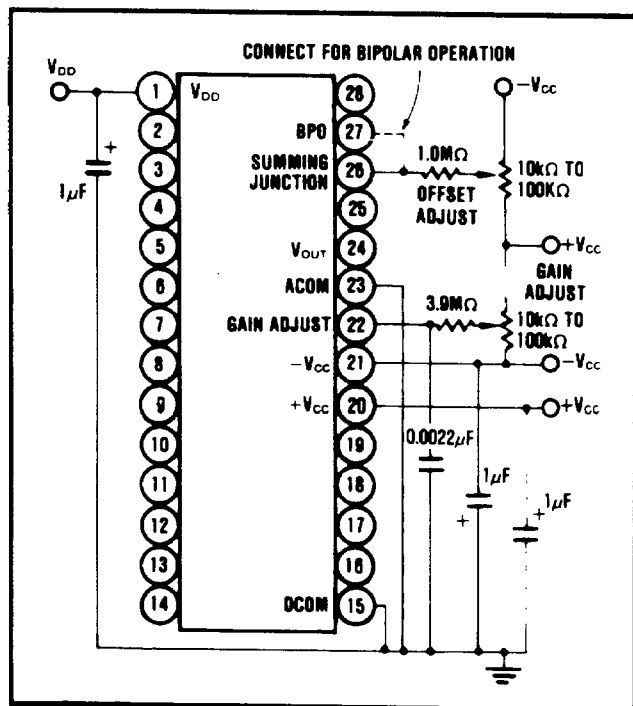

FIGURE 4. Power Supply, Gain, and Offset Potentiometer Connections.

These capacitors (1 $\mu$ F to 10 $\mu$ F tantalum recommended) should be located close to the DAC1201.

The DAC1201 features separate digital and analog power supply returns to permit optimum connections for low noise and high speed performance. The Analog Common (pin 23) and Digital Common (pin 15) should be connected together at one point. Separate returns minimize current flow in low-level signal paths if properly connected. Logic return currents are not added into the analog signal return path. A  $\pm 0.5$ V difference between ACOM and DCOM is permitted for specified operation. High frequency noise on DCOM with respect to ACOM may permit noise to be coupled through to the analog output; therefore, some caution is required in applying these common connections.

The Analog Common is the high quality return for the D/A converter and should be connected directly to the analog reference point of the system. The load driven by the output amplifier should be returned to the Analog Common.

### EXTERNAL OFFSET AND GAIN ADJUSTMENT

Offset and Gain may be trimmed by installing external Offset and Gain potentiometers. Connect these potentiometers as shown in Figure 4. TCR of the potentiometers should be 100ppm/ $^{\circ}$ C or less. The 1.0M $\Omega$  and 3.9M $\Omega$  resistors (20% carbon or better) should be located close to the DAC1201 to prevent noise pick-up. If it is not convenient to use these high value resistors, and equivalent "T" network, as shown in Figure 5, may be substituted in each case. The Gain Adjust (pin 22) is a high impedance point and a 0.001 $\mu$ F to 0.01 $\mu$ F ceramic capacitor should be connected from this pin to Analog Common to reduce noise pick-up in all applications, including those not employing external gain adjustment.

### OUTPUT RANGE CONNECTIONS

Internal-scaling resistors provided in the DAC1201 may be connected to produce bipolar output voltage ranges of  $\pm 10$ V and  $\pm 5$ V or unipolar output voltage range of 0

to +10V. The 20V range ( $\pm 10$ V bipolar range) is internally connected. Refer to Figure 6. Connections for the output ranges are listed in Table III.

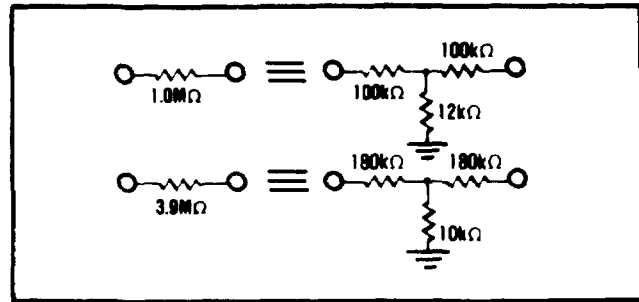

FIGURE 5. Equivalent Resistances.

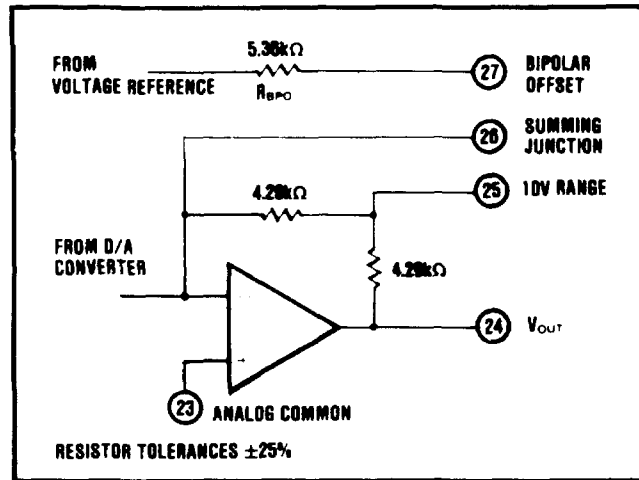

FIGURE 6. Output Amplifier Voltage Range Scaling Circuit.

TABLE III. Output Range Connections.

Output Range	Digital Input Codes	Connect Pin 25 To	Connect Pin 27 To
0 to +10V	USB	24	23
$\pm 5$ V	BOB or BTC	24	26
$\pm 10$ V	BOB or BTC	NC	26