



DB-85015-940

RF power amplifier using 1 x PD85015-E N-channel enhancement-mode lateral MOSFETs

Features

- Excellent thermal stability
- Frequency: 860 - 940 MHz
- Supply voltage: 13.6 V
- Output power: 10 W
- Power gain: 15.7 ± 0.4 dB
- Efficiency: 60% - 62%
- Load mismatch: 20:1
- BeO free amplifier

Description

The DB-85015-940 is a common source N-channel enhancement-mode lateral field effect RF power amplifier designed for UHF radio applications.

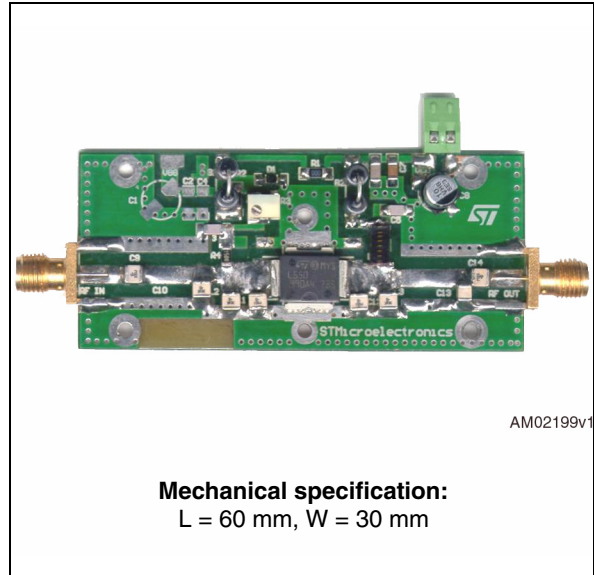

Table 1. Device summary

Order codes
DB-85015-940

Contents

www.datasheet4u.com

- 1 Electrical data 3**
 - 1.1 Maximum ratings 3
- 2 Electrical characteristics 3**
- 3 Impedance 4**
- 4 Typical performance 5**
 - 4.1 VDD = 13.6 V, IDQ = 200 mA, PIN = 25 dBm 5
- 5 Circuit photo 6**
- 6 Test circuit 7**
- 7 Mounting indications 9**
- 8 Package mechanical data 10**
- 9 Revision history 13**



1 Electrical data

1.1 Maximum ratings

www.datasheet4u.com

Table 2. Absolute maximum ratings

Symbol	Parameter	Value	Unit
V_{DD}	Supply voltage	24	V
I_D	Drain current	3	A
P_{DISS}	Power dissipation	25	W
T_{CASE}	Operating case temperature	-20 to +85	°C
T_A	Max. ambient temperature	55	°C

2 Electrical characteristics

$T_A = +25\text{ °C}$, $V_{DD} = 13.6\text{ V}$, $I_{DQ} = 200\text{ mA}$

Table 3. Electrical specification

Symbol	Test conditions	Min.	Typ.	Max.	Unit
Freq	Frequency range	860		940	MHz
P_{OUT}	@ $P_{IN} = 25\text{ dBm}$	10			W
Gain	@ $P_{IN} = 25\text{ dBm}$		15.7 ± 0.4		dB
ND	@ $P_{IN} = 25\text{ dBm}$		60 - 62		%
H2	2 ND harmonic @ $P_{IN} = 25\text{ dBm}$			-40	dBc
H3	3 RD harmonic @ $P_{IN} = 25\text{ dBm}$			-50	dBc
VSWR	Load mismatch all phases @ $P_{IN} = 25\text{ dBm}$			20:1	

3 Impedance

www.datasheet4u.com

Figure 1. Impedance graphic

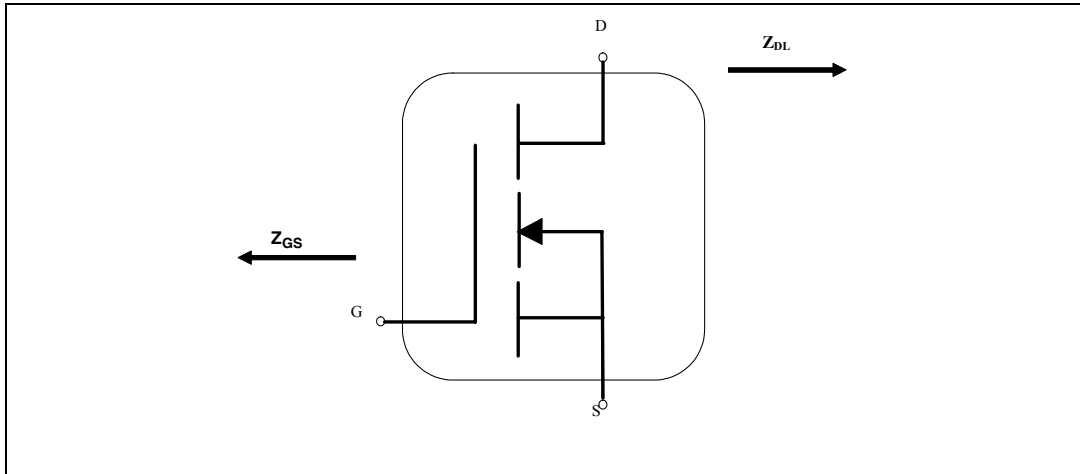

Table 4. Impedance data

f(MHz)	$Z_{GS} (\Omega)$	$Z_{DL} (\Omega)$
860	1,61 + j1,43	2,67 + j3,62
870	1,60 + j1,67	2,62 + j3,76
880	1,49 + j1,82	2,58 + j3,91
890	1,43 + j2,05	2,52 + j4,05
900	1,37 + j2,23	2,49 + j4,19
910	1,31 + j2,41	2,43+ j4,29
920	1,28 + j2,58	2,36 + j4,46
930	1,19 + j2,77	2,28 + j4,59
940	1,14 + j2,96	2,18 + j 4,67

4 Typical performance

4.1 $V_{DD} = 13.6\text{ V}$, $I_{DQ} = 200\text{ mA}$, $P_{IN} = 25\text{ dBm}$

www.datasheet4u.com

Figure 2. Output power and drain current vs frequency_
 $V_{dd} = 13.6\text{ V}$, $I_{dq} = 200\text{ mA}$, $P_{in} = 25\text{ dBm}$

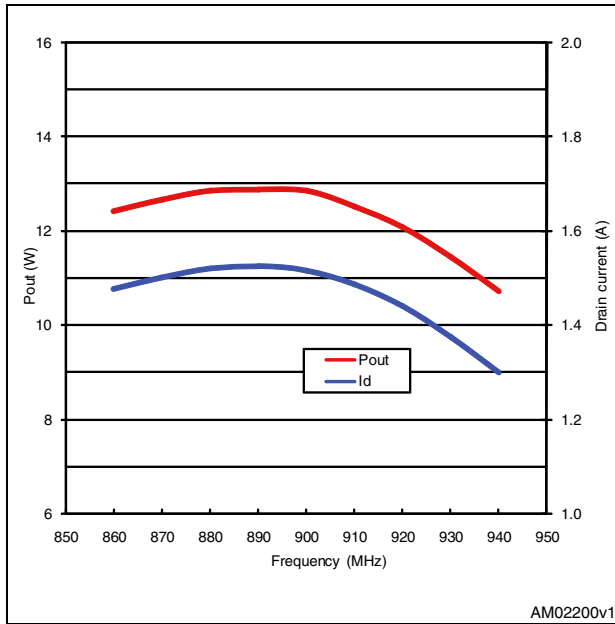

Figure 3. Gain and efficiency vs frequency_
 $V_{dd} = 13.6\text{ V}$, $I_{dq} = 200\text{ mA}$, $P_{in} = 25\text{ dBm}$

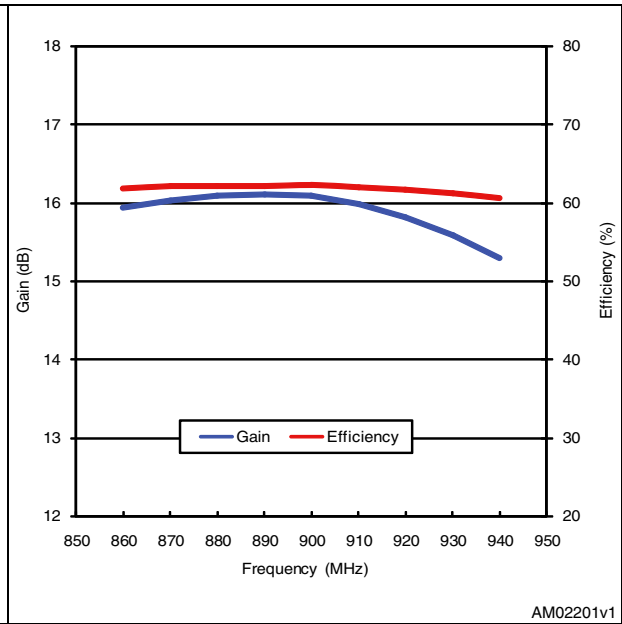

Figure 4. Input return loss vs frequency_
 $V_{dd} = 13.6\text{ V}$, $I_{dq} = 200\text{ mA}$, $P_{in} = 25\text{ dBm}$

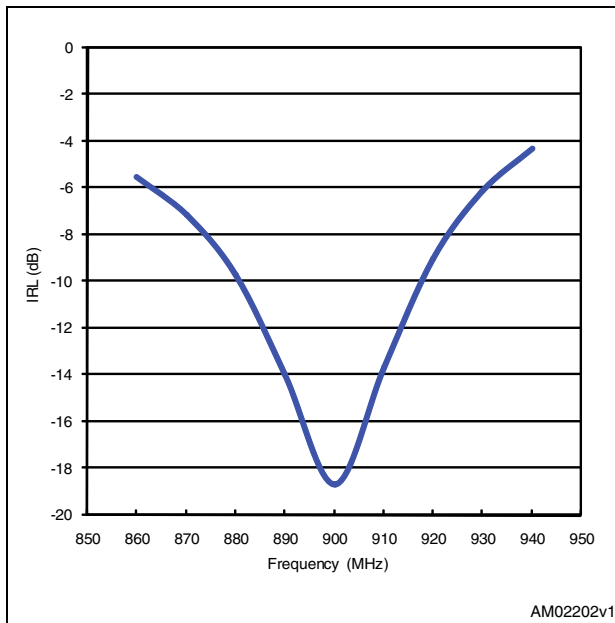
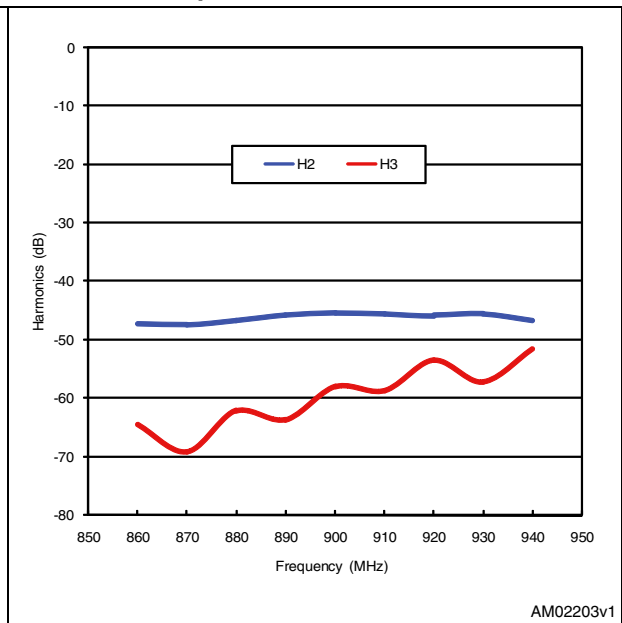

Figure 5. Harmonics vs frequency_
 $V_{dd} = 13.6\text{ V}$, $I_{dq} = 200\text{ mA}$, $P_{in} = 25\text{ dBm}$



5 Circuit photo

www.datasheet4u.com

Figure 6. Circuit photo

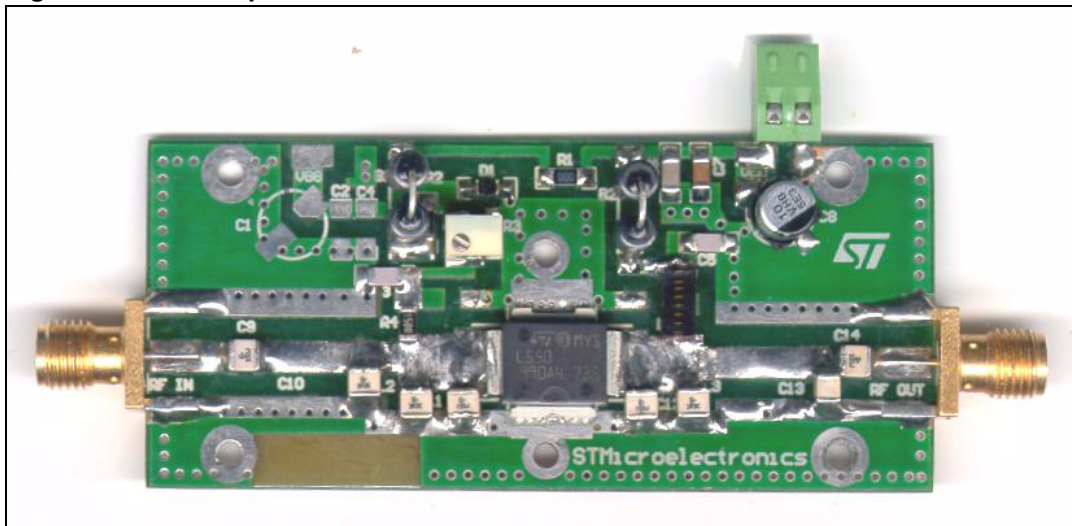

6 Test circuit

Table 5. Test circuit schematic

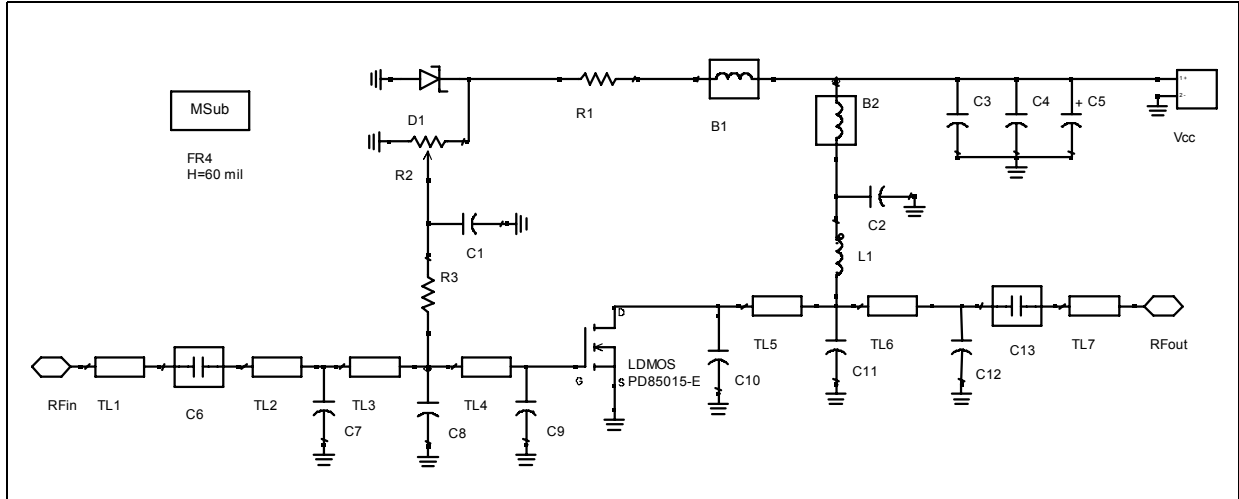

Table 6. Components part list for DB-85015-940

Component ID	Description	Value	Case size	Manufacturer	Part code
B1	Ferrite bead			Panasonic	EXCELDR35C
B2	Ferrite bead			Panasonic	EXCELDR35C
C1, C2	Capacitor	120 pF	1206	Murata	GRM42-6 COG 121J 50
C3	Capacitor	1 nF	1206	Murata	GRM42-6 COG 102J 50
C4	Capacitor	100 nF	1206	Murata	GRM42-6_X7R 104K 50
C5	Capacitor	10 μF	SMT	Panasonic	EEVHB1V100P
C6, C13	Capacitor	33 pF	1111	Murata	MA69330JAB
C7	Capacitor	2.2 pF	1111	Murata	MA692R2CAB
C8, C11	Capacitor	3.3 pF	1111	Murata	MA693R3CAB
C9, C10	Capacitor	15 pF	1111	Murata	MA69150JAB
C12	Capacitor	4.7 pF	1111	Murata	MA694R7CAB
D1	Zener diode	5.1 V	SOD110	Philips	BZX284C5V1
L1	Inductor	28 nH		Coilcraft	B08T
R1	Resistor	1 kΩ	1206	Tyco electronics	01623440-1
R2	Potentiometer	10 kΩ		Bourns electronics	3214W-1-103E
R3	Resistor	150 Ω	1206	Bourns electronics	
TL1	Transmission line	W=2.87 mm	L=7.4 mm		
TL2	Transmission line	W=2.87 mm	L=8,0 mm		
TL3	Transmission line	W=4.98 mm	L=1,4 mm		

Table 6. Components part list for DB-85015-940 (continued)

Component ID	Description	Value	Case size	Manufacturer	Part code
TL4	Transmission line	W=4.98 mm	L=1,2 mm		
TL5	Transmission line	W=4.98 mm	L=1,3 mm		
TL6	Transmission line	W=2.87 mm	L=9,5 mm		
TL7	Transmission line	W=2.87 mm	L=5,8 mm		
PD85015-E	LDMOS			STMicroelectronics	PD85015-E
Board	FR-4 THk=0.060" 2 OZ Cu both sides				

7 Mounting indications

www.datasheet4u.com

Figure 7. PowerSO-10 mounting indications

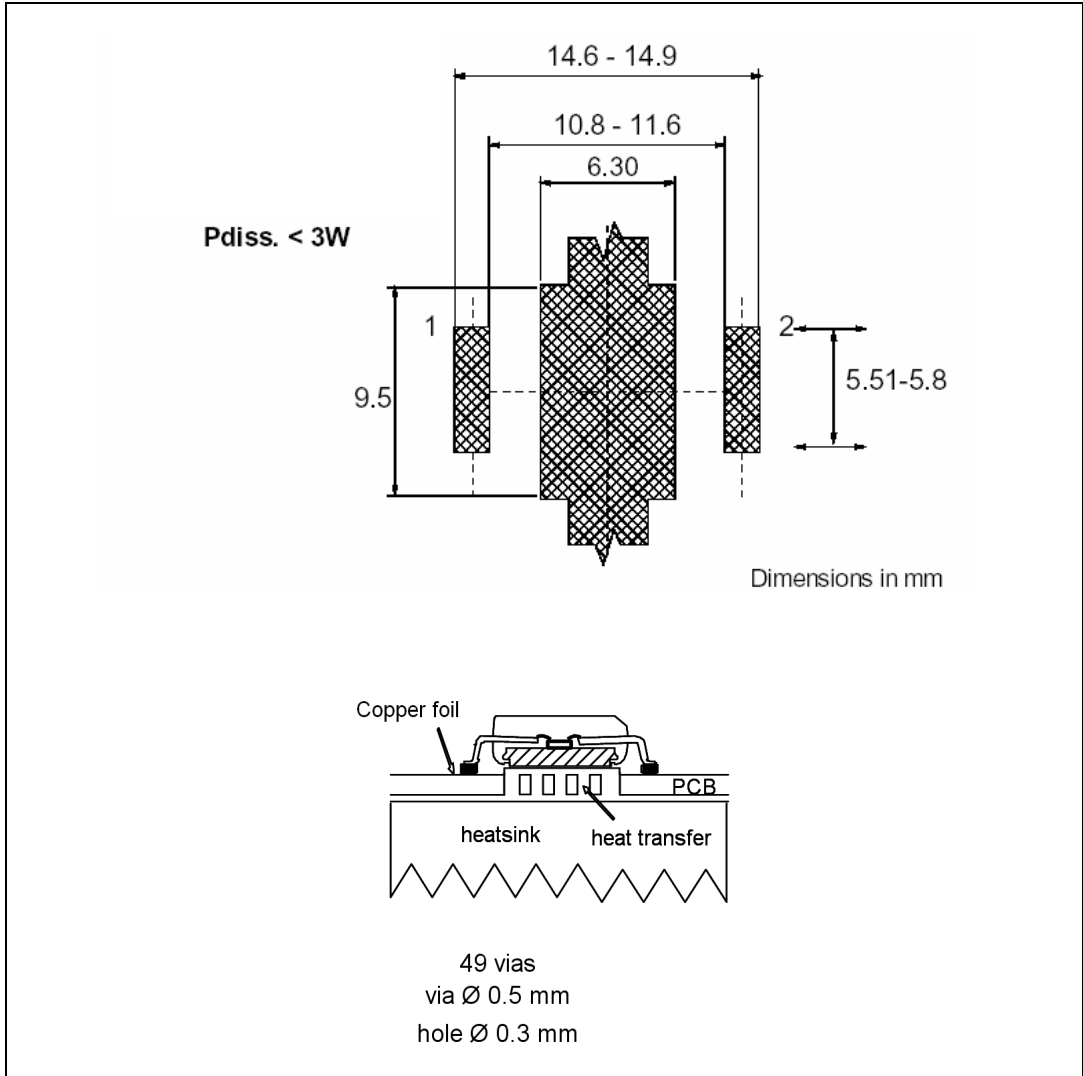

8 Package mechanical data

www.datasheet4u.com

In order to meet environmental requirements, ST offers these devices in different grades of ECOPACK® packages, depending on their level of environmental compliance. ECOPACK® specifications, grade definitions and product status are available at: www.st.com. ECOPACK is an ST trademark.

Table 7. PowerSO-10RF formed lead (gull wing) mechanical data

Dim.	mm.			Inch		
	Min.	Typ.	Max.	Min.	Typ.	Max.
A1	0	0.05	0.1	0.	0.0019	0.0038
A2	3.4	3.5	3.6	0.134	0.137	0.142
A3	1.2	1.3	1.4	0.046	0.05	0.054
A4	0.15	0.2	0.25	0.005	0.007	0.009
a		0.2			0.007	
b	5.4	5.53	5.65	0.212	0.217	0.221
c	0.23	0.27	0.32	0.008	0.01	0.012
D	9.4	9.5	9.6	0.370	0.374	0.377
D1	7.4	7.5	7.6	0.290	0.295	0.298
E	13.85	14.1	14.35	0.544	0.555	0.565
E1	9.3	9.4	9.5	0.365	0.37	0.375
E2	7.3	7.4	7.5	0.286	0.292	0.294
E3	5.9	6.1	6.3	0.231	0.24	0.247
F		0.5			0.019	
G		1.2			0.047	
L	0.8	1	1.1	0.030	0.039	0.042
R1			0.25			0.01
R2		0.8			0.031	
T	2 deg	5 deg	8 deg	2 deg	5 deg	8 deg
T1		6 deg			6 deg	
T2		10 deg			10 deg	

www.datasheet4u.com

Note: Resin protrusions not included (max value: 0.15 mm per side)

Figure 8. Package dimensions

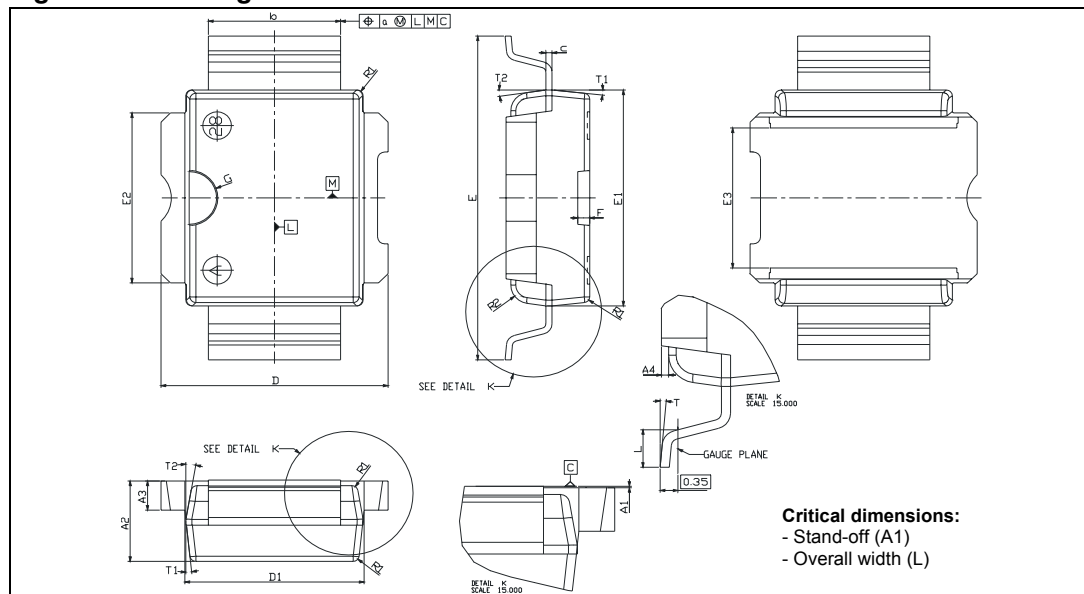
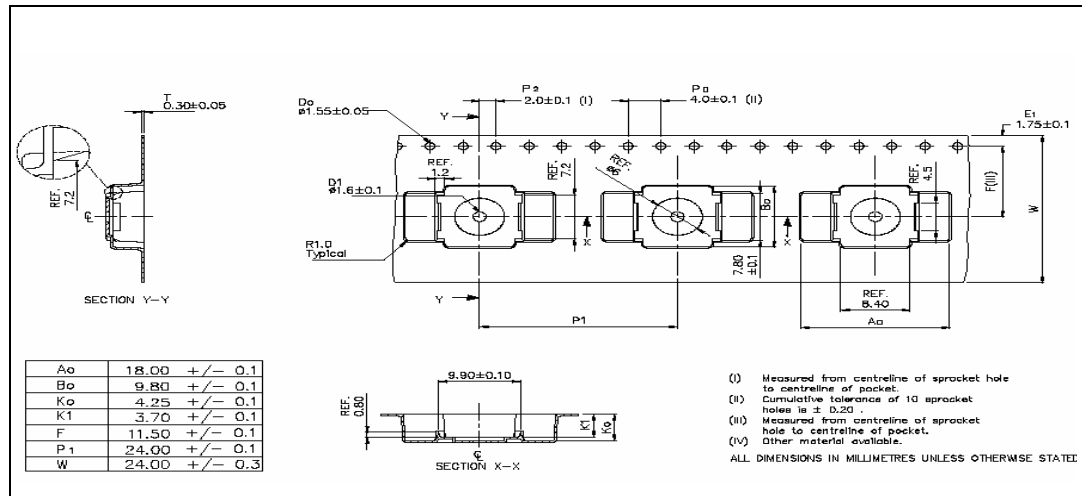

Figure 9. PowerSO-10RF tape and reel

www.datasheet4u.com



9 Revision history

www.datasheet4u.com

Table 8. Document revision history

Date	Revision	Changes
25-Mar-2009	1	Initial release

Please Read Carefully:

Information in this document is provided solely in connection with ST products. STMicroelectronics NV and its subsidiaries ("ST") reserve the right to make changes, corrections, modifications or improvements, to this document, and the products and services described herein at any time, without notice.

All ST products are sold pursuant to ST's terms and conditions of sale.

Purchasers are solely responsible for the choice, selection and use of the ST products and services described herein, and ST assumes no liability whatsoever relating to the choice, selection or use of the ST products and services described herein.

No license, express or implied, by estoppel or otherwise, to any intellectual property rights is granted under this document. If any part of this document refers to any third party products or services it shall not be deemed a license grant by ST for the use of such third party products or services, or any intellectual property contained therein or considered as a warranty covering the use in any manner whatsoever of such third party products or services or any intellectual property contained therein.

UNLESS OTHERWISE SET FORTH IN ST'S TERMS AND CONDITIONS OF SALE ST DISCLAIMS ANY EXPRESS OR IMPLIED WARRANTY WITH RESPECT TO THE USE AND/OR SALE OF ST PRODUCTS INCLUDING WITHOUT LIMITATION IMPLIED WARRANTIES OF MERCHANTABILITY, FITNESS FOR A PARTICULAR PURPOSE (AND THEIR EQUIVALENTS UNDER THE LAWS OF ANY JURISDICTION), OR INFRINGEMENT OF ANY PATENT, COPYRIGHT OR OTHER INTELLECTUAL PROPERTY RIGHT.

UNLESS EXPRESSLY APPROVED IN WRITING BY AN AUTHORIZED ST REPRESENTATIVE, ST PRODUCTS ARE NOT RECOMMENDED, AUTHORIZED OR WARRANTED FOR USE IN MILITARY, AIR CRAFT, SPACE, LIFE SAVING, OR LIFE SUSTAINING APPLICATIONS, NOR IN PRODUCTS OR SYSTEMS WHERE FAILURE OR MALFUNCTION MAY RESULT IN PERSONAL INJURY, DEATH, OR SEVERE PROPERTY OR ENVIRONMENTAL DAMAGE. ST PRODUCTS WHICH ARE NOT SPECIFIED AS "AUTOMOTIVE GRADE" MAY ONLY BE USED IN AUTOMOTIVE APPLICATIONS AT USER'S OWN RISK.

Resale of ST products with provisions different from the statements and/or technical features set forth in this document shall immediately void any warranty granted by ST for the ST product or service described herein and shall not create or extend in any manner whatsoever, any liability of ST.

ST and the ST logo are trademarks or registered trademarks of ST in various countries.

Information in this document supersedes and replaces all information previously supplied.

The ST logo is a registered trademark of STMicroelectronics. All other names are the property of their respective owners.

© 2009 STMicroelectronics - All rights reserved

STMicroelectronics group of companies

Australia - Belgium - Brazil - Canada - China - Czech Republic - Finland - France - Germany - Hong Kong - India - Israel - Italy - Japan - Malaysia - Malta - Morocco - Singapore - Spain - Sweden - Switzerland - United Kingdom - United States of America

www.st.com