



DC COMPONENTS CO., LTD.

DISCRETE SEMICONDUCTORS

DC9014

TECHNICAL SPECIFICATIONS OF NPN EPITAXIAL PLANAR TRANSISTOR

Description

Designed for use in pre-amplifier of low level and low noise.

Pinning

- 1 = Emitter
- 2 = Base
- 3 = Collector

Absolute Maximum Ratings (TA=25°C)

Characteristic	Symbol	Rating	Unit
Collector-Base Voltage	V _{CB0}	50	V
Collector-Emitter Voltage	V _{CEO}	45	V
Emitter-Base Voltage	V _{EBO}	5	V
Collector Current	I _C	100	mA
Total Power Dissipation	P _D	450	mW
Junction Temperature	T _J	+150	°C
Storage Temperature	T _{STG}	-55 to +150	°C

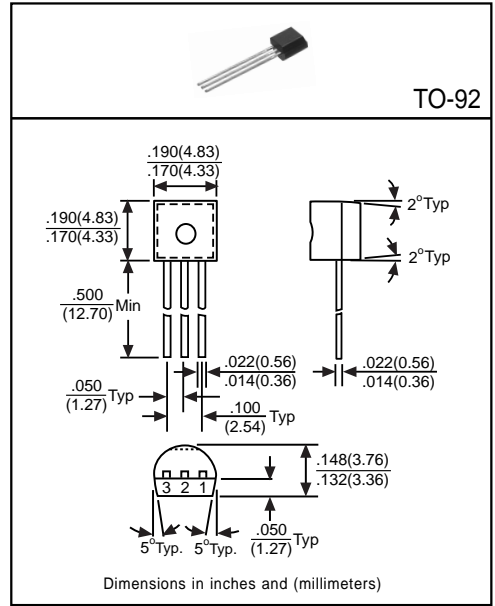

Electrical Characteristics

(Ratings at 25°C ambient temperature unless otherwise specified)

Characteristic	Symbol	Min	Typ	Max	Unit	Test Conditions
Collector-Base Breakdown Voltage	BV _{CB0}	50	-	-	V	I _C =100μA, I _E =0
Collector-Emitter Breakdown Voltage	BV _{CEO}	45	-	-	V	I _C =1mA, I _B =0
Emitter-Base Breakdown Voltage	BV _{EBO}	5	-	-	V	I _E =100μA, I _C =0
Collector Cutoff Current	I _{CBO}	-	-	50	nA	V _{CB} =50V, I _E =0
Emitter Cutoff Current	I _{EBO}	-	-	50	nA	V _{EB} =5V, I _C =0
Collector-Emitter Saturation Voltage ⁽¹⁾	V _{CE(sat)}	-	0.14	0.3	V	I _C =100mA, I _B =5mA
Base-Emitter Saturation Voltage ⁽¹⁾	V _{BE(sat)}	-	0.84	1	V	I _C =100mA, I _B =5mA
Base-Emitter On Voltage	V _{BE(on)}	0.58	0.63	0.7	V	I _C =2mA, V _{CE} =5V
DC Current Gain ⁽¹⁾	h _{FE}	60	280	1000	-	I _C =1mA, V _{CE} =5V
Transition Frequency	f _T	150	270	-	MHz	I _C =10mA, V _{CE} =5V
Output Capacitance	C _{ob}	-	2.2	3.5	pF	V _{CB} =10V, f=1MHz, I _E =0

(1)Pulse Test: Pulse Width ≤ 380μs, Duty Cycle ≤ 2%

Classification of hFE

Rank	A	B	C	D
Range	60~150	100~300	200~600	400~1000