

N-Channel Enhancement Mode
Avalanche Rated
Low Q_g and R_g
High dv/dt
Nanosecond Switching

Preliminary Data Sheet

$V_{DSS} = 500 \text{ V}$
 $I_{D25} = 16 \text{ A}$
 $R_{DS(on)} = .5 \Omega$
 $P_{DHS} = 375 \text{ W}$

Symbol	Test Conditions	Maximum Ratings	
V_{DSS}	$T_J = 25^\circ\text{C}$ to 150°C	500	V
V_{DGR}	$T_J = 25^\circ\text{C}$ to 150°C ; $R_{GS} = 1 \text{ M}\Omega$	500	V
V_{GS}	Continuous	± 20	V
V_{GSM}	Transient	± 30	V
I_{D25}	$T_c = 25^\circ\text{C}$	16	A
I_{DM}	$T_c = 25^\circ\text{C}$, pulse width limited by T_{JM}	98	A
I_{AR}	$T_c = 25^\circ\text{C}$	16	A
E_{AR}	$T_c = 25^\circ\text{C}$	20	mJ
dv/dt	$I_S \leq I_{DM}$, $di/dt \leq 100 \text{ A}/\mu\text{s}$, $V_{DD} \leq V_{DSS}$, $T_J \leq 150^\circ\text{C}$, $R_G = 0.2 \Omega$	5	V/ns
	$I_S = 0$	>200	V/ns
P_{DHS}	$T_c = 25^\circ\text{C}$ Derate $3.0 \text{ W}/^\circ\text{C}$ above 25°C	375	W
P_{DAMB}	$T_c = 25^\circ\text{C}$	3.0	W
R_{thJHS}		0.33	K/W
T_J		-55...+150	$^\circ\text{C}$
T_{JM}		150	$^\circ\text{C}$
T_{stg}		-55...+150	$^\circ\text{C}$
T_L	1.6mm (0.063 in) from case for 10 s	300	$^\circ\text{C}$
Weight		2	g

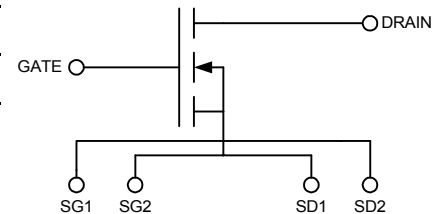
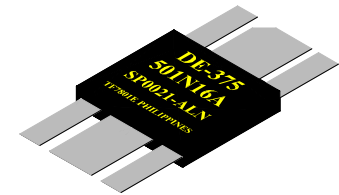

Features

- Isolated Substrate
 - high isolation voltage (>2500V)
 - excellent thermal transfer
 - Increased temperature and power cycling capability
- IXYS advanced low Q_g process
- Low gate charge and capacitances
 - easier to drive
 - faster switching
- Low $R_{DS(on)}$
- Very low insertion inductance (<2nH)
- No beryllium oxide (BeO) or other hazardous materials

Advantages

- Optimized for RF and high speed switching at frequencies to 100MHz
- Easy to mount—no insulators needed
- High power density

Symbol	Test Conditions	Characteristic Values		
		$T_J = 25^\circ\text{C}$ unless otherwise specified		
		min.	typ.	max.
V_{DSS}	$V_{GS} = 0 \text{ V}$, $I_D = 3 \text{ ma}$	500		V
$V_{GS(th)}$	$V_{DS} = V_{GS}$, $I_D = 4 \text{ ma}$	2.5		5.5 V
I_{GSS}	$V_{GS} = \pm 20 \text{ V}_{DC}$, $V_{DS} = 0$			$\pm 100 \text{ nA}$
I_{DSS}	$V_{DS} = 0.8 V_{DSS}$, $T_J = 25^\circ\text{C}$ $V_{GS} = 0$, $T_J = 125^\circ\text{C}$			50 μA 1 mA
$R_{DS(on)}$	$V_{GS} = 15 \text{ V}$, $I_D = 0.5 I_{D25}$ Pulse test, $t \leq 300 \mu\text{s}$, duty cycle $d \leq 2\%$.5 Ω
g_{fs}	$V_{DS} = 15 \text{ V}$, $I_D = 0.5 I_{D25}$, pulse test	2	6	S

Symbol	Test Conditions	Characteristic Values ($T_J = 25^\circ\text{C}$ unless otherwise specified)		
		min.	typ.	max.
R_G			0.3	Ω
C_{iss}			1800	pF
C_{oss}	$V_{GS} = 0\text{ V}, V_{DS} = 0.8 V_{DSS(max)},$ $f = 1\text{ MHz}$		150	pF
C_{rss}			45	pF
$T_{d(on)}$			3	ns
T_{on}	$V_{GS} = 15\text{ V}, V_{DS} = 0.8 V_{DSS}$ $I_D = 0.5 I_{DM}$		2	ns
$T_{d(off)}$	$R_G = 0.2\ \Omega$ (External)		4	ns
T_{off}			5	ns
$Q_{g(on)}$			50	nC
Q_{gs}	$V_{GS} = 10\text{ V}, V_{DS} = 0.5 V_{DSS}$ $I_D = 0.5 I_{D25}$		20	nC
Q_{gd}			30	nC

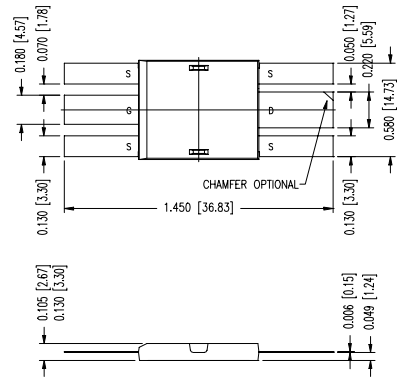

Symbol	Test Conditions	Characteristic Values ($T_J = 25^\circ\text{C}$ unless otherwise specified)		
		min.	typ.	max.
I_S	$V_{GS} = 0\text{ V}$			6 A
I_{SM}	Repetitive; pulse width limited by T_{JM}			48 A
V_{SD}	$I_F = I_S, V_{GS} = 0\text{ V},$ Pulse test, $t \leq 300\ \mu\text{s},$ duty cycle $\leq 2\%$			1.5 V
T_{rr}			200	ns
Q_{RM}	$I_F = I_S, -di/dt = 100\text{ A}/\mu\text{s},$ $V_R = 100\text{ V}$		0.6	μC
I_{RM}			4	A

501N16A DE-SERIES SPICE Model

The DE-SERIES SPICE Model is illustrated in Figure 1. The model is an expansion of the SPICE level 3 MOSFET model. It includes the stray inductive terms L_G , L_S and L_D . R_d is the $R_{DS(ON)}$ of the device, R_{ds} is the resistive leakage term. The output capacitance, C_{OSS} , and reverse transfer capacitance, C_{RSS} are modeled with reversed biased diodes. This provides a varactor type response necessary for a high power device model. The turn on delay and the turn off delay are adjusted via R_{on} and R_{off} .

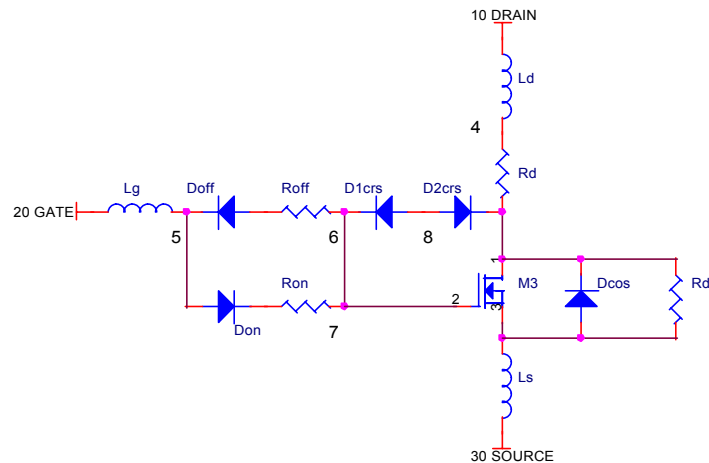

Figure 1 DE-SERIES SPICE Model

This SPICE model may be downloaded as a text file from the DEI web site at www.directedenergy.com/spice.htm

Net List:

SYM=POWMOSN

.SUBCKT 501N16A 10 20 30

* TERMINALS: D G S

* 500 Volt 16 Amp .5 ohm N-Channel Power MOSFET

* REVA 6-15-00

M1 1 2 3 3 DMOS L=1U W=1U

RON 5 6 .2

DON 6 2 D1

ROF 5 7 .2

DOF 2 7 D1

D1CRS 2 8 D2

D2CRS 1 8 D2

CGS 2 3 2.0N

RD 4 1 .5

DCOS 3 1 D3

RDS 1 3 5.0MEG

www.DataSheet4U.com

LS 3 30 .5N

LD 10 4 1N

LG 20 5 1N

.MODEL DMOS NMOS (LEVEL=3 VTO=3.0 KP=5.8)

.MODEL D1 D (IS=.5F CJO=10P BV=100 M=.5 VJ=.7 TT=1N RS=10M)

.MODEL D2 D (IS=.5F CJO=450P BV=500 M=.4 VJ=.6 TT=10N RS=10M)

.MODEL D3 D (IS=.5F CJO=900P BV=500 M=.3 VJ=.3 TT=400N RS=10M)

.ENDS

Doc #9200-0222 Rev 1

© 2001 Directed Energy, Inc.



Directed Energy, Inc.

An IXYS Company

2401 Research Blvd., Suite 108

Fort Collins, CO USA 80526

970-493-1901 Fax: 970-493-1903

Email: deiinfo@directedenergy.com

Web: <http://www.directedenergy.com>

www.DataSheet4U.com