

Display Elektronik GmbH

# DATA SHEET

***TFT MODULE***

**DEM 4801280A VMH-PW-N**

**6,8" TFT**

Product Specification

Ver.: 0

18.01.2017

**Revision History**

<b>Revision</b>	<b>Date</b>	<b>Originator</b>	<b>Detail</b>	<b>Remarks</b>
0	18.01.2017	MH	Initial Release	-

**Table of Contents**

No.	Item	Page
1.	General Description .....	4
2.	Module Parameter .....	4
3.	Absolute Maximum Ratings .....	4
4.	DC Characteristics .....	5
5.	Backlight Characteristic .....	5
5.1.	Backlight Characteristic .....	5
5.2.	Backlight Characteristic .....	5
6.	Optical Characteristics .....	6
6.1.	Optical Characteristics .....	6
6.2.	Definition of Response Time .....	6
6.3.	Definition of Contrast Ratio .....	7
6.4.	Definition of Viewing Angles .....	7
6.5.	Definition of Color Appearance .....	8
6.6.	Definition of Surface Luminance, Uniformity and Transmittance .....	8
7.	Block Diagram and Power Supply .....	9
8.	Interface Pins Definition .....	10
9.	AC Characteristics .....	11
9.1.	MIPI Input timing .....	11
9.2.	MIPI AC characteristics .....	11
10.	Reset timing .....	13
11.	Quality Assurance .....	14
11.1.	Purpose .....	14
11.2.	Standard for Quality Test .....	14
11.3.	Nonconforming Analysis & Disposition .....	14
11.4.	Agreement Items .....	14
11.5.	Standard of the Product Visual Inspection .....	15
11.6.	Inspection Specification .....	15
11.7.	Classification of Defects .....	19
11.8.	Identification/marketing criteria .....	19
11.9.	Packaging .....	19
12.	Reliability Specification .....	20
13.	Precautions and Warranty .....	21
13.1	Safety .....	21
13.2.	Handling .....	21
13.3.	Storage .....	21
13.4.	Metal Pin (Apply to Products with Metal Pins) .....	21
13.5.	Operation .....	22
13.6.	Static Electricity .....	22
13.7.	Limited Warranty .....	22
14.	Packaging .....	23
15.	Outline Drawing .....	24

## 1. General Description

The specification is a transmissive type color active matrix liquid crystal display (LCD) which uses amorphous thin film transistor (TFT) as switching devices. This product is composed of a TFT-LCD panel, driver Ics and a backlight unit.

## 2. Module Parameter

Features	Details	Unit
Display Size (Diagonal)	6.8"	-
LCD Type	IPS TFT	-
Display Mode	Transmissive / Normally black	-
Resolution	480 x RGB x 1280	Pixels
View Direction	FULL VIEW	Best Image
Module Outline	66.12 x 171.79 x 2.50 (Note1 )	mm
Active Area	60.22 x 160.59	mm
Pixel Size	0.12546 x 0.12546	mm
Pixel Arrangement	Stripe	-
Display Colors	16.7 Million	-
Interface	MIPI	-
With or without touch panel	Without	-
Driver IC	EK79030	-
Operating Temperature	-20°C to +60°C	°C
Storage Temperature	-20°C to +65°C	°C
Weight	t.b.d.	g

Note 1: Exclusive hooks, posts, FFC/FPC tail etc.

## 3. Absolute Maximum Ratings

$V_{SS}=0V, T_a=25^{\circ}C$

Item	Symbol	Min.	Max.	Unit
Supply Voltage	VCI	2.5	6.0	V
	IOVCC	1.8	5.5	
Storage Temperature	T <sub>STG</sub>	-20	+65	°C
Operating Temperature	T <sub>OP</sub>	-20	+60	°C

Note 1: If  $T_a$  below 50°C, the maximal humidity is 90%RH, if  $T_a$  over 50°C, absolute humidity should be less than 60%RH.

Note 2: The response time will be extremely slow when the operating temperature is around -10°C, and the back ground will become darker at high temperature operating.

4. DC Characteristics

Item	Symbol	Min.	Typ.	Max.	Unit	
Supply Voltage	V <sub>CI</sub>	2.5	3.3	3.6	V	
	IOVCC	1.8	3.3	3.6		
VDDIO Input Low Level Voltage	V <sub>IL</sub>	VSS	-	0.2*IOVCC	mV	
VDDIO Input High Level Voltage	V <sub>IH</sub>	0.8*IOVCC	-	IOVCC	mV	
Current Consumption All Black	Logic Analog	I <sub>CC+</sub> I <sub>IN</sub>	-	t.b.d.	-	mA

5. Backlight Characteristic

5.1. Backlight Characteristic

Item	Symbol	Condition	Min.	Typ.	Max.	Unit
Forward Voltage	V <sub>F</sub>	T <sub>a</sub> =25 °C, I <sub>F</sub> =20mA/LED	11.0	12.0	13.0	V
Forward Current	I <sub>F</sub>	T <sub>a</sub> =25 °C, V <sub>F</sub> =6V/LED		120		mA
Power Dissipation	P <sub>D</sub>		-	1440	-	mW
Uniformity	Avg		70	80	-	%
LED Lifetime		T <sub>a</sub> =25 °C	20000	30000	-	Hrs
Drive Method	Constant Current					
LED Configuration	12 White LEDs (2 LEDs in one string and 6 groups in parallel)					

Note1: LED life time defined as follows: The final brightness is at 50% of original brightness.  
The environmental conducted under ambient air flow, at T<sub>a</sub>=25±2 °C, 60%RH±5%, I<sub>F</sub>=20mA

5.2. Backlight Characteristic

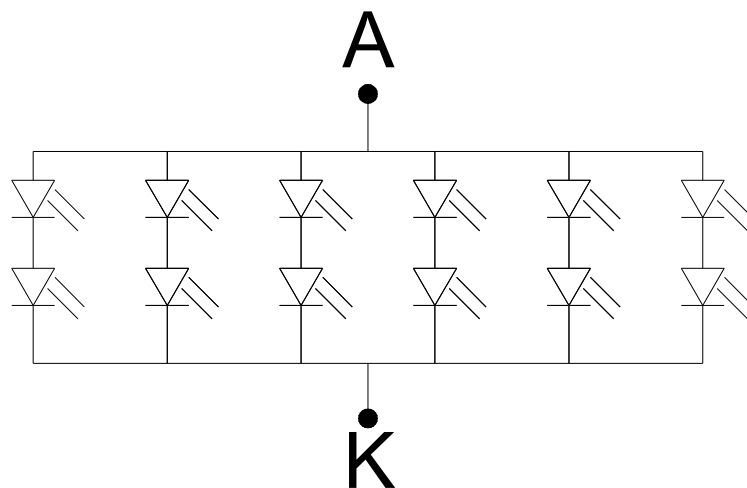

Circuit Diagram:  
Double Core Lamp

6. Optical Characteristics

6.1. Optical Characteristics

Ta=25°C, VCI=3.3V, TN LC+ Polarizer

	Item	Symbol	Condition	Specification			Unit	
				Min.	Typ.	Max.		
Backlight On (Transmissive Mode)	Luminance on TFT ( $I_f=20\text{mA/LED}$ )	Lv	Normally viewing angle $\theta_x = \phi_y = 0^\circ$	560	700	-	cd/m <sup>2</sup>	
	Contrast Ratio(See 6.3)	CR		700	900	-		
	Response Time (See 6.2)	TR+TF		-	25	35	ms	
	Chromaticity Transmissive (See 6.5)	Red	XR	Center CR≥10		TBD		
			YR			TBD		
		Green	XG			TBD		
			YG			TBD		
		Blue	XB			TBD		
			YB			TBD		
	White	XW		TBD				
		YW		TBD				
	Viewing Angle (See 6.4)	Horizontal	$\theta_{x+}$		70	80	-	Deg.
$\theta_{x-}$				70	80	-		
Vertical		$\phi_{y+}$		70	80	-		
		$\phi_{y-}$		70	80	-		
NTSC Ratio(Gamut)				-	60	-	%	

6.2. Definition of Response Time

6.2.1. Normally Black Type (Negative)

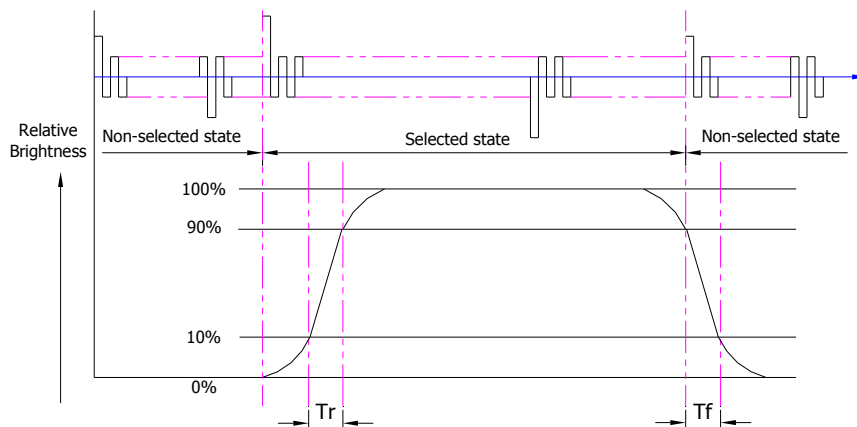

Tr is the time it takes to change from non-selected stage with relative luminance 10% to selected state with relative luminance 90%;

Tf is the time it takes to change from selected state with relative luminance 90% to non-selected state with relative luminance 10%.

Note: Measuring machine: LCD-5100

6.2.2. Normally White Type (Positive)

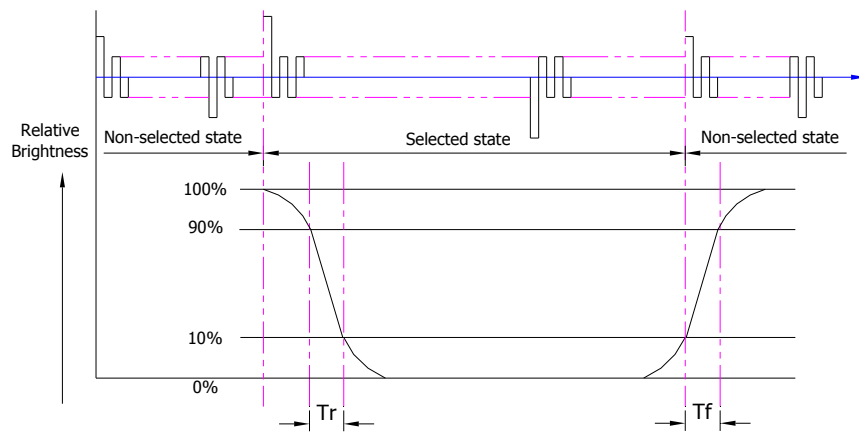

Tr is the time it takes to change from non-selected stage with relative luminance 90% to selected state with relative luminance 10%;

Tf is the time it takes to change from selected state with relative luminance 10% to non-selected state with relative luminance 90%;

Note: Measuring machine: LCD-5100 or EQUI

6.3. Definition of Contrast Ratio

Contrast is measured perpendicular to display surface in reflective and transmissive mode. The measurement condition is:

Measuring Equipment	Eldim or Equivalent
Measuring Point Diameter	3mm//1mm
Measuring Point Location	Active Area centre point
Test pattern	A: All Pixels white
	B: All Pixel black
Contrast setting	Maximum

Definitions: CR (Contrast) = Luminance of White Pixel / Luminance of Black Pixel

6.4. Definition of Viewing Angles

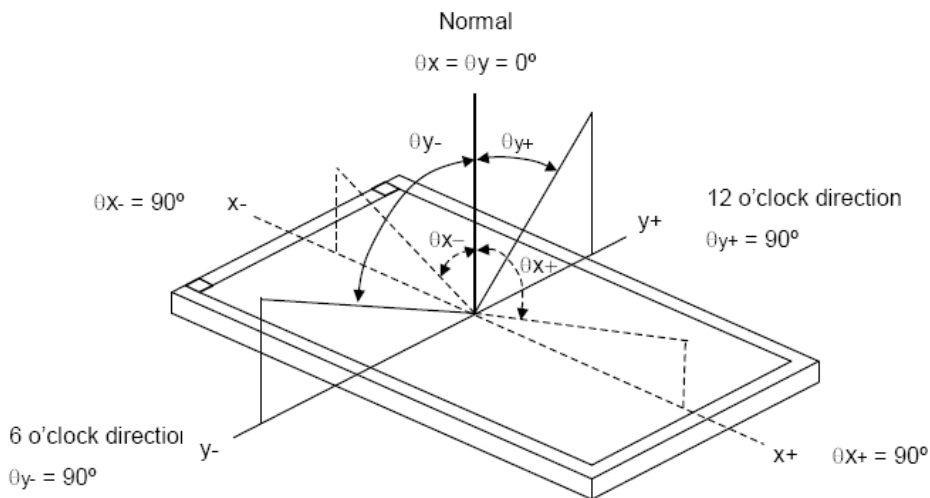

Measuring machine: LCD-5100 or EQUI

**6.5. Definition of Color Appearance**

R,G,B and W are defined by (x, y) on the IE chromaticity diagram

NTSC=area of RGB triangle/area of NTSC triangleX100%

Measuring picture: Red, Green, Blue and White (Measuring machine: BM-7)

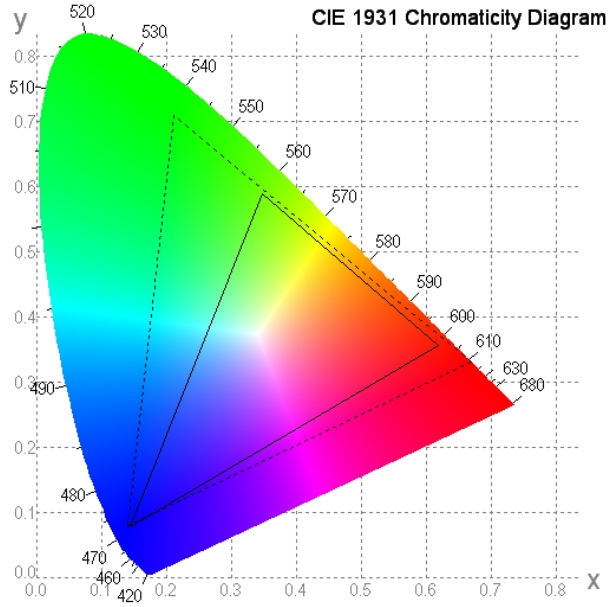

**6.6. Definition of Surface Luminance, Uniformity and Transmittance**

Using the transmissive mode measurement approach, measure the white screen luminance of the display panel and backlight.

6.6.1. Surface Luminance:  $L_v = \text{average} (L_{P1}:L_{P9})$

6.6.2. Uniformity =  $\text{Minimal} (L_{P1}:L_{P9}) / \text{Maximal} (L_{P1}:L_{P9}) * 100\%$

6.6.3. Transmittance =  $L_v \text{ on LCD} / L_v \text{ on Backlight} * 100\%$

Note: Measuring machine: BM-7

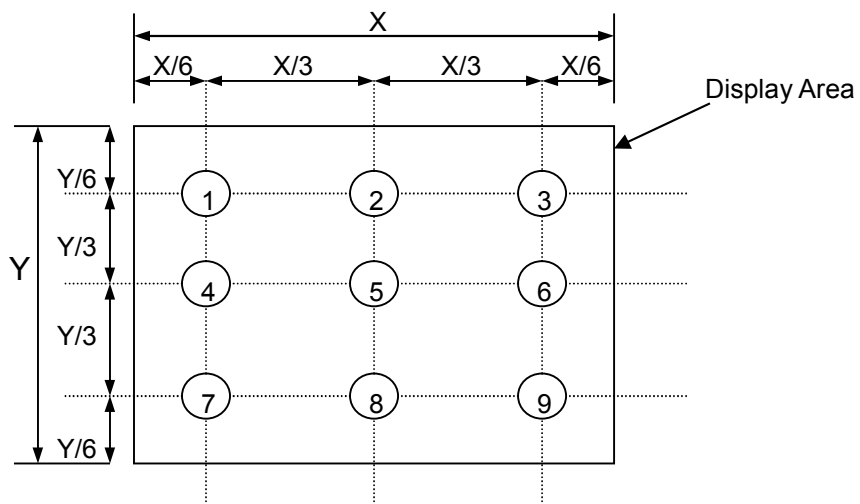



7. Block Diagram and Power Supply

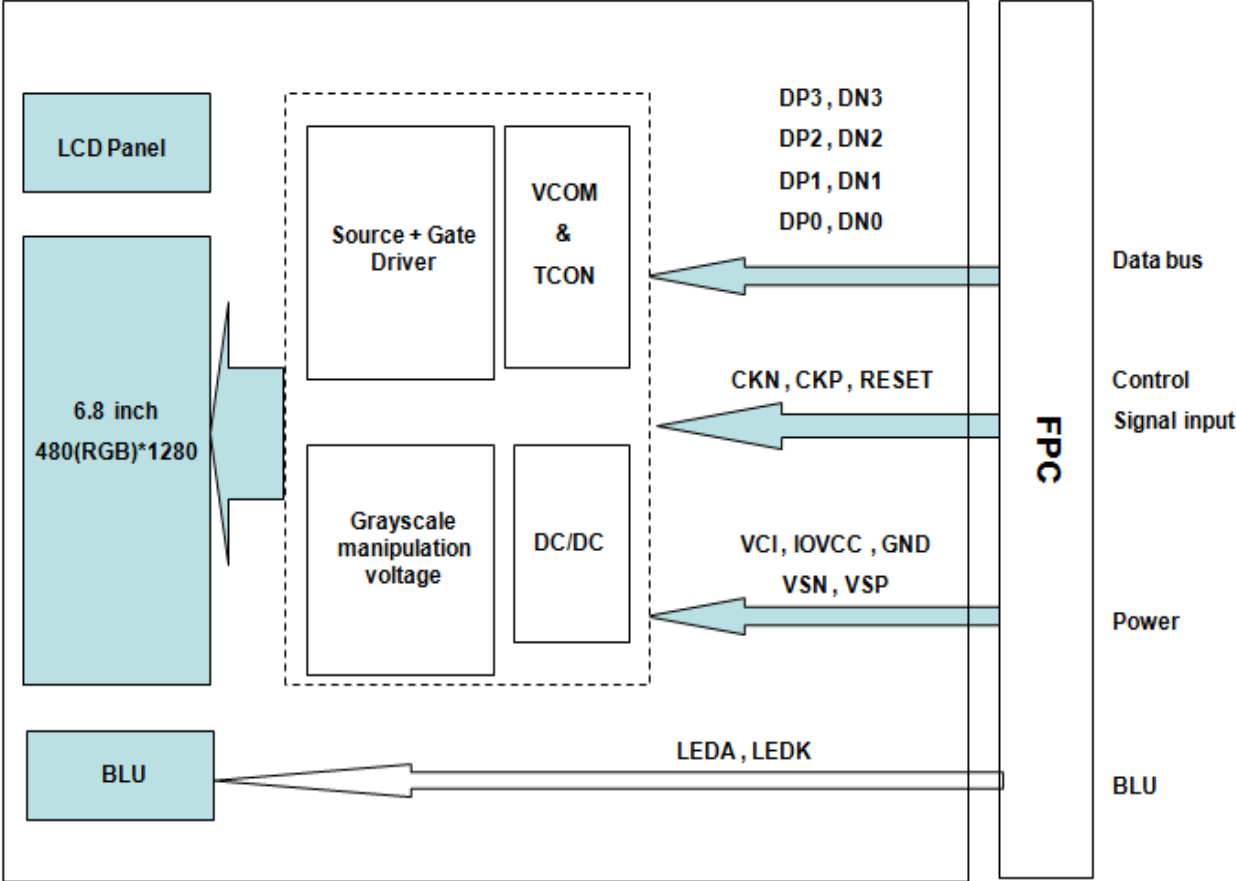

## 8. Interface Pins Definition

No.	Symbol	Function	Remark
1	GND	Ground	
2	VCI	A power supply for DC/DC circuit	
3	VCI	A power supply for DC/DC circuit	
4	IOVCC	A power supply for the I/O circuit	
5	GND	Ground	
6	RESET	Reset pin	
7	TE	No connection	
8	GND	Ground	
9	GND	Ground	
10	DN3	MIPI data Input	
11	DP3	MIPI data Input	
12	GND	Ground	
13	DN2	MIPI data Input	
14	DP2	MIPI data Input	
15	GND	Ground	
16	CKN	MIPI clock Input	
17	CKP	MIPI clock Input	
18	GND	Ground	
19	DN1	MIPI data Input	
20	DP1	MIPI data Input	
21	GND	Ground	
22	DN0	MIPI data Input	
23	DP0	MIPI data Input	
24	GND	Ground	
25	VSP	Input voltage from the set-up circuit (4.5V to 6.0V)	
26	VSN	Input voltage from the set-up circuit (-4.5V to -6.0V).	
27	LEDK	Led cathode	
28	LEDK	Led cathode	
29	LEDA	Led anode	
30	LEDA	Led anode	

## 9. AC Characteristics

### 9.1. MIPI Input timing

For 480RGBx1280

	Symbol	Value			Unit
		Min.	Typ.	Max.	
MIPI (4 Lane) @Frame rate=60Hz			386		Mbps
Lane) @Frame rate=60Hz			515		Mbps
DCLK frequency @Frame rate=60Hz	$F_{DCLK}$		64.4		MHz
HSYNC period time	$T_H$		824		DCLK
Horizontal display area	$T_{HD}$		480		DCLK
HSYNC pulse width	$T_{HPW}$		24	-	DCLK
HSYNC back porch	$T_{HBP}$		160	-	DCLK
HSYNC front porch	$T_{FBP}$		160	-	DCLK
VSYNC period time	$T_V$		1304		H
Vertical display area	$T_{VD}$		1280		H
VSYNC pulse width	$T_{VPW}$		2	-	H
VSYNC back porch	$T_{VBP}$		10	-	H
VSYNC front porch	$T_{VFP}$		12	-	H

### 9.2. MIPI AC characteristics

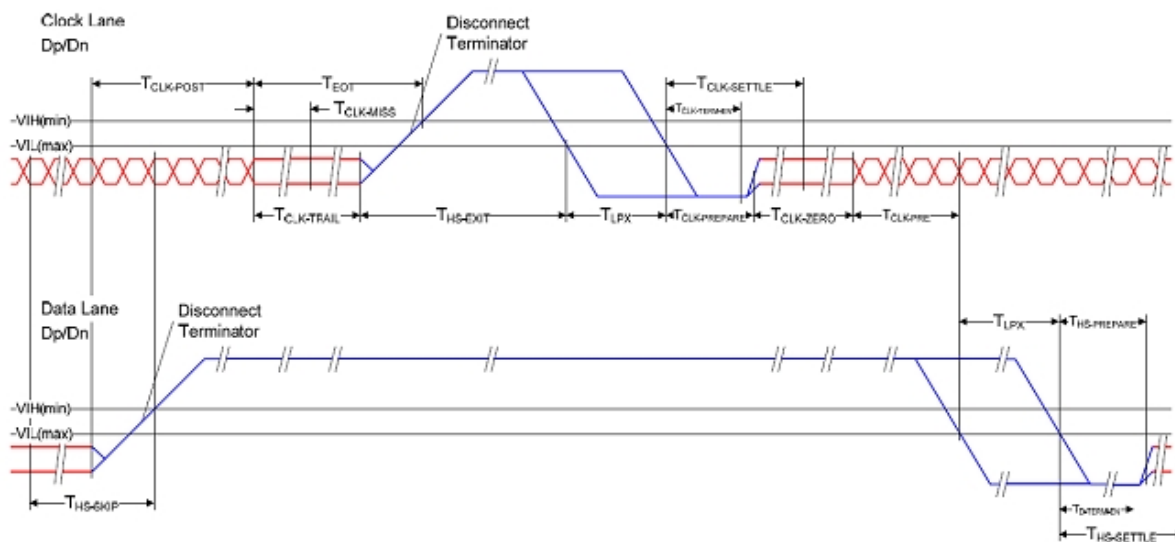

Switching the clock lane between clock transmission and low-power mode

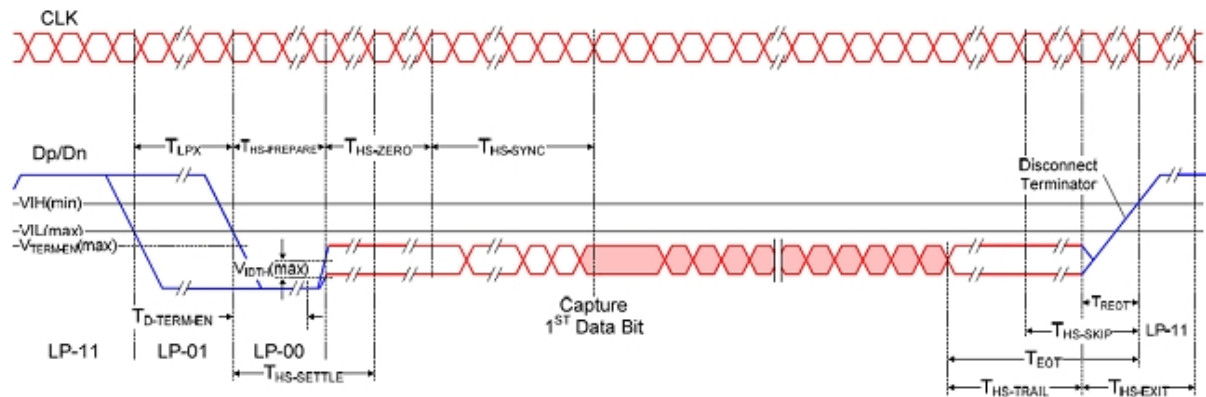

Timing of high-speed data transmission in bursts

Parameter	Descript	Spec.			Unit
		Min.	Typ.	Max.	
T <sub>RECT</sub>	30%-85% rise time and fall time	-	-	35	ns
T <sub>CLK-MISS</sub>	Timeout for receiver to detect absence of Clock transitions and disable the Clock Lane HS-RX.	-	-	60	ns
T <sub>CLK-POST</sub> *1	Time that the transmitter continues to send HS clock after the last associated Data Lane has transitioned to LP Mode. Interval is defined as the period from the end of T <sub>HS-TRAIL</sub> to the beginning of T <sub>CLK-TRAIL</sub> .	60 ns + 52*UI (For DCS)	-		ns
T <sub>CLK-PRE</sub>	Time that the HS clock shall be driven by the transmitter prior to any associated Data Lane beginning the transition from LP to HS mode.	8	-		ns
T <sub>CLK-SETTLE</sub>	Time interval during which the HS receiver shall ignore any Clock Lane HS transitions, starting from the beginning of T <sub>CLK-PRE</sub> .	95	-	300	ns
T <sub>CLK-TERM-EN</sub>	Time for the Clock Lane receiver to enable the HS line termination, starting from the time point when Dn crosses V <sub>ILMAX</sub> .	Time for Dn to reach V <sub>TERM-EN</sub>	-	38	ns
T <sub>HS-SETTLE</sub>	Time interval during which the HS receiver shall ignore any Data Lane HS transitions, starting from the beginning of T <sub>HS-SETTLE</sub> .	85 ns + 6*UI	-	145 ns + 10*UI	ns
T <sub>EOT</sub>	Time from start of T <sub>HS-TRAIL</sub> or T <sub>CLK-TRAIL</sub> period to start of LP-11 state	-	-	105ns+48*UI	-

$T_{HS-EXIT}^{(1)}$	time to drive LP-11 after HS burst	100	-	-	ns
$T_{HS-PREPARE}$	Time to drive LP-00 to prepare for HS transmission	$40ns + 4*UI$	-	$85ns+6*UI$	ns
$T_{HS-PREPARE} + T_{HS-ZERO}$	$T_{HS-PREPARE}$ + Time to drive HS-0 before the Sync sequence	$145ns + 10*UI$	-	-	ns
$T_{HS-SKIP}$	Time-out at RX to ignore transition period of EoT	40	-	$55ns+4*UI$	ns
$T_{HS-TRAIL}$	Time to drive flipped differential state after last payload data bit of a HS transmission burst	$60 + 4*UI$	-	-	ns
$T_{LPX}$	Length of any Low-Power state period	50	-	-	ns
Ratio $T_{LPX}$	Ratio of $T_{LPX(MASTER)}/T_{LPX(SLAVE)}$ between Master and Slave side	2/3	-	3/2	-
$T_{TA-GET}$	Time to drive LP-00 by new TX	$5*T_{LPX}$			ns
$T_{TA-GO}$	Time to drive LP-00 after Turnaround Request	$4*T_{LPX}$			ns
$T_{TA-SURE}$	Time-out before new TX side starts driving	$T_{LPX}$	-	$2*T_{LPX}$	ns

Note: (1) For image transmission:

$T_{CLK-POSTmin}$  value =164 when MIPI max frequency per lane = 0.53Gbps.

$T_{CLK-POSTmin}$  value =112 when MIPI max frequency per lane = 1Gbps

## 10. Reset Timing

When RESETB of the reset pin equals to Low, it will be in the condition of reset. When it is in the condition of reset, it will make the device recover the initial set.

However, in order to avoid the reset noise cause reset, there is a mechanism to judge about whether the reset is needed or not.

The closed interval of Low can be shown as the following.

(Test condition: VDDIO=1.65V~3.6V, VSS=0V,  $T_A=-20 \sim +85$ )

Parameter	Symbol	Conditions	Spec.			Unit
			Min.	Typ.	Max	
Reset low pulse width	Trst		20	-	-	$\mu s$

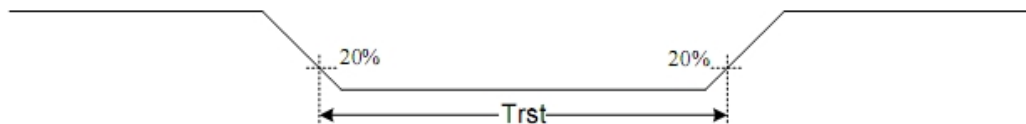

## **11. Quality Assurance**

### **11.1. Purpose**

This standard for Quality Assurance assures the quality of LCD module products supplied to customer.

### **11.2. Standard for Quality Test**

#### 11.2.1 Sampling Plan:

GB2828.1-2012

Single sampling, general inspection level II

#### 11.2.2 Sampling Criteria:

Visual inspection: AQL 1.5%

Electrical functional: AQL 0.65%.

#### 11.2.3 Reliability Test:

Detailed requirement refer to Reliability Test Specification.

### **11.3. Nonconforming Analysis & Disposition**

#### 11.3.1 Nonconforming analysis:

11.3.1.1 Customer should provide overall information of non-conforming sample for their complaints.

11.3.1.2 After receipt of detailed information from customer, the analysis of nonconforming parts usually should be finished in one week.

11.3.1.3 If cannot finish the analysis on time, customer will be notified with the progress status.

#### 11.3.2 Disposition of nonconforming:

11.3.2.1 Non-conforming product over PPM level will be replaced.

11.3.2.2 The cause of non-conformance will be analyzed. Corrective action will be discussed and implemented.

### **11.4. Agreement Items**

Shall negotiate with customer if the following situation occurs:

11.4.1 There is any discrepancy in standard of quality assurance.

11.4.2 Additional requirement to be added in product specification.

11.4.3 Any other special problem.

**11.5. Standard of the Product Visual Inspection**

11.5.1 Appearance inspection:

11.5.1.1 The inspection must be under illumination about 1000 – 1500 lx, and the distance of view must be at 30cm ± 2cm.

11.5.1.2 The viewing angle should be 45° from the vertical line without reflection light or follows customer's viewing angle specifications.

11.5.1.3 Definition of area: A Zone: Active Area, B Zone: Viewing Area,

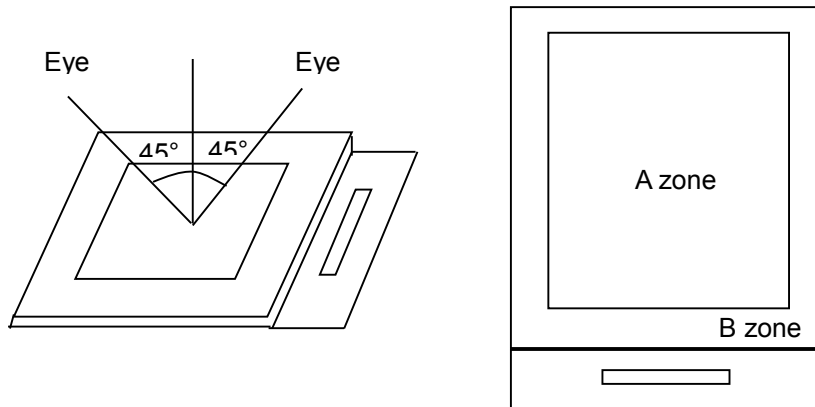

11.5.2 Basic principle:

11.5.2.1 A set of sample to indicate the limit of acceptable quality level must be discussed by both us and customer when there is any dispute happened.

11.5.2.2 New item must be added on time when it is necessary.

**11.6. Inspection Specification**

No.	Item	Criteria (Unit: mm)													
01	Black / White spot Foreign material (Round type) Pinholes Stain Particles inside cell. (Minor defect)	$\phi = (a + b) / 2$ Distance between 2 defects should more than 3mm apart.	<table border="1"> <thead> <tr> <th>Size</th> <th>Area</th> <th>Acc. Qty</th> </tr> </thead> <tbody> <tr> <td><math>\phi \leq 0.20</math></td> <td></td> <td>Ignore</td> </tr> <tr> <td><math>0.20 &lt; \phi \leq 0.50</math></td> <td></td> <td><math>N \leq 3</math></td> </tr> <tr> <td><math>0.50 &lt; \phi</math></td> <td></td> <td>0</td> </tr> </tbody> </table>	Size	Area	Acc. Qty	$\phi \leq 0.20$		Ignore	$0.20 < \phi \leq 0.50$		$N \leq 3$	$0.50 < \phi$		0
			Size	Area	Acc. Qty										
$\phi \leq 0.20$		Ignore													
$0.20 < \phi \leq 0.50$		$N \leq 3$													
$0.50 < \phi$		0													

02	Electrical Defect (Minor defect)	<table border="1"> <thead> <tr> <th></th> <th>Display Area</th> <th>Total</th> <th rowspan="3">Note1</th> </tr> </thead> <tbody> <tr> <td>Bright dot</td> <td><math>N \leq 2</math></td> <td><math>N \leq 2</math></td> </tr> <tr> <td>Dark dot</td> <td><math>N \leq 4</math></td> <td><math>N \leq 4</math></td> </tr> <tr> <td>Total dot</td> <td><math>N \leq 4</math></td> <td><math>N \leq 4</math></td> <td rowspan="2">Note 2</td> </tr> <tr> <td>Mura</td> <td colspan="2">Not visible through 5% ND filters.</td> </tr> </tbody> </table>		Display Area	Total	Note1	Bright dot	$N \leq 2$	$N \leq 2$	Dark dot	$N \leq 4$	$N \leq 4$	Total dot	$N \leq 4$	$N \leq 4$	Note 2	Mura	Not visible through 5% ND filters.	
			Display Area	Total	Note1														
		Bright dot	$N \leq 2$	$N \leq 2$															
		Dark dot	$N \leq 4$	$N \leq 4$															
Total dot	$N \leq 4$	$N \leq 4$	Note 2																
Mura	Not visible through 5% ND filters.																		
Remark:																			
1. Bright dot caused by scratch and foreign object accords to item 1.																			
03	Black and White line Scratch Foreign material (Line type) (Minor defect)																		
		<table border="1"> <thead> <tr> <th>Length</th> <th>Width</th> <th>Acc. Qty</th> </tr> </thead> <tbody> <tr> <td>/</td> <td><math>W \leq 0.03</math></td> <td>Ignore</td> </tr> <tr> <td><math>L \leq 2.5</math></td> <td><math>0.03 &lt; W \leq 0.05</math></td> <td>3</td> </tr> <tr> <td><math>L \leq 2.5</math></td> <td><math>0.05 &lt; W \leq 0.10</math></td> <td>2</td> </tr> <tr> <td>/</td> <td><math>0.1 &lt; W</math></td> <td>0</td> </tr> <tr> <td colspan="2">Total</td> <td>3</td> </tr> </tbody> </table>	Length	Width	Acc. Qty	/	$W \leq 0.03$	Ignore	$L \leq 2.5$	$0.03 < W \leq 0.05$	3	$L \leq 2.5$	$0.05 < W \leq 0.10$	2	/	$0.1 < W$	0	Total	
Length	Width	Acc. Qty																	
/	$W \leq 0.03$	Ignore																	
$L \leq 2.5$	$0.03 < W \leq 0.05$	3																	
$L \leq 2.5$	$0.05 < W \leq 0.10$	2																	
/	$0.1 < W$	0																	
Total		3																	
Distance between 2 defects should more than 3mm apart. Scratches not viewable through the back of the display are acceptable.																			
04	Glass Crack (Minor defect)																		
Crack is potential to enlarge, any type is not allowed.																			

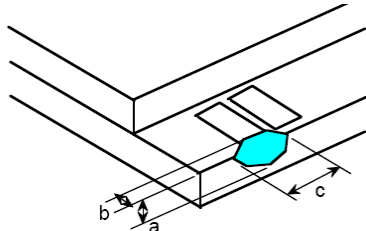
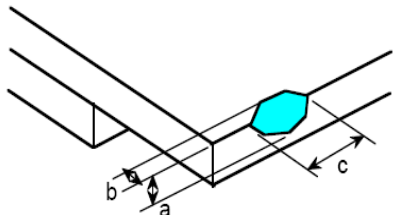
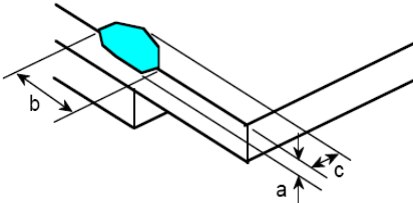
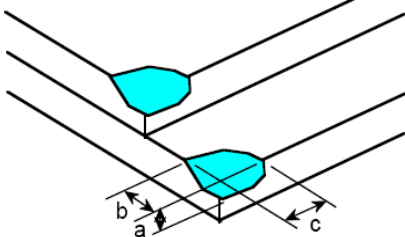

<p>05</p>	<p>Glass Chipping Pad Area: (Minor defect)</p> 	<table border="1"> <thead> <tr> <th>Length and Width</th> <th>Acc. Qty</th> </tr> </thead> <tbody> <tr> <td><math>c &gt; 3.0, b &lt; 1.0</math></td> <td>1</td> </tr> <tr> <td><math>c &lt; 3.0, b &lt; 1.0</math></td> <td>3</td> </tr> <tr> <td colspan="2"><math>a &lt; \text{Glass Thickness}</math></td> </tr> </tbody> </table>	Length and Width	Acc. Qty	$c > 3.0, b < 1.0$	1	$c < 3.0, b < 1.0$	3	$a < \text{Glass Thickness}$			
Length and Width	Acc. Qty											
$c > 3.0, b < 1.0$	1											
$c < 3.0, b < 1.0$	3											
$a < \text{Glass Thickness}$												
<p>06</p>	<p>Glass Chipping Rear of Pad Area: (Minor defect)</p> 	<table border="1"> <thead> <tr> <th>Length and Width</th> <th>Acc. Qty</th> </tr> </thead> <tbody> <tr> <td><math>c &gt; 3.0, b &lt; 1.0</math></td> <td>1</td> </tr> <tr> <td><math>c &lt; 3.0, b &lt; 1.0</math></td> <td>2</td> </tr> <tr> <td><math>c &lt; 3.0, b &lt; 0.5</math></td> <td>4</td> </tr> <tr> <td colspan="2"><math>a &lt; \text{Glass Thickness}</math></td> </tr> </tbody> </table>	Length and Width	Acc. Qty	$c > 3.0, b < 1.0$	1	$c < 3.0, b < 1.0$	2	$c < 3.0, b < 0.5$	4	$a < \text{Glass Thickness}$	
Length and Width	Acc. Qty											
$c > 3.0, b < 1.0$	1											
$c < 3.0, b < 1.0$	2											
$c < 3.0, b < 0.5$	4											
$a < \text{Glass Thickness}$												
<p>07</p>	<p>Glass Chipping Except Pad Area: (Minor defect)</p> 	<table border="1"> <thead> <tr> <th>Length and Width</th> <th>Acc. Qty</th> </tr> </thead> <tbody> <tr> <td><math>c &gt; 3.0, b &lt; 1.0</math></td> <td>1</td> </tr> <tr> <td><math>c &lt; 3.0, b &lt; 1.0</math></td> <td>2</td> </tr> <tr> <td><math>c &lt; 3.0, b &lt; 0.5</math></td> <td>4</td> </tr> <tr> <td colspan="2"><math>a &lt; \text{Glass Thickness}</math></td> </tr> </tbody> </table>	Length and Width	Acc. Qty	$c > 3.0, b < 1.0$	1	$c < 3.0, b < 1.0$	2	$c < 3.0, b < 0.5$	4	$a < \text{Glass Thickness}$	
Length and Width	Acc. Qty											
$c > 3.0, b < 1.0$	1											
$c < 3.0, b < 1.0$	2											
$c < 3.0, b < 0.5$	4											
$a < \text{Glass Thickness}$												
<p>08</p>	<p>Glass Corner Chipping: (Minor defect)</p> 	<table border="1"> <thead> <tr> <th>Length and Width</th> <th>Acc. Qty</th> </tr> </thead> <tbody> <tr> <td><math>c &lt; 3.0, b &lt; 3.0</math></td> <td>Ignore</td> </tr> <tr> <td colspan="2"><math>a &lt; \text{Glass Thickness}</math></td> </tr> </tbody> </table>	Length and Width	Acc. Qty	$c < 3.0, b < 3.0$	Ignore	$a < \text{Glass Thickness}$					
Length and Width	Acc. Qty											
$c < 3.0, b < 3.0$	Ignore											
$a < \text{Glass Thickness}$												

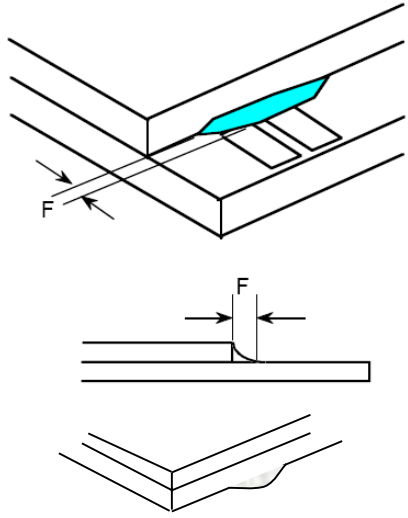
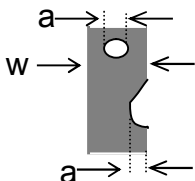
<p>09</p>	<p>Glass Burr: (Minor defect)</p> 	<table border="1" data-bbox="853 264 1324 353"> <thead> <tr> <th>Length</th> <th>Acc. Qty</th> </tr> </thead> <tbody> <tr> <td>F &lt; 1.0</td> <td>Ignore</td> </tr> </tbody> </table> <p>Glass burr don't affect assemble and module dimension.</p>	Length	Acc. Qty	F < 1.0	Ignore						
Length	Acc. Qty											
F < 1.0	Ignore											
<p>10</p>	<p>FPC Defect: (Minor defect)</p> 	<p>10.1 Dent, pinhole width <math>a &lt; w/3</math>. (w: circuitry width.)</p> <p>10.2 Open circuit is unacceptable.</p> <p>10.3 No oxidation, contamination and distortion.</p>										
<p>11</p>	<p>Bubble on Polarizer (Minor defect)</p>	<table border="1" data-bbox="726 1339 1197 1554"> <thead> <tr> <th>Diameter</th> <th>Acc. Qty</th> </tr> </thead> <tbody> <tr> <td><math>\varphi \leq 0.20</math></td> <td>Ignore</td> </tr> <tr> <td><math>0.20 &lt; \varphi \leq 0.30</math></td> <td>4</td> </tr> <tr> <td><math>0.30 &lt; \varphi \leq 0.50</math></td> <td>1</td> </tr> <tr> <td><math>0.50 &lt; \varphi</math></td> <td>None</td> </tr> </tbody> </table>	Diameter	Acc. Qty	$\varphi \leq 0.20$	Ignore	$0.20 < \varphi \leq 0.30$	4	$0.30 < \varphi \leq 0.50$	1	$0.50 < \varphi$	None
Diameter	Acc. Qty											
$\varphi \leq 0.20$	Ignore											
$0.20 < \varphi \leq 0.30$	4											
$0.30 < \varphi \leq 0.50$	1											
$0.50 < \varphi$	None											
<p>12</p>	<p>Dent on Polarizer (Minor defect)</p>	<table border="1" data-bbox="726 1615 1197 1830"> <thead> <tr> <th>Diameter</th> <th>Acc. Qty</th> </tr> </thead> <tbody> <tr> <td><math>\varphi \leq 0.20</math></td> <td>Ignore</td> </tr> <tr> <td><math>0.20 &lt; \varphi \leq 0.30</math></td> <td>4</td> </tr> <tr> <td><math>0.30 &lt; \varphi \leq 0.50</math></td> <td>1</td> </tr> <tr> <td><math>0.50 &lt; \varphi</math></td> <td>None</td> </tr> </tbody> </table>	Diameter	Acc. Qty	$\varphi \leq 0.20$	Ignore	$0.20 < \varphi \leq 0.30$	4	$0.30 < \varphi \leq 0.50$	1	$0.50 < \varphi$	None
Diameter	Acc. Qty											
$\varphi \leq 0.20$	Ignore											
$0.20 < \varphi \leq 0.30$	4											
$0.30 < \varphi \leq 0.50$	1											
$0.50 < \varphi$	None											
<p>13</p>	<p>Bezel</p>	<p>13.1 No rust, distortion on the Bezel.</p> <p>13.2 No visible fingerprints, stains or other contamination.</p>										

14	Touch Panel	<p>D: Diameter W: width L: length</p> <p>14.1 Spot: <math>D &lt; 0.25</math> is acceptable  <math>0.25 \leq D \leq 0.4</math></p> <p>2dots are acceptable and the distance between defects should more than 10 mm.</p> <p><math>D &gt; 0.4</math> is unacceptable</p> <p>14.2 Dent: <math>D &gt; 0.40</math> is unacceptable</p> <p>14.3 Scratch: <math>W \leq 0.03</math>, <math>L \leq 10</math> is acceptable,  <math>0.03 &lt; W \leq 0.10</math>, <math>L \leq 10</math> is acceptable</p> <p>Distance between 2 defects should more than 10 mm.  <math>W &gt; 0.10</math> is unacceptable.</p>
15	PCB	<p>15.1 No distortion or contamination on PCB terminals.</p> <p>15.2 All components on PCB must same as documented on the BOM/component layout.</p> <p>15.3 Follow IPC-A-600F.</p>
16	Soldering	Follow IPC-A-610C standard
17	Electrical Defect (Major defect)	<p>The below defects must be rejected.</p> <p>17.1 Missing vertical / horizontal segment,</p> <p>17.2 Abnormal Display.</p> <p>17.3 No function or no display.</p> <p>17.4 Current exceeds product specifications.</p> <p>17.5 LCD viewing angle defect.</p> <p>17.6 No Backlight.</p> <p>17.7 Dark Backlight.</p> <p>17.8 Touch Panel no function.</p>

Remark: LCD Panel Broken shall be rejected. Defect out of LCD viewing area is acceptable.

**11.7. Classification of Defects**

- 11.7.1 Visual defects (Except no / wrong label) are treated as minor defect and electrical defect is major.
- 11.7.2 Two minor defects are equal to one major in lot sampling inspection.

**11.8. Identification/marketing criteria**

Any unit with illegible / wrong /double or no marking/ label shall be rejected.

**11.9. Packaging**

- 11.9.1 There should be no damage of the outside carton box, each packaging box should have one identical label.
- 11.9.2 Modules inside package box should have compliant mark.
- 11.9.3 All direct package materials shall offer ESD protection

**Note1:** Bright dot is defined as the defective area of the dot is larger than 50% of one sub-pixel area.

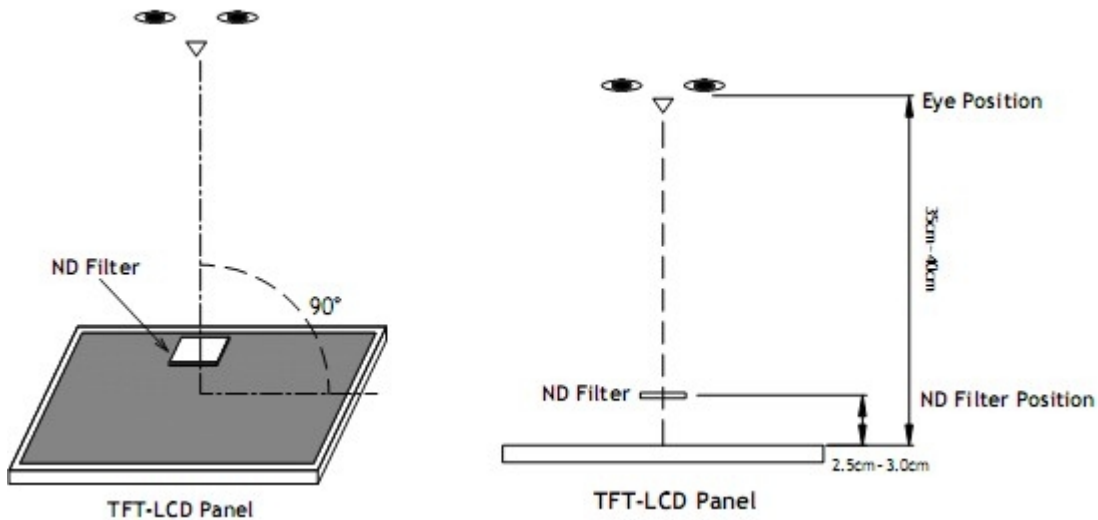

Bright dot: The bright dot size defect at black display pattern. It can be recognized by 2% transparency of filter when the distance between eyes and panel is 350mm±50mm.

Dark dot: Cyan, Magenta or Yellow dot size defect at white display pattern. It can be recognized by 5% transparency of filter when the distance between eyes and panel is 350mm±50mm.

**Note2:** Mura on display which appears darker / brighter against background brightness on parts of display area.

### 12. Reliability Specification

No	Item	Condition	Quantity	Criteria
1	High Temperature Operating	60°C, 96Hrs	2	GB/T2423.2-2008
2	Low Temperature Operating	-20°C, 96Hrs	2	GB/T2423.1-2008
3	High Humidity	40°C, 90%RH, 96Hrs	2	GB/T2423.3-2006
4	High Temperature Storage	65°C, 96Hrs	2	GB/T2423.2-2008
5	Low Temperature Storage	-20°C, 96Hrs	2	GB/T2423.1-2008
6	Thermal Cycling Test	-20°C, 60min ~ 60°C, 60min, 20 cycles.	2	GB/T2423.22-2012
7	Packing vibration	Frequency range:10Hz~50Hz Acceleration of gravity:5G X, Y, Z 30 min for each direction.	2	GB/T5170.14-2009
8	Electrical Static Discharge	Air: ±4KV 150pF/330Ω 5 times	2	GB/T17626.2-2006
		Contact: ±2KV 150pF/330Ω 5 times		
9	Drop Test (Packaged)	Height:80 cm,1 corner, 3 edges, 6 surfaces.	2	GB/T2423.8-1995

Note1. No deflection cosmetic and operational function allowable.

Note2. Total current Consumption should be below double of initial value

**13. Precautions and Warranty**

**13.1 Safety**

- 13.1.1. The liquid crystal in the LCD is poisonous. Do not put it in your mouth. If the liquid crystal touches your skin or clothes, wash it off immediately using soap and water.
- 13.1.2. Since the liquid crystal cells are made of glass, do not apply strong impact on them. Handle with care.

**13.2. Handling**

- 13.2.1. Reverse and use within ratings in order to keep performance and prevent damage.
- 13.2.2. Do not wipe the polarizer with dry cloth, as it might cause scratch. If the surface of the LCD needs to be cleaned, wipe it swiftly with cotton or other soft cloth soaked with petroleum IPA, do not use other chemicals.

**13.3. Storage**

- 13.3.1 Do not store the LCD module beyond the specified temperature ranges.

**13.4. Metal Pin (Apply to Products with Metal Pins)**

13.4.1. Pins of LCD and Backlight

- 13.4.1.1. Solder tip can touch and press on the tip of Pin LEAD during the soldering

13.4.1.2. Recommended Soldering Conditions

Solder Type: Sn96.3~94-Ag3.3~4.3-Cu0.4~1.1

Maximum Solder Temperature: 370°C

Maximum Solder Time: 3s at the maximum temperature

Recommended Soldering Temp: 350±20°C

Typical Soldering Time: ≤3s

13.4.1.3. Solder Wetting

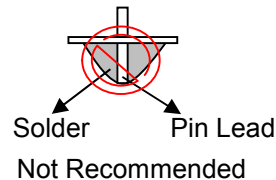
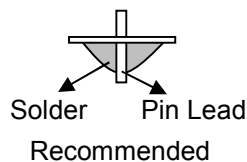

13.4.2. Pins of EL

- 13.4.2.1. Solder tip can touch and press on the tip of EL leads during soldering.

- 13.4.2.2. No Solder Paste on the soldering pad on the motherboard is recommended.

13.4.2.3. Recommended Soldering Conditions

Solder type: Nippon Alimit Leadfree SR-34, size 0.5mm

Recommended Solder Temperature: 270°C~290°C

Typical Soldering Time: ≤2s

Minimum solder distance from EL lamp (body):2.0mm

- 13.4.2.4. No horizontal press on the EL leads during soldering.

- 13.4.2.5. 180° bend EL leads three times is not allowed.

13.4.2.6. Solder Wetting

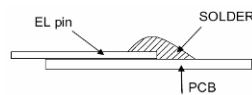

Recommended

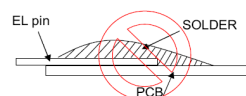

Not Recommended

13.4.2.7. The type of the solder iron:

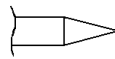

Recommended

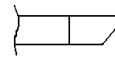

Not Recommended

13.4.2.8. Solder Pad

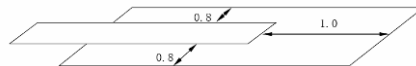

**13.5. Operation**

- 13.5.1. Do not drive LCD with DC voltage
- 13.5.2. Response time will increase below lower temperature
- 13.5.3. Display may change color with different temperature
- 13.5.4. Mechanical disturbance during operation, such as pressing on the display area, may cause the segments to appear “fractured”.

**13.6. Static Electricity**

- 13.6.1. CMOS LSIs are equipped in this unit, so care must be taken to avoid the electro-static charge, by ground human body, etc.
- 13.6.2. The normal static prevention measures should be observed for work clothes and benches.
- 13.6.3. The module should be kept into anti-static bags or other containers resistant to static for storage.

**13.7. Limited Warranty**

- 13.7.1. Our warranty liability is limited to repair and/or replacement. We will not be responsible for any consequential loss.
- 13.7.2. If possible, we suggest customer to use up all modules in six months. If the module storage time over twelve months, we suggest that recheck it before the module be used.
- 13.7.3. After the product shipped, any product quality issues must be feedback within three months, otherwise, we will not be responsible for the subsequent or consequential events.

14. Packaging

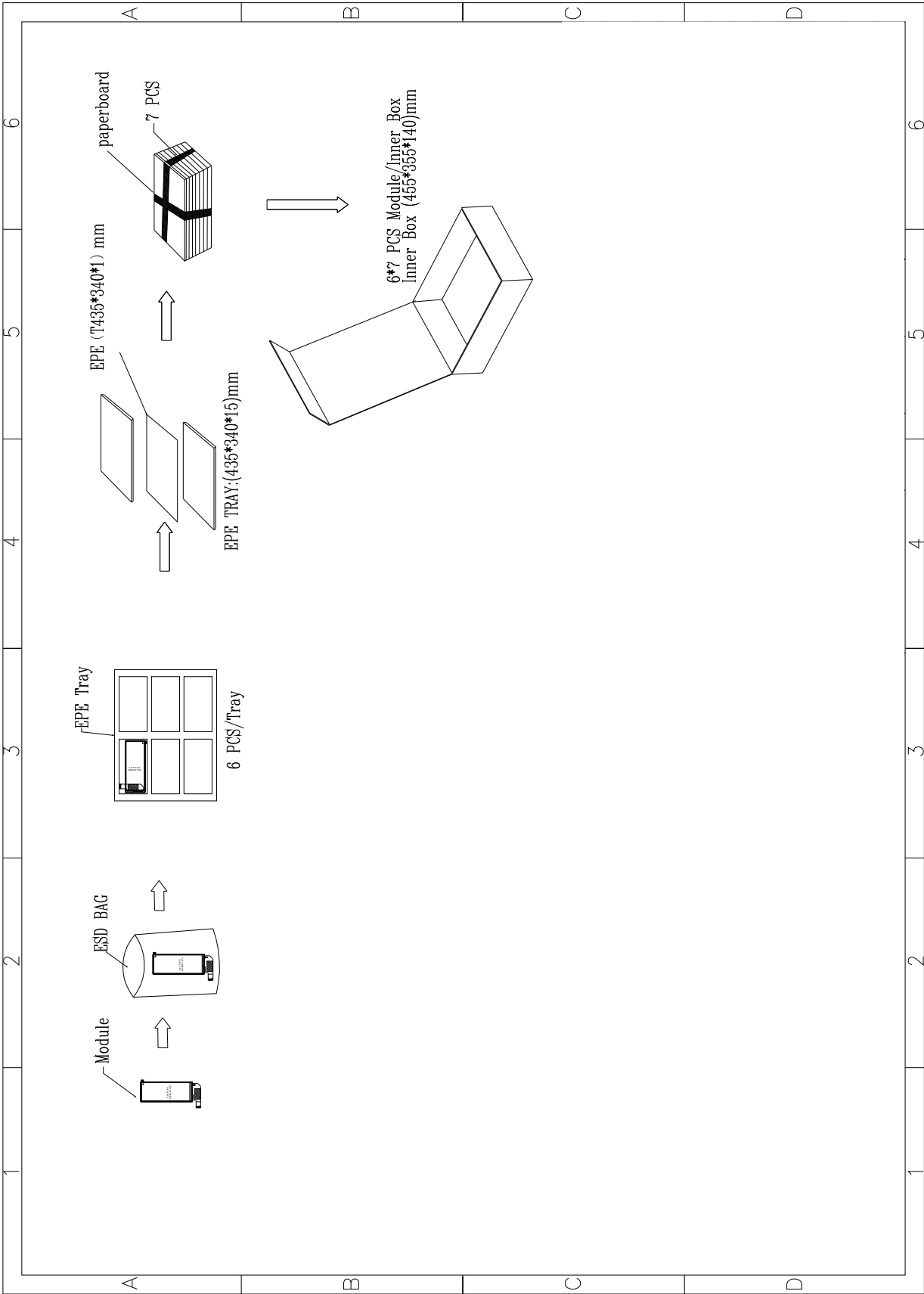

15. Outline Drawing

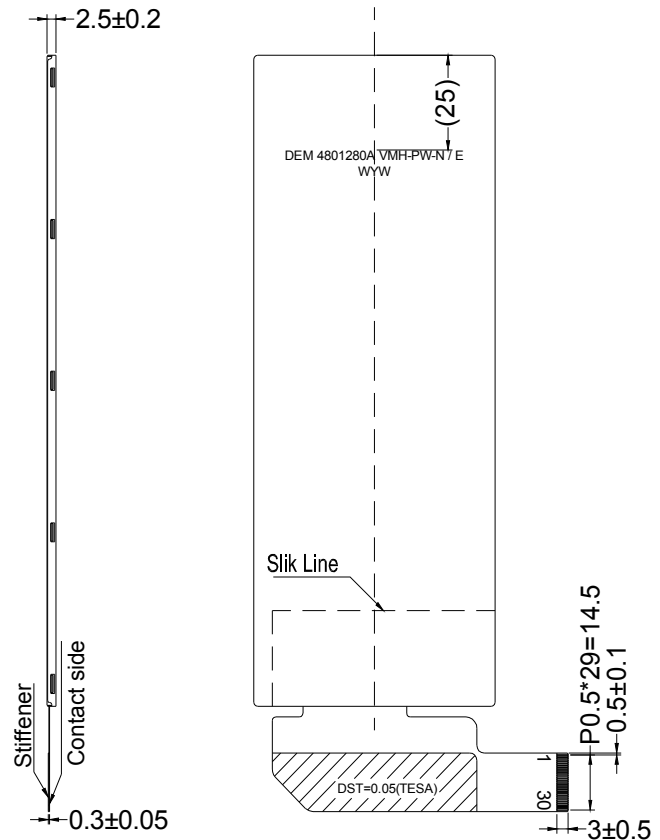
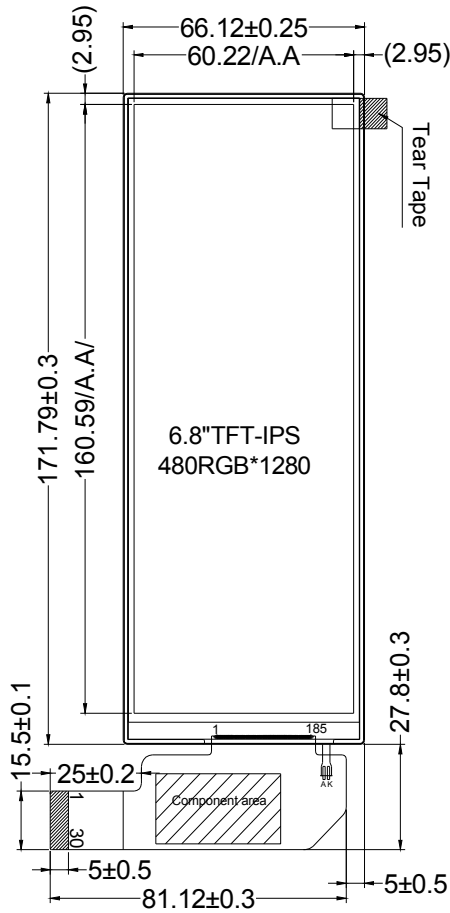

NOTES:

1. Display size: 6.8" TFT
  2. Viewing direction: FULL VIEW/IPS
  3. Display mode: Transmissive/Normal Black
  4. Operation temperature: -20°C~+60°C
  5. Storage temperature: -20°C~+65°C
  6. Driver IC: EK79030
  7. Power supply voltage: 3.3V
  8. Backlight : White(12 LED)/12V(TYP)/120mA
  9. ROHS must be complied
- \* Unspecification tolerance are ±0.2mm

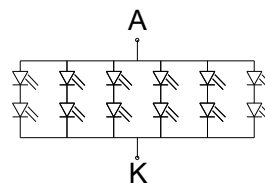

Circuit Diagram:  
Double Core Lamp

PIN FUNCTION

PIN	SYMBOL
1	GND
2	VCI
3	VCI
4	IOVCC
5	GND
6	RESET
7	TE
8	GND
9	GND
10	DN3
11	DP3
12	GND
13	DN2
14	DP2
15	GND
16	CKN
17	CKP
18	GND
19	DN1
20	DP1
21	GND
22	DN0
23	DP0
24	GND
25	VSP
26	VSN
27	LEDK
28	LEDK
29	LEDA
30	LEDA