

DISPLAY Elektronik GmbH

DATA SHEET

LCD MODULE

DEM 9509 TGH-LY

Product specification

Version : 3

13/October/2006

GENERAL SPECIFICATION

MODULE NO. :

DEM 9509 TGH-LY

CUSTOMER P/N

VERSION NO.	CHANGE DESCRIPTION	DATE
0	ORIGINAL VERSION	25/01/2001
1	CHANGED MODULE DRAWING	30/10/2001
2	ADD VERSION	16/07/2005
3	CHANGED MODULE NAME	13/10/2006

PREPARED BY: HZZ DA TE: 13/10/2006

APPROVED BY: MH DATE: 13/10/2006

CONTENTS

1. DESCRIPTION ----- 2

2. FUNCTIONS & FEATURES ----- 2

3. OPERATING SPECIFICATIONS ----- 2

4. BLOCK DIAGRAM ----- 2

5. EXTERNAL DIMENSIONS ----- 3

6. DEFINITION OF TERMINALS ----- 3

7. PCB DRAWING AND DESCRIPTION ----- 4

8. BACKLIGHT ----- 5

9. DISPLAY PATTERN ----- 6

10. DISPLAY RAM ADDRESS AND DISPLAY DIGIT POSITION ----- 6

11. ELECTRICAL CHARACTERISTICS ----- 7

12. DECODED DISPLAY RAM DATA ----- 8

13. INSTRUCTION SET ----- 9

14. LCD MODULES HANDLING PRECAUTIONS ----- 10

15. OTHERS ----- 10

1. DESCRIPTION

DEM 9509 is a 8-character, 14-segment intelligent module designed to communicate with microprocessor through serial interface.

2. FUNCTIONS & FEATURES

MODULE NAME	LCD TYPE
DEM 9509 TGH-LY	TN Transflective Positive Mode

- Viewing Direction : 6 o'clock
- Driving Scheme : 1/4 Duty Cycle, 1/3 Bias
- Backlight Color : Yellow-Green, Lightbox
- VLCD (VDD-V0) : 4.5 Volt (typ.)
- Low power consumption CMOS technology.
- Built-in 14-segment ASCII alphanumeric decoder.
- Two 32x4 static RAM for display data and blinding data storage.
- An intelligent quadruples driver display module.
- +5V single power supply.
- Serial interface.

3. OPERATING SPECIFICATIONS

- Operating Temperature : -10°C to +70°C
- Storage Temperature : -30°C to +85°C

4. BLOCK DIAGRAM

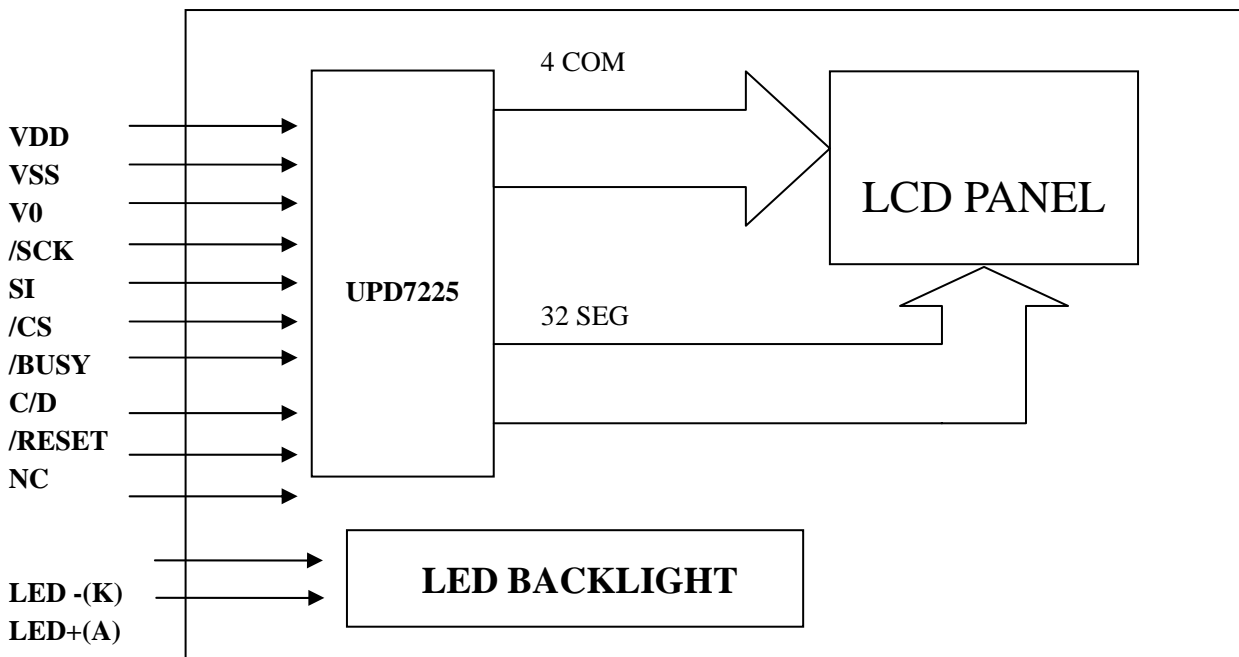

5. EXTERNAL DIMENSIONS

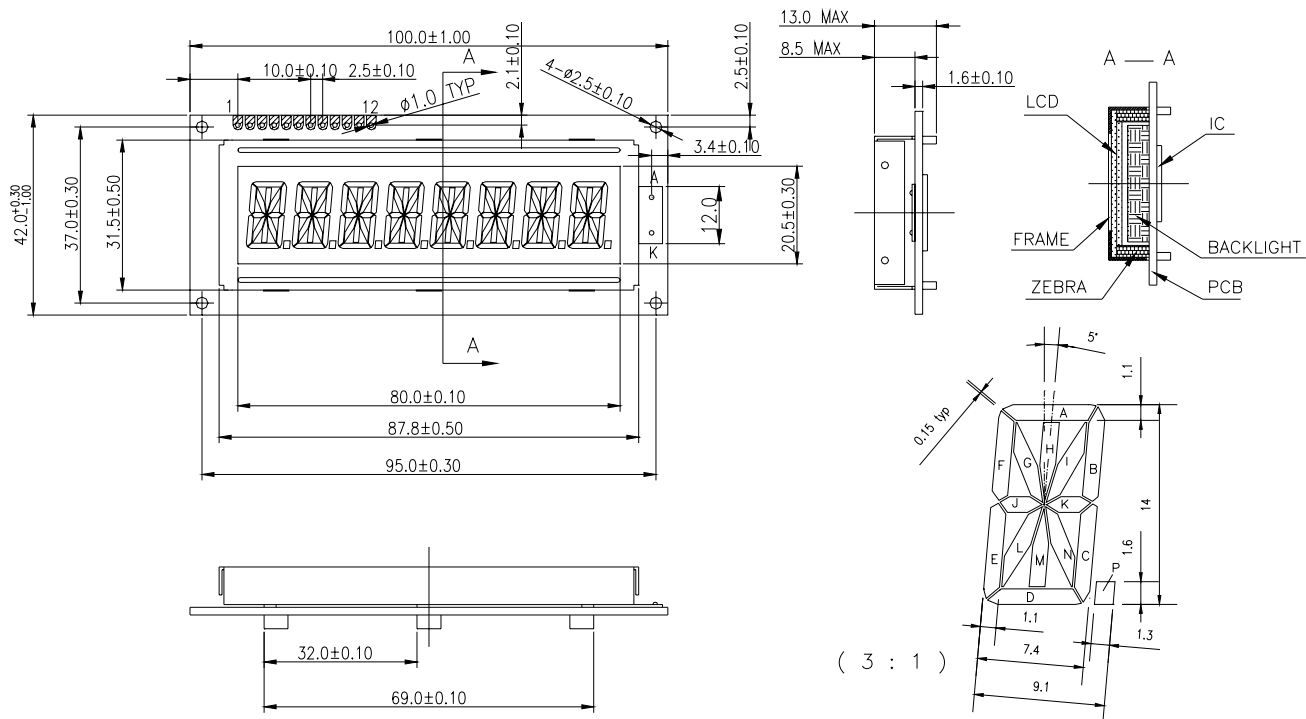

6. DEFINITION OF TERMINALS

Pin No.	Symbol	Description	
1	VSS	Ground terminal	
2	VDD	Supply terminal	
3	V	0	LCD driving voltage
4	/SCK		Serial clock input
5	SI		Serial input
6	/CS		Chip select input
7	/BU	SY	Busy output
8	C/D		Command/Data select
9	/RESET		Reset input
10	N	C	No connection
11	LED -		Please also refer to 7-1
12	LED +		Please also refer to 7-1

7. PCB DRAWING AND DESCRIPTION

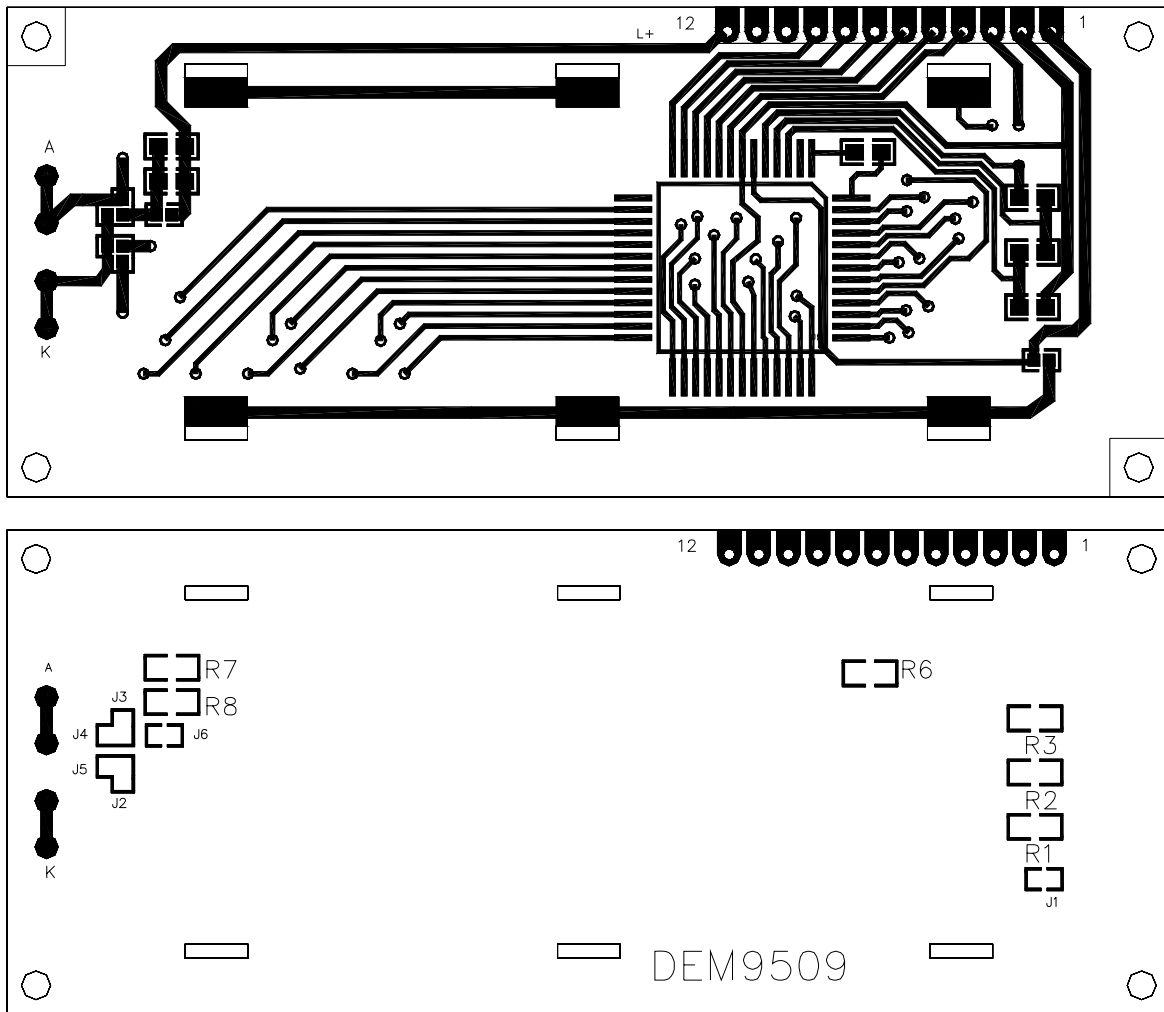

7-1. DESCRIPTION

1) The polarity of the pin 11 and the pin 12

Symbol S	Symbol	LED Polarity	
		11PIN	12PIN
J2,J4	Each Solder-Bridge	Anode	Cathode
J3,J5	Each Solder-Bridge	Cathode	Anode

※NOTE: In application module: J3=J5=Closed, J2=J4=Open

2) The metal-bezel is set on ground when the J1 is closed.

※ Note: in application module, J1=Closed

3) The LED Resistor can be bridged when the J6 is closed

※ Note: in application module, J6=Open

4) The R7,R8 is the LED Resistor.

※ Note: in application module, R8=10 Ohm and R7=Open

7-2. EXAMPLE APPLICATION:

7-2-1. The LED resistor should be bridged as following.

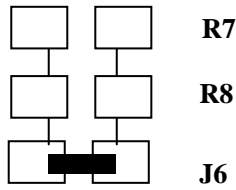

7-2-2. The 11 pin is the Anode and the 12 pin is the Cathode as following.

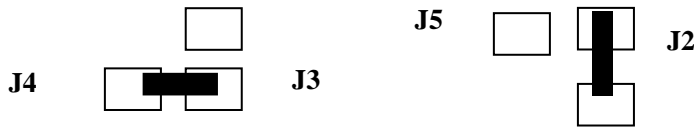

7-2-3. The 11 pin is the cathode and the 12 pin is the anode as following.

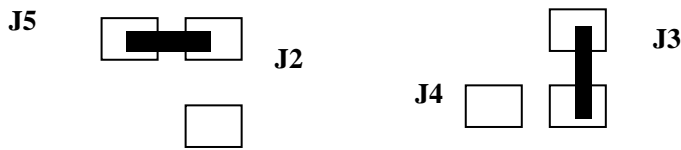

7-2-4. The metal-bezel is ground as following.



8. BACKLIGHT

ITEM	SYMBOL	STANDARD VALUE	UNIT	APPLICABLE TERMINAL
Backlight Voltage	V	5	V	LED+ / LED-
Backlight Current	I	~ 81	mA	

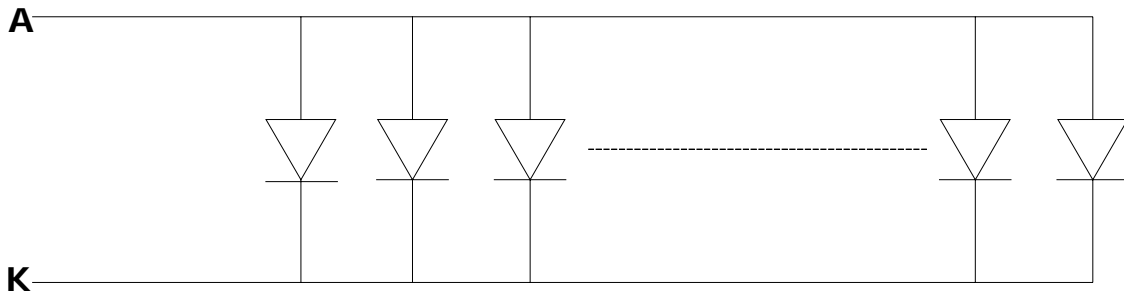

9. DISPLAY PATTERN

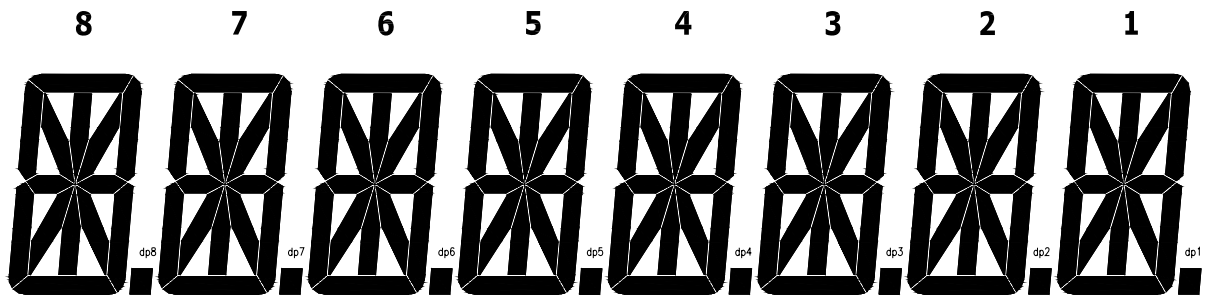

10. DISPLAY RAM ADDRESS AND DISPLAY DIGIT POSITION

display RAM addressed BIT	0	1	2	3	4	5	6	7	8	9	10	11	12	13	14	15	16	17	18	19	20	21	22	23	24	25	26	27	28	29	30	31
0	1h	1a	1g	2h	2a	2g	3h	3a	3g	4h	4a	4g	5h	5a	5g	6h	6a	6g	7h	7a	7g	8h	8a	8g								
1	1i	1f	1b	1j	2i	2f	2b	2j	3i	3f	3b	3j	4i	4f	4b	4j	5i	5f	5b	5j	6i	6f	6b	6j	7i	7f	7b	7j	8i	8f	8b	8j
2	1k	1e	1c	1l	2k	2e	2c	2l	3k	3e	3c	3l	4k	4e	4c	4l	5k	5e	5c	5l	6k	6e	6c	6l	7k	7e	7c	7l	8k	8e	8c	8l
3	1n	1d	dp1	1m	2n	2d	dp2	2m	3n	3d	dp3	3m	4n	4d	dp4	4m	5n	5d	dp5	5m	6n	6d	dp6	6m	7n	7d	dp7	7m	8n	8d	dp8	8m

11. ELECTRICAL CHARACTERISTICS (Ta = +25°C, Vdd = 5V)

PARAMETER	SYMBOL	CONDITION	MIN	TYP	MAX	UNIT
Supply voltage	V _{DD}	3.0		5.0	5	V
Current consumption	I _{DD}			200		uA
Input high voltage	V _{IH}	0	.7V _{DD}	V _{DD}		V
Input low voltage	V _{IL}	0		0	.3V _{DD}	V
Output high voltage	V _{OH}	Output current=-10uA	V _{DD} -0.5			V
Output low voltage	V _{OL}	Output current=100uA		0.5		V
Power supply for LCD drive	V _{DD-V0}	Ta=0°C		4.7		V
		Ta=25°C		4.5		
		Ta=50°C		4.0		
SCK cycle	T _{CYK}	90	0			ns
SCK high pulse width	T _{WHK}	40	0			ns
SCK low pulse width	T _{WLK}	40	0			ns
SI set-up time to SCK	T _{ISK}	10	0			ns
SI hold time after to SCK	T _{IHK}	20	0			ns
C/D set-up time to 8th,SCK	T _{DSK}	9				us
C/D hold time after 8th, SCK	T _{DHK}	1				us
CS hold time after 8th, SCK	T _{CHK}	1				us
CS pulse width low	T _{CWL}	40				us
CS pulse width high	T _{CWH}	40				us

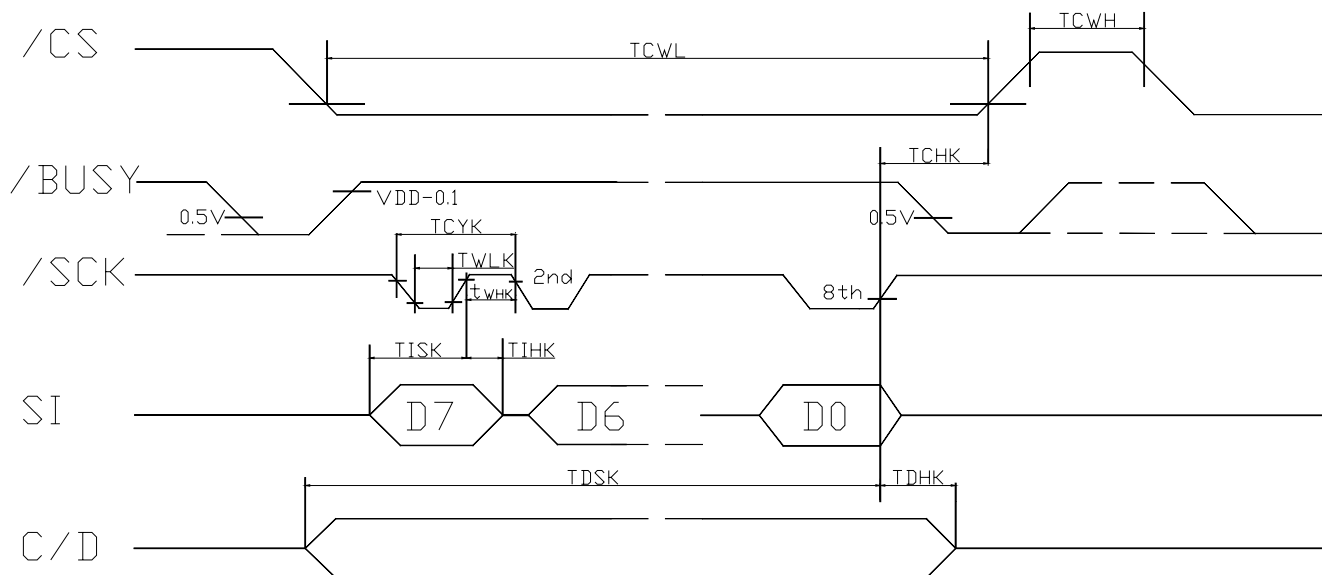

12. DECODED DISPLAY RAM DATA

14-segment alphanumeric data decoder character set

Display byte (hex)	A			B			C			D						
	Char	Display RAM address			Char	Display RAM address			Char	Display RAM address			Char	Display RAM address		
		N-3	N-2	N+1 N		N-3	N-2	N+1 N		N-3	N-2	N+1 N		N-3	N-2	N+1 N
0		0	0	00		4	7	E 2		A	7	C 0		2	3	6 4
1		Invalid				0	6	0 0		2	7	6 4		0	7	E 8
2		Invalid				2	3	C 4		8	7	8 5		2	3	6 C
3		Invalid				2	7	8 4		0	1	E 0		1	5	8 4
4		Invalid				2	6	2 4		8	7	8 1		8	1	0 1
5		Invalid				2	5	A 4		2	1	E 4		0	6	E 0
6		Invalid				2	5	E 4		2	1	6 4		4	0	6 2
7		0	0	02		0	7	0 0		0	5	E 4		4	6	6 8
8		0	0	0A		2	7	E 4		2	6	6 4		5	0	0 A
9		5	0	00		2	7	A 4		8	1	8 1		9	0	0 2
A		F	0	0F		Invalid				0	6	C 0		4	1	8 2
B		A	0	05		Invalid				2	0	6 A		Invalid		
C		Invalid				4	0	8 2		0	0	E 0		1	0	0 8
D		2	0	04		2	0	8 4		1	6	6 2		Invalid		
E		Invalid				1	0	8 8		1	6	6 8		Invalid		
F		4	0	02		Invalid				0	7	E 0		Invalid		

13. INSTRUCTION SET

COMMAND	DESCRIPTION	INSTRUCTION								HEX	
		D7	D6	D5	D4	D3	D2	D1	D0		
MODE SET	Initialize the up D7225 1) LCD drive configuration 2) LCD bias voltage configuration 3) LCD frame frequency	0	1	0	0	0	0	1		0	42
UNSYNCHRONOUS DATA TRANSFER	Synchronize display RAM data transfer to display latch with CS	0	0	1	1	0	0	0		0	30
SYNCHRONOUS DATA TRANSFER	Synchronize display RAM data transfer to display latch with LCD drive cycle	0	0	1	1	0	0	0		1	31
INTERRUPT DATA TRANSFER	Interrupt display RAM data transfer to display	0	0	1	1	1	0	0		0	38
LOAD DATA POINTER	Load data pointer with 5 bits of immediate data	1	1	1	D4	D3	D2	D1	D0		E0~FF
CLEAR DISPLAY RAM	Clear the display RAM and reset the data pointer	0	0	1	0	0	0	0		0	20
WRITE DISPLAY RAM	Write 4-bits of immediate data to the display RAM location addressed by the data pointer. Increment data pointer	1	1	0	1	D3	D2	D1	D0		D0~DF
AND DISPLAY RAM	Perform logical and between the display RAM data addressed by the data pointer and 4-bits of immediate data write result to same display RAM location. Increment data pointer	1	0	0	1	D3	D2	D1	D0		90~9F
OR DISPLAY RAM	Perform logical or between the display RAM data addressed by the data pointer and 4-bits of immediate data write result to same display RAM location. Increment data pointer.	1	0	1	1	D3	D2	D1	D0		B0~BF
ENABLE SEGMENT DECODER	Start use of the segment decoder	0	0	0	1	0	1	0		1	15
DISABLE SEGMENT DECODER	Stop use of the segment decoder	0	0	0	1	0	1	0		0	14
ENABLE DISPLAY	Turn on the LCD	0	0	0	1	0	0	0		1	11
DISABLE DISPLAY	Turn off the LCD	0	0	0	1	0	0	0		0	10
CLEAR BLINKING RAM	Clear the blinking RAM and reset the data pointer	0	0	0	0	0	0	0		0	00
WRITE BLINKING RAM	Write 4-bits of immediate data to the blinking RAM location addressed by the data pointer. Increment data pointer.	1	1	0	0	D3	D2	D1	D0		C0~CF
AND BLINKING RAM	Perform logical and between the blinking RAM data addressed by the data pointer and 4-bits of immediate data write result to same blinking RAM location. Increment data pointer.	1	0	0	0	D3	D2	D1	D0		80~8F
OR BLINKING RAM	Perform logical or between the blinking RAM data addressed by the data pointer and 4-bits of immediate data write result to same blinking RAM location. Increment data pointer.	1	0	1	0	D3	D2	D1	D0		A0~AF
ENABLE BLINKING	Start segment blinking at the frequency specified by 1 bits of immediate data.	0	0	0	1	1	0	1		D0	1A~1B
DISABLE BLINKING	Stop segment blinking	0	0	0	1	1	0	0	0		18

14. LCD MODULES HANDLING PRECAUTIONS

- Please remove the protection foil of polarizer before using.
- The display panel is made of glass. Do not subject it to a mechanical shock by dropping it from a high place, etc.
- If the display panel is damaged and the liquid crystal substance inside it leaks out, do not get any in your mouth. If the substance comes into contact with your skin or clothes promptly wash it off using soap and water.
- Do not apply excessive force to the display surface or the adjoining areas since this may cause the color tone to vary.
- The polarizer covering the display surface of the LCD module is soft and easily scratched. Handle this polarizer carefully.
- To prevent destruction of the elements by static electricity, be careful to maintain an optimum work environment.
 - Be sure to ground the body when handling the LCD module.
 - Tools required for assembly, such as soldering irons, must be properly grounded.
 - To reduce the amount of static electricity generated, do not conduct assembly and other work under dry conditions.
 - The LCD module is coated with a film to protect the display surface. Exercise care when peeling off this protective film since static electricity may be generated.
- Storage precautions
When storing the LCD modules, avoid exposure to direct sunlight or to the light of fluorescent lamps. Keep the modules in bags designed to prevent static electricity charging under low temperature / normal humidity conditions (avoid high temperature / high humidity and low temperatures below 0°C). Whenever possible, the LCD modules should be stored in the same conditions in which they were shipped from our company.

15. OTHERS

- Liquid crystals solidify at low temperature (below the storage temperature range) leading to defective orientation of liquid crystal or the generation of air bubbles (black or white). Air bubbles may also be generated if the module is subjected to a strong shock at a low temperature.
- If the LCD modules have been operating for a long time showing the same display patterns may remain on the screen as ghost images and a slight contrast irregularity may also appear. Abnormal operating status can be resumed to be normal condition by suspending use for some time. It should be noted that this phenomena does not adversely affect performance reliability.
- To minimize the performance degradation of the LCD modules resulting from caused by static electricity, etc. exercise care to avoid holding the following sections when handling the modules:
 - Exposed area of the printed circuit board
 - Terminal electrode sections