

# LIQUID CRYSTAL DISPLAY MODULE

## Product Specification

<b>CUSTOMER</b>	
<b>CUSTOMER PART NUMBER</b>	
<b>PRODUCT NUMBER</b>	<b>DET020CFNCNT0-1A</b>

Product Mgr	Design Eng
<b>Bruno Recaldini</b>	<b>Luo Luo</b>
Date: 17-Feb-15	Date: 17-Feb-15

## TABLE OF CONTENTS

<b>1</b>	<b>MAIN FEATURES</b> .....	<b>4</b>
<b>2</b>	<b>MECHANICAL SPECIFICATION</b> .....	<b>5</b>
2.1	MECHANICAL CHARACTERISTICS.....	5
2.2	MECHANICAL DRAWING.....	6
<b>3</b>	<b>ELECTRICAL SPECIFICATION</b> .....	<b>7</b>
3.1	ABSOLUTE MAXIMUM RATINGS.....	7
3.2	ELECTRICAL CHARACTERISTICS.....	7
3.3	INTERFACE PIN ASSIGNMENT .....	8
3.4	BLOCK DIAGRAM .....	9
3.5	TIMING CHARACTERISTICS .....	10
3.6	POWER SEQUENCE .....	12
<b>4</b>	<b>OPTICAL SPECIFICATION</b> .....	<b>13</b>
4.1	OPTICAL CHARACTERISTICS .....	13
<b>5</b>	<b>BACKLIGHT SPECIFICATION</b> .....	<b>15</b>
5.1	LED DRIVING CONDITIONS .....	15
5.2	LED CIRCUIT .....	15
<b>6</b>	<b>QUALITY ASSURANCE SPECIFICATION</b> .....	<b>16</b>
6.1	DELIVERY INSPECTION STANDARDS .....	16
6.2	DEALING WITH CUSTOMER COMPLAINTS.....	22
<b>7</b>	<b>RELIABILITY SPECIFICATION</b> .....	<b>23</b>
7.1	RELIABILITY TESTS.....	23
<b>8</b>	<b>HANDLING PRECAUTIONS</b> .....	<b>24</b>

**REVISION RECORD**

<b>Rev.</b>	<b>Date</b>	<b>Page</b>	<b>Chapt.</b>	<b>Comment</b>	<b>ECN no.</b>
1.0	17-Feb-15			First Issue	

## 1 MAIN FEATURES

ITEM	CONTENTS
Screen Size	2.0" Diagonal
Display Format	176 x RGB x 220 Dots
N° of Colour	65K
Overall Dimensions	38.4 mm (H) x 51.4 mm (V) x 2.35 mm (D)
Active Area	31.68 mm (H) x 39.6 mm (V)
LCD Type	TFT
Mode	Transmissive / Normally White
Viewing Direction	Full view
Interface	8 bit MPU (8080)
Driver IC	ST7775R
Backlight Type	LED
Operating Temperature	-20°C ~ +70°C
Storage Temperature	-30°C ~ +80°C
RoHS compliant	Yes

## 2 MECHANICAL SPECIFICATION

### 2.1 MECHANICAL CHARACTERISTICS

---

ITEM	CHARACTERISTIC	UNIT
Display Format	176 x RGB x 220 Dots	Dots
Overall Dimensions	38.4 mm (H) x 51.4 mm (V) x 2.35 mm (D)	mm
Viewing Area	33.3 (H) x 41.2 (V)	mm
Active Area	31.68 mm (H) x 39.6 mm (V)	mm
Pixel Pitch	0.18 (H) x 0.18 (V)	mm
Weight	6 typ	g

## 2.2 MECHANICAL DRAWING

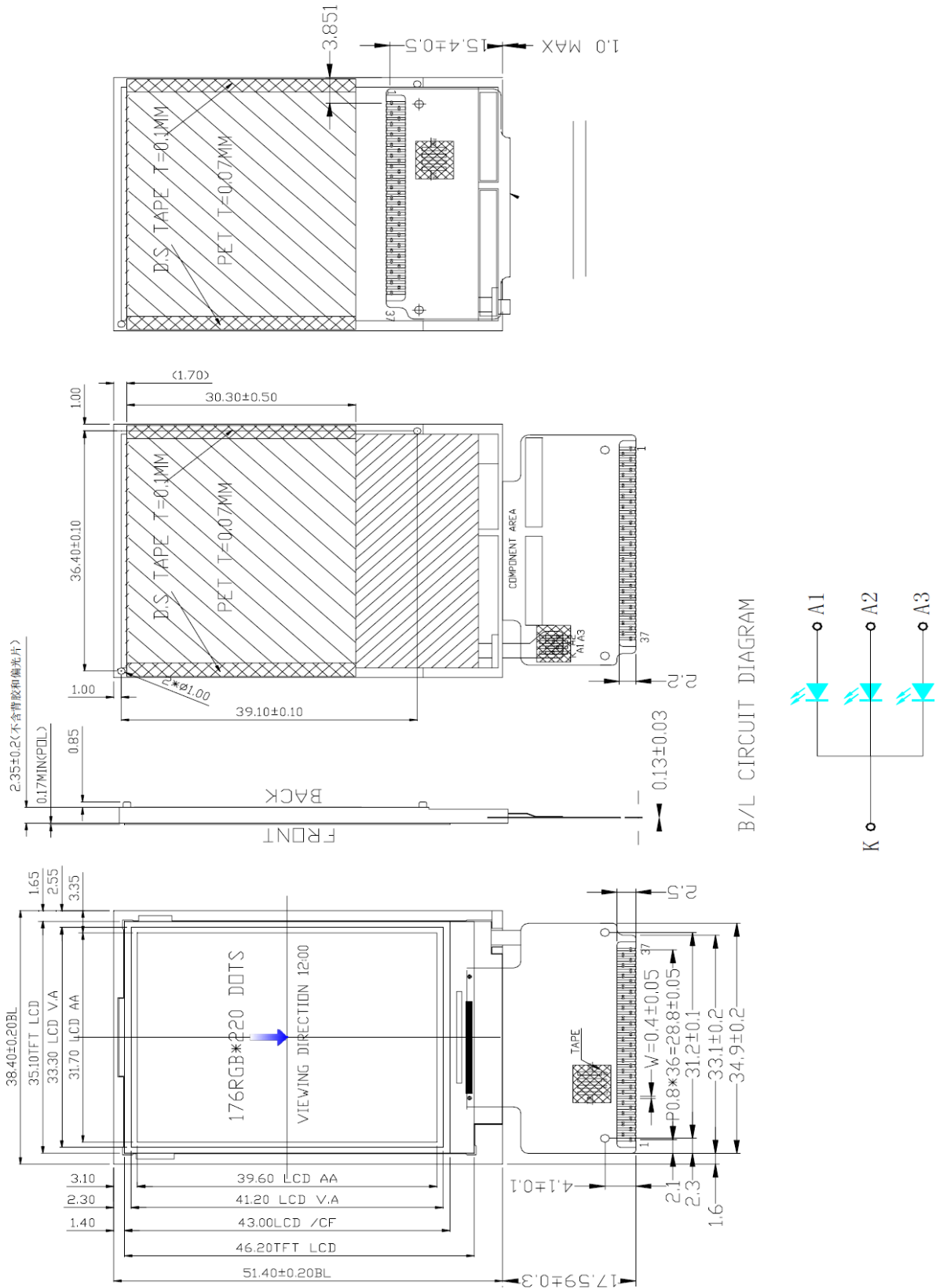

Product No.	DET020CFNCNT0-1A	REV. 1.0
-------------	------------------	----------

Page	6 / 24
------	--------

### 3 ELECTRICAL SPECIFICATION

#### 3.1 ABSOLUTE MAXIMUM RATINGS

Item	Symbol	Condition	Min	Max	Unit	Note
Power Supply Voltage	VCCIO, VCC	Ta=25°C	-0.3	4.6	V	
Operating Temperature	TOP		-20	70	°C	1
Storage Temperature	TST		-30	80	°C	1,2,3

Note 1. 90 % RH Max for Ta<50 °C, and 60% RH for Ta≥50°C.

Note 2. In case of below 0°C, the response time of liquid crystal (LC) becomes slower and the colour of panel becomes darker than normal one. Level of retardation depends on temperature, because of LC's characteristic.

Note 3. Only operation is guaranteed at operating temperature. Contrast, response time, another display quality are evaluated at +25°C.

#### 3.2 ELECTRICAL CHARACTERISTICS

Item	Symbol	Condition	Min	Typ	Max	Unit	Note
Supply Voltage	VCC		2.5	2.8	3.3	V	
Supply Voltage	VCCIO		1.65	1.8	3.3	V	
Input Voltage for Logic	VIH		0.8xVCCIO	-	VCCIO	V	
	VIL		0	-	0.3xVCCIO	V	
Output Voltage for Logic	VOH		0.8xVCCIO	-	VCC	V	
	VOL		0	-	0.2xVCCIO	V	
Current Consumption	ICC		-	2.5		mA	1

Note 1: The specified power consumption is under the conditions of VCC=VCCIO=2.8V, FV=60Hz, whereas Power dissipation check pattern below is displayed.

Black pattern

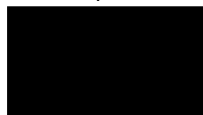

Active Area

### 3.3 INTERFACE PIN ASSIGNMENT

#### 3.3.1 LCM PIN ASSIGNMENT

Pin No.	Symbol	Function
1	GND	Ground
2	NC	No connection
3	RESET	Reset device and must be applied to properly initialize the chip
4-11	NC	No connection
12-19	DB0-DB7	Data bus
20	RD (RDX)	Read enable. If not used, please connect this pin to VCC
21	WR (WRX)	Write enable in parallel interface
22	RS (DCX)	Display data/Command selection pin
23	CS (CSX)	Chip select input pin ("Low" enable). This pin can be permanently fixed "Low" in MCU interface mode only.
24	VCC	Power supply voltage
25	GND	Ground
26	VCCIO	Supply voltage for IO
27	NC	No connection
28	NC (XR)	No connection (reserved for touch panel)
29	NC (YD)	No connection (reserved for touch panel)
30	NC (XL)	No connection (reserved for touch panel)
31	NC (YU)	No connection (reserved for touch panel)
32	GND	Ground
33	LEDA1	Anode pin of backlight
34	LEDA2	Anode pin of backlight
35	LEDA3	Anode pin of backlight
36	NC	No connection
37	LEDK	LED Cathode pin of backlight



### 3.4 BLOCK DIAGRAM

---

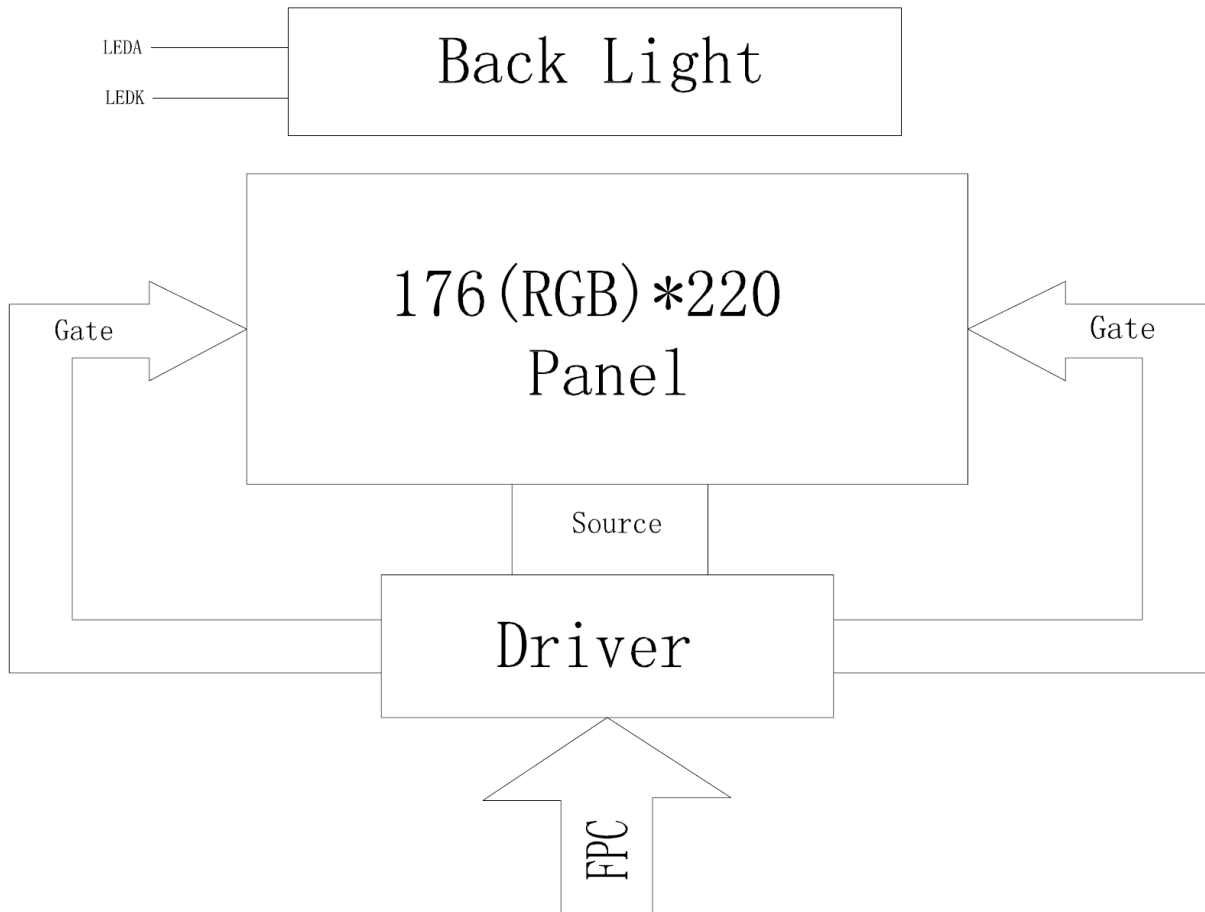

### 3.5 TIMING CHARACTERISTICS

Please refer to driver IC ST7775R datasheet for more information

#### 3.5.1 Parallel MPU 8-bit interface 8080-series

Item	Symbol	MIN	MAX	Unit	Remark	
Address setup time	RS (DCX)	tast	10	-	Ns	
Address hold time (Write/Read)		taht	5	-	ns	
Write cycle	WR (WRX)	Twc	70	-	ns	
Write Control pulse H duration		Twrh	35	-	ns	
Write Control pulse L duration		twrl	35	-	ns	
Read cycle (ID)	RD [RDX (ID)]	trc	300	-	ns	When read ID data
Read Control H duration		trdh	150	-	ns	
Read Control L duration		trdl	150	-	ns	
Write data setup time	D[17:0]	tdst	10	-	ns	TRAR, TRATFM:3k ohm Pull up or Down and 30 pF Parallel Cap. To GND. TODH:3k ohm Pull up or Down
Write data hold time		tdht	15	-	ns	
Read access time (ID)		trat	-	100	ns	
Output disable time		todh	50	-	ns	

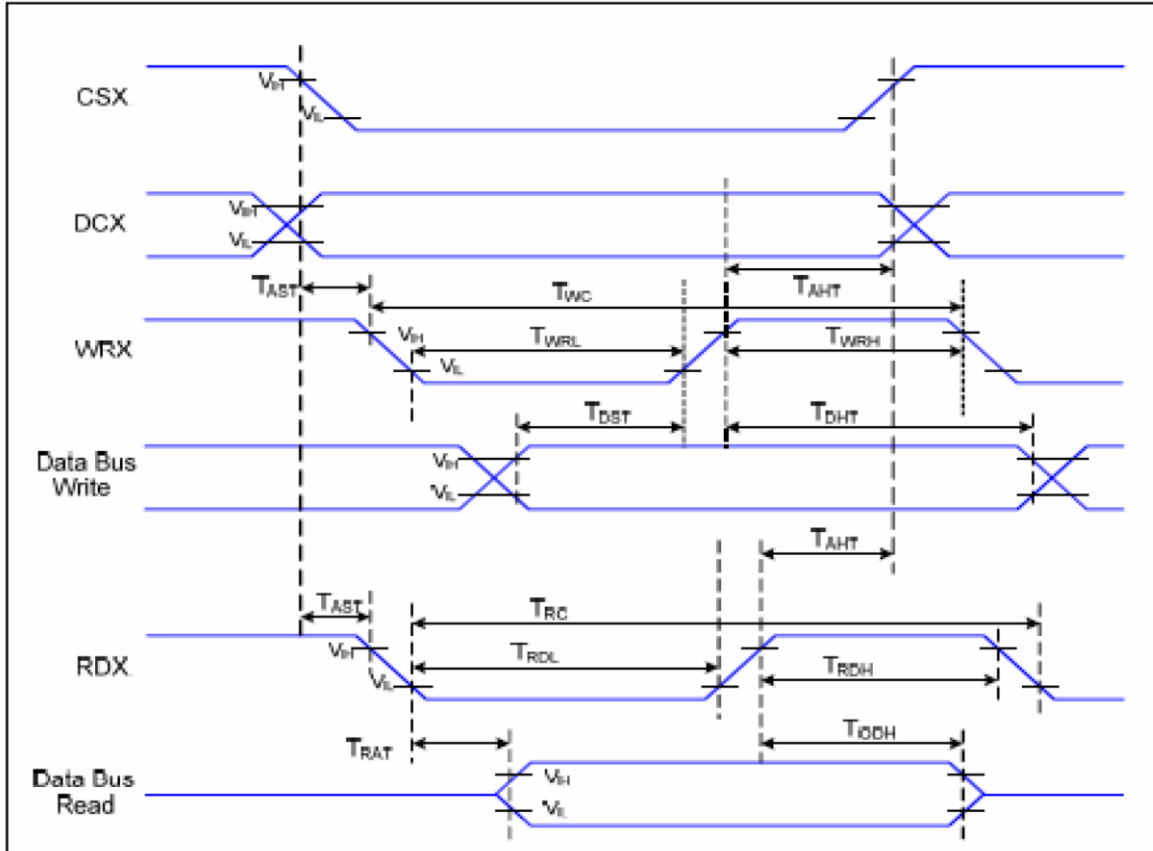

Figure 1 Parallel interface 8080-series Timing Characteristics

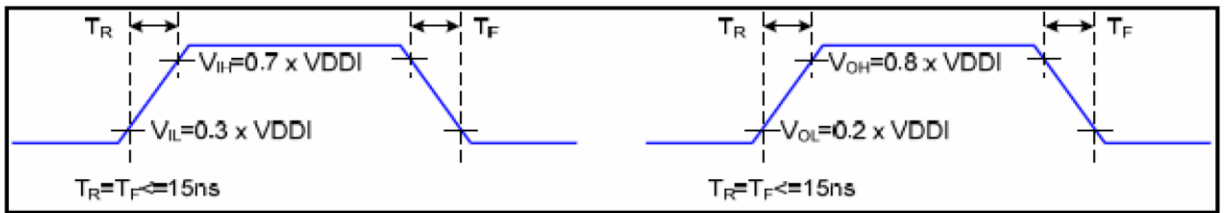

Figure 2 Rising and Falling Timing for I/O Signal

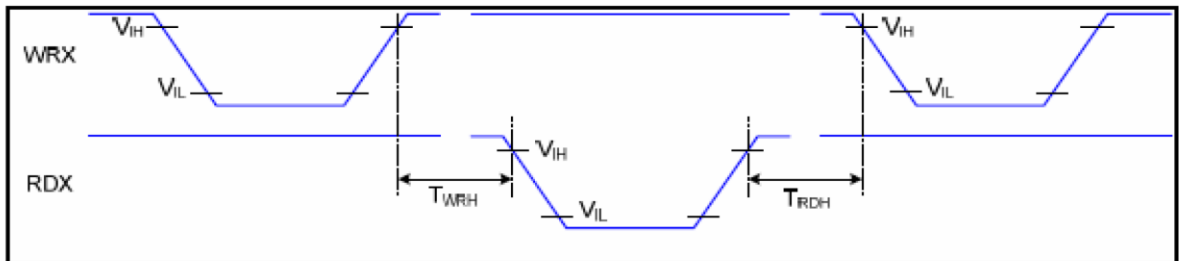
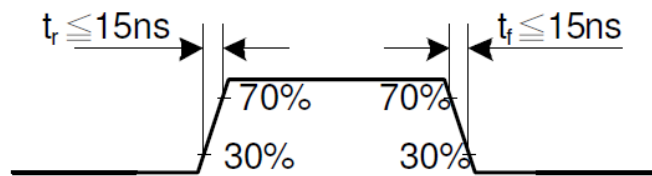
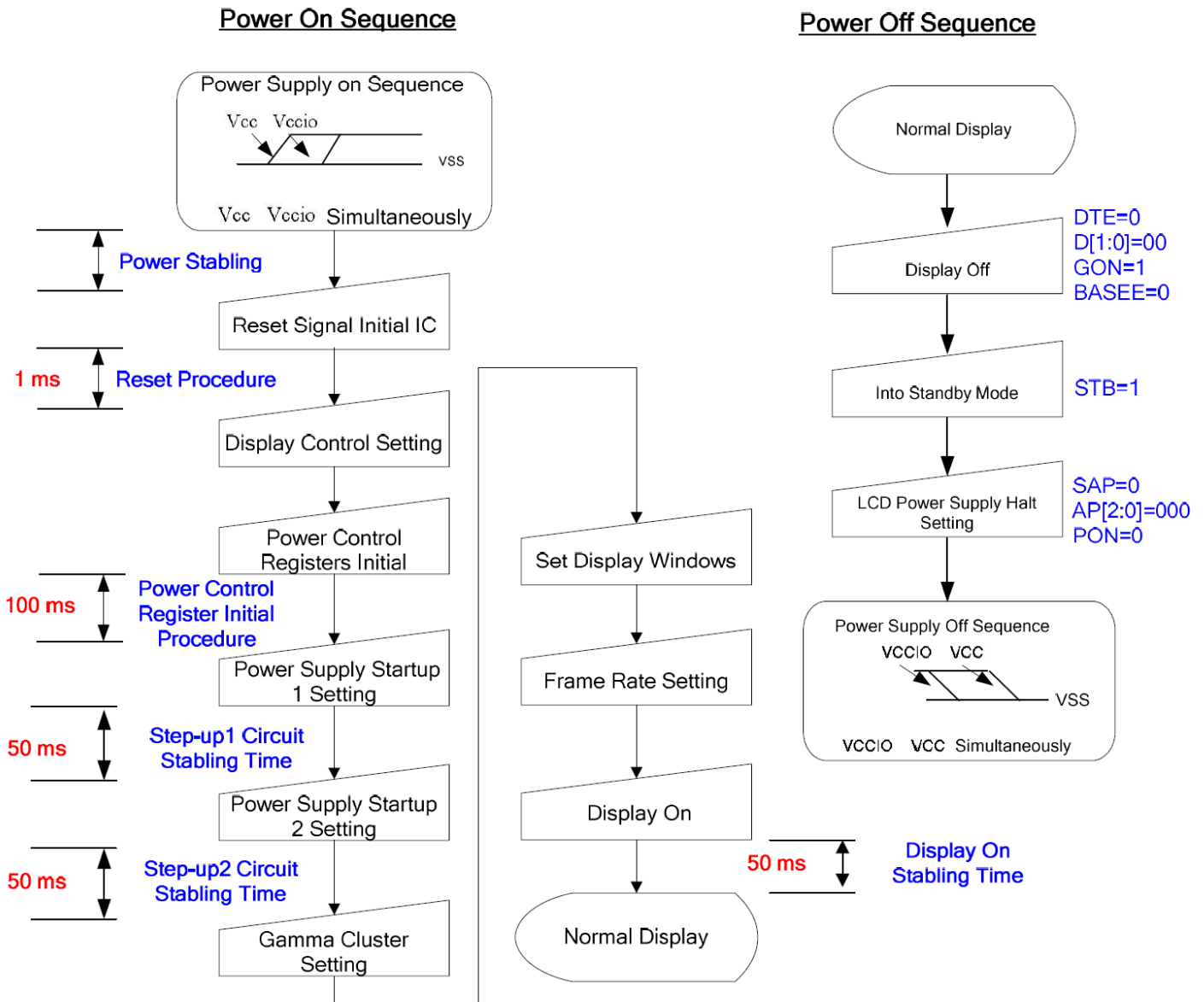

Figure 3 Write-to-Read and Read-to-Write Timing



### 3.6 POWER SEQUENCE

For more information, please refer to ST7775R datasheet.



## 4 OPTICAL SPECIFICATION

### 4.1 OPTICAL CHARACTERISTICS

Measuring instruments: FPM520 of Westar technologies, utilized SR-3 for Chromaticity  
 Driving condition: VCC=VCCIO = 2.8V, GND = 0V  
 Backlight: IF=60mA  
 Measured temperature: Ta = 25° C

Item		Symbol	Condition	MIN	TYP	MAX	Unit	Note
Response Time		TR+TF	$\theta=\phi=0^\circ$ Normal Viewing Angle	-	8	16	ms	2
Contrast Ratio		CR		500	700	-		3
Viewing Angle	Left	$\theta_L$	CR $\geq$ 10	-	80	-	deg	4
	Right	$\theta_R$		-	80	-	deg	
	Up	$\phi_U$		-	80	-	deg	
	Down	$\phi_D$		-	80	-	deg	
Colour Chromaticity	Red	Rx	CR $\geq$ 10	0.606	0.626	0.646	-	5
		Ry		0.314	0.334	0.354	-	
	Green	Gx		0.257	0.277	0.394	-	
		Gy		0.529	0.549	0.569	-	
	Blue	Bx		0.122	0.142	0.164	-	
		By		0.102	0.122	0.142	-	
	White	Wx		0.283	0.303	0.323	-	
		Wy		0.305	0.325	0.345	-	
Centre Brightness				-	350	-	cd/m <sup>2</sup>	6
Brightness Distribution				80	-	-	%	7

### 4.1.1 Test Method

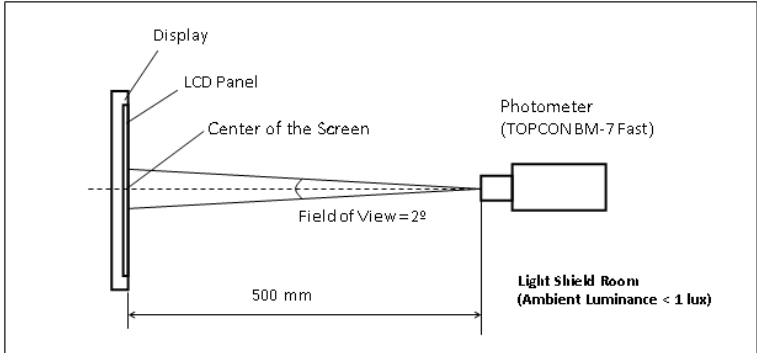
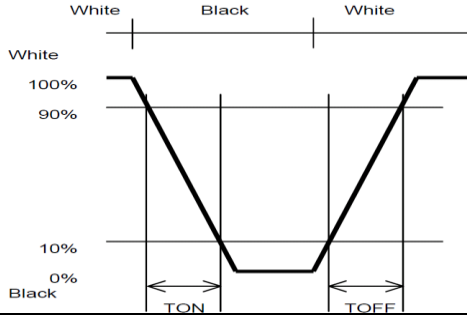
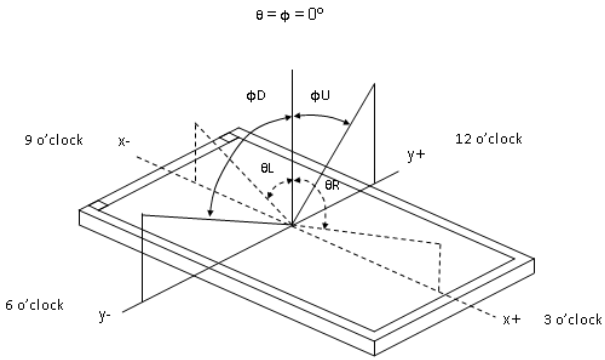
Note	Item	Test method
1	Setup	<p>The display should be stabilised at a given temperature for 30 minutes to avoid abrupt temperature change during measuring. In order to stabilise the luminance, measurements should be executed after lighting the backlight for 30 minutes in a windless room.</p> 
2	Response time	<p>Measure output signal waveform by the luminance meter when raster of window pattern is changed from white to black and from black to white.</p> 
3	Contrast ratio	<p>Measure maximum brightness and minimum brightness at the centre of the screen by displaying raster or window pattern. Then calculate the ratio between these two values.</p> $\text{Contrast Ratio (CR)} = \frac{\text{Brightness of unselected position (white)}}{\text{Brightness of selected position (black)}}$
4	Viewing angle Horizontal $\theta$ Vertical $\phi$	<p>Move the luminance meter from right to left and up and down and determinate the angles where contrast ratio is 10</p> 
5	Colour chromaticity	Measure chromaticity coordinates x and y of CIE1931 colorimetric system
6	Centre brightness	Measure the brightness at the centre of the screen
7	Brightness distribution	<p>(Brightness distribution) = <math>100 \times B/A \%</math>  A: max. brightness of the 9 points  B: min. brightness of the 9 points</p>

## 5 BACKLIGHT SPECIFICATION

### 5.1 LED DRIVING CONDITIONS

Item	Symbol	Condition	Min	Typ	Max	Unit
Forward Current	IF	Ta=25 °C, VF=3.2V	-	60	-	mA
Forward Voltage	VF	Ta= 25°C, IF= 20mA/LED	-	3.2	-	V
Estimated Life of LED	LL	Ta= 25°C, IF= 60mA Note	(50000)	-	-	hr

**Note:**

- The lifetime of the LED is defined as a period till the brightness of the LED decreases to the half of its initial value.
- This figure is given as a reference purpose only, and not a guarantee.
- This figure is estimated for an LED operating alone.  
The performance of an LED may differ when assembled as a monitor together with a TFT panel due to different environmental temperature.
- Estimated lifetime could vary on a different temperature and usually higher temperature could reduce the life significantly.

### 5.2 LED CIRCUIT

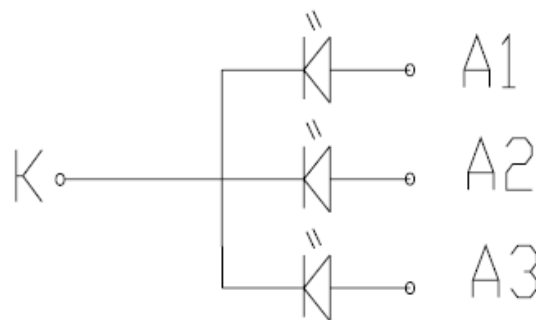

LED CIRCUIT DIAGRAM

## 6 QUALITY ASSURANCE SPECIFICATION

### 6.1 DELIVERY INSPECTION STANDARDS

#### 6.1.1 Inspection Conditions

Inspection distance: 30 cm ± 2 cm  
Viewing angle: ±45°

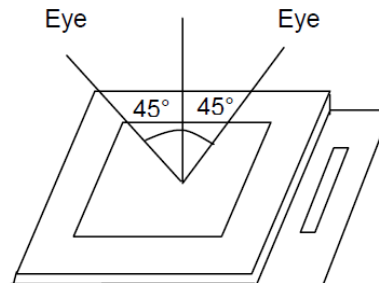

#### 6.1.2 Environmental Conditions

Ambient temperature: 25°C ±5°C  
Ambient humidity: 65%±10% RH  
Ambient illumination: Single fluorescent lamp (300~700 Lux )

#### 6.1.3 Sampling Conditions

1. Lot size: quantity of shipment lot per model
2. Sampling method:

Sampling Plan		ANSI / ASQC Z1.4-1993
		Normal inspection, Single Sampling
AQL	Major Defect	0.65%
	Minor Defect	1.5%

#### 6.1.4 Definition of Area

A zone: active area

B zone: viewing area

C zone: Outside ( Zone A+B) which can not be seen after assembly by customer

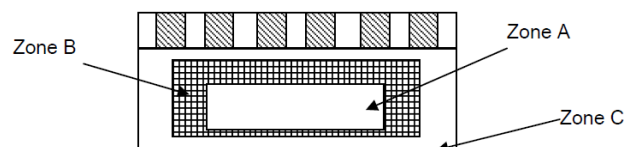

Note: As a general rule, visual defects in Zone C can be ignored when they do not affect product function or appearance after assembly by customer.



### 6.1.5 Basic Principle

A set of sample to indicate the limit of acceptable quality level shall be discussed should a dispute occur.

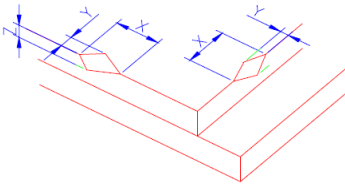
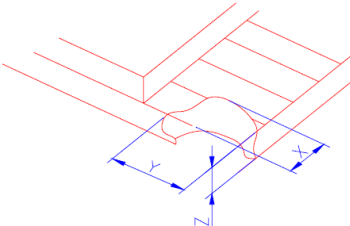
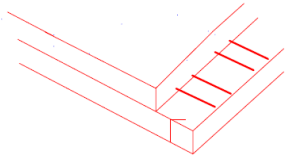

### 6.1.6 Inspection Criteria

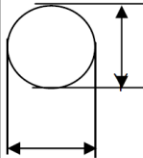
Number	Items	Criteria(mm)						
1.0 LCD Crack/Broken	(1) The edge of LCD broken	 <table border="1" data-bbox="858 772 1342 918"> <thead> <tr> <th>X</th> <th>Y</th> <th>Z</th> </tr> </thead> <tbody> <tr> <td>≤3.0mm</td> <td>&lt;Inner border line of the seal</td> <td>≤T</td> </tr> </tbody> </table>	X	Y	Z	≤3.0mm	<Inner border line of the seal	≤T
X	Y	Z						
≤3.0mm	<Inner border line of the seal	≤T						
Z: Height L: Length of ITO, T: Height of LCD	(2)LCD corner broken	 <table border="1" data-bbox="906 1243 1279 1332"> <thead> <tr> <th>X</th> <th>Y</th> <th>Z</th> </tr> </thead> <tbody> <tr> <td>≤3.0mm</td> <td>≤L</td> <td>≤T</td> </tr> </tbody> </table>	X	Y	Z	≤3.0mm	≤L	≤T
	X	Y	Z					
≤3.0mm	≤L	≤T						
(3) LCD crack	 <p>Crack Not allowed</p>							

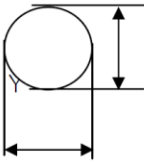
Number	Items	Criteria (mm)																									
2.0	Spot defect  $\Phi = (X+Y)/2$	① light dot (LCD/TP/Polarizer black/white spot , light dot, pinhole, dent, stain) <table border="1" data-bbox="486 358 1228 638"> <thead> <tr> <th rowspan="2">Zone Size (mm)</th> <th colspan="3">Acceptable Qty</th> </tr> <tr> <th>A</th> <th>B</th> <th>C</th> </tr> </thead> <tbody> <tr> <td><math>\Phi \leq 0.10</math></td> <td colspan="3">Ignore</td> </tr> <tr> <td><math>0.10 &lt; \Phi \leq 0.15</math></td> <td colspan="3">3( distance <math>\geq 10\text{mm}</math>)</td> </tr> <tr> <td><math>0.15 &lt; \Phi \leq 0.2</math></td> <td colspan="3">1</td> </tr> <tr> <td><math>0.2 &lt; \Phi</math></td> <td colspan="3">0</td> </tr> </tbody> </table>	Zone Size (mm)	Acceptable Qty			A	B	C	$\Phi \leq 0.10$	Ignore			$0.10 < \Phi \leq 0.15$	3( distance $\geq 10\text{mm}$ )			$0.15 < \Phi \leq 0.2$	1			$0.2 < \Phi$	0				
		Zone Size (mm)		Acceptable Qty																							
			A	B	C																						
		$\Phi \leq 0.10$	Ignore																								
		$0.10 < \Phi \leq 0.15$	3( distance $\geq 10\text{mm}$ )																								
		$0.15 < \Phi \leq 0.2$	1																								
		$0.2 < \Phi$	0																								
		② Dim spot (LCD/TP/Polarizer dim dot, light leakage, dark spot) <table border="1" data-bbox="486 705 1252 996"> <thead> <tr> <th rowspan="2">Zone Size (mm)</th> <th colspan="3">Acceptable Qty</th> </tr> <tr> <th>A</th> <th>B</th> <th>C</th> </tr> </thead> <tbody> <tr> <td><math>\Phi \leq 0.1</math></td> <td colspan="3">Ignore</td> </tr> <tr> <td><math>0.1 &lt; \Phi \leq 0.2</math></td> <td colspan="3">2( distance <math>\geq 10\text{mm}</math>)</td> </tr> <tr> <td><math>0.2 &lt; \Phi \leq 0.3</math></td> <td colspan="3">1</td> </tr> <tr> <td><math>\Phi &gt; 0.3</math></td> <td colspan="3">0</td> </tr> </tbody> </table>	Zone Size (mm)	Acceptable Qty			A	B	C	$\Phi \leq 0.1$	Ignore			$0.1 < \Phi \leq 0.2$	2( distance $\geq 10\text{mm}$ )			$0.2 < \Phi \leq 0.3$	1			$\Phi > 0.3$	0				
		Zone Size (mm)		Acceptable Qty																							
			A	B	C																						
$\Phi \leq 0.1$	Ignore																										
$0.1 < \Phi \leq 0.2$	2( distance $\geq 10\text{mm}$ )																										
$0.2 < \Phi \leq 0.3$	1																										
$\Phi > 0.3$	0																										
③ Polarizer accidented spot <table border="1" data-bbox="486 1075 1252 1299"> <thead> <tr> <th rowspan="2">Zone Size (mm)</th> <th colspan="3">Acceptable Qty</th> </tr> <tr> <th>A</th> <th>B</th> <th>C</th> </tr> </thead> <tbody> <tr> <td><math>\Phi \leq 0.2</math></td> <td colspan="3">Ignore</td> </tr> <tr> <td><math>0.2 &lt; \Phi \leq 0.5</math></td> <td colspan="3">2( distance <math>\geq 10\text{mm}</math>)</td> </tr> <tr> <td><math>\Phi &gt; 0.5</math></td> <td colspan="3">0</td> </tr> </tbody> </table>	Zone Size (mm)	Acceptable Qty			A	B	C	$\Phi \leq 0.2$	Ignore			$0.2 < \Phi \leq 0.5$	2( distance $\geq 10\text{mm}$ )			$\Phi > 0.5$	0										
Zone Size (mm)		Acceptable Qty																									
	A	B	C																								
$\Phi \leq 0.2$	Ignore																										
$0.2 < \Phi \leq 0.5$	2( distance $\geq 10\text{mm}$ )																										
$\Phi > 0.5$	0																										
Line defect (LCD/TP /Polarizer black/white line, scratch, stain) <table border="1" data-bbox="486 1344 1244 1624"> <thead> <tr> <th rowspan="2">Width(mm)</th> <th rowspan="2">Length(mm)</th> <th colspan="3">Acceptable Qty</th> </tr> <tr> <th>A</th> <th>B</th> <th>C</th> </tr> </thead> <tbody> <tr> <td><math>\Phi \leq 0.03</math></td> <td>Ignore</td> <td colspan="3">Ignore</td> </tr> <tr> <td><math>0.03 &lt; W \leq 0.05</math></td> <td><math>L \leq 3.0</math></td> <td colspan="2"><math>N \leq 2</math></td> <td rowspan="2">Ignore</td> </tr> <tr> <td><math>0.05 &lt; W \leq 0.08</math></td> <td><math>L \leq 2.0</math></td> <td colspan="2"><math>N \leq 2</math></td> </tr> <tr> <td><math>0.08 &lt; W</math></td> <td colspan="4">Define as spot defect</td> </tr> </tbody> </table>	Width(mm)	Length(mm)	Acceptable Qty			A	B	C	$\Phi \leq 0.03$	Ignore	Ignore			$0.03 < W \leq 0.05$	$L \leq 3.0$	$N \leq 2$		Ignore	$0.05 < W \leq 0.08$	$L \leq 2.0$	$N \leq 2$		$0.08 < W$	Define as spot defect			
Width(mm)			Length(mm)	Acceptable Qty																							
	A	B		C																							
$\Phi \leq 0.03$	Ignore	Ignore																									
$0.03 < W \leq 0.05$	$L \leq 3.0$	$N \leq 2$		Ignore																							
$0.05 < W \leq 0.08$	$L \leq 2.0$	$N \leq 2$																									
$0.08 < W$	Define as spot defect																										

Items	Criteria (mm)																																																																	
Spot defect  $\Phi = (X+Y)/2$	<p>① light dot (LCD/TP/Polarizer black/white spot , light dot, pinhole, dent, stain)</p> <table border="1" data-bbox="491 667 1225 947"> <thead> <tr> <th rowspan="2">Zone Size (mm)</th> <th colspan="3">Acceptable Qty</th> </tr> <tr> <th>A</th> <th>B</th> <th>C</th> </tr> </thead> <tbody> <tr> <td><math>\Phi \leq 0.10</math></td> <td colspan="3">Ignore</td> </tr> <tr> <td><math>0.10 &lt; \Phi \leq 0.15</math></td> <td colspan="3">3( distance <math>\geq 10\text{mm}</math>)</td> </tr> <tr> <td><math>0.15 &lt; \Phi \leq 0.2</math></td> <td colspan="3">1</td> </tr> <tr> <td><math>0.2 &lt; \Phi</math></td> <td colspan="3">0</td> </tr> </tbody> </table> <p>② Dim spot (LCD/TP/Polarizer dim dot, light leakage, dark spot)</p> <table border="1" data-bbox="491 1016 1246 1301"> <thead> <tr> <th rowspan="2">Zone Size (mm)</th> <th colspan="3">Acceptable Qty</th> </tr> <tr> <th>A</th> <th>B</th> <th>C</th> </tr> </thead> <tbody> <tr> <td><math>\Phi \leq 0.1</math></td> <td colspan="3">Ignore</td> </tr> <tr> <td><math>0.1 &lt; \Phi \leq 0.2</math></td> <td colspan="3">2( distance <math>\geq 10\text{mm}</math>)</td> </tr> <tr> <td><math>0.2 &lt; \Phi \leq 0.3</math></td> <td colspan="3">1</td> </tr> <tr> <td><math>\Phi &gt; 0.3</math></td> <td colspan="3">0</td> </tr> </tbody> </table> <p>③ Polarizer accidented spot</p> <table border="1" data-bbox="491 1375 1134 1617"> <thead> <tr> <th rowspan="2">Zone Size (mm)</th> <th colspan="3">Acceptable Qty</th> </tr> <tr> <th>A</th> <th>B</th> <th>C</th> </tr> </thead> <tbody> <tr> <td><math>\Phi \leq 0.2</math></td> <td colspan="3">Ignore</td> </tr> <tr> <td><math>0.2 &lt; \Phi \leq 0.5</math></td> <td colspan="3">2( distance <math>\geq 10\text{mm}</math>)</td> </tr> <tr> <td><math>\Phi &gt; 0.5</math></td> <td colspan="3">0</td> </tr> </tbody> </table>	Zone Size (mm)	Acceptable Qty			A	B	C	$\Phi \leq 0.10$	Ignore			$0.10 < \Phi \leq 0.15$	3( distance $\geq 10\text{mm}$ )			$0.15 < \Phi \leq 0.2$	1			$0.2 < \Phi$	0			Zone Size (mm)	Acceptable Qty			A	B	C	$\Phi \leq 0.1$	Ignore			$0.1 < \Phi \leq 0.2$	2( distance $\geq 10\text{mm}$ )			$0.2 < \Phi \leq 0.3$	1			$\Phi > 0.3$	0			Zone Size (mm)	Acceptable Qty			A	B	C	$\Phi \leq 0.2$	Ignore			$0.2 < \Phi \leq 0.5$	2( distance $\geq 10\text{mm}$ )			$\Phi > 0.5$	0		
Zone Size (mm)	Acceptable Qty																																																																	
	A	B	C																																																															
$\Phi \leq 0.10$	Ignore																																																																	
$0.10 < \Phi \leq 0.15$	3( distance $\geq 10\text{mm}$ )																																																																	
$0.15 < \Phi \leq 0.2$	1																																																																	
$0.2 < \Phi$	0																																																																	
Zone Size (mm)	Acceptable Qty																																																																	
	A	B	C																																																															
$\Phi \leq 0.1$	Ignore																																																																	
$0.1 < \Phi \leq 0.2$	2( distance $\geq 10\text{mm}$ )																																																																	
$0.2 < \Phi \leq 0.3$	1																																																																	
$\Phi > 0.3$	0																																																																	
Zone Size (mm)	Acceptable Qty																																																																	
	A	B	C																																																															
$\Phi \leq 0.2$	Ignore																																																																	
$0.2 < \Phi \leq 0.5$	2( distance $\geq 10\text{mm}$ )																																																																	
$\Phi > 0.5$	0																																																																	

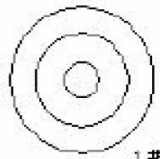
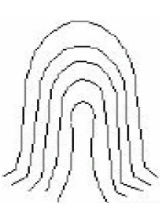
Line defect (LCD/TP /Polarizer black/white line, scratch, stain)	Width(mm)	Length(mm)	Acceptable Qty		
			A	B	C
	$\Phi \leq 0.03$	Ignore	Ignore		Ignore
	$0.03 < W \leq 0.05$	$L \leq 3.0$	$N \leq 2$		
$0.05 < W \leq 0.08$	$L \leq 2.0$	$N \leq 2$			
$0.08 < W$	Define as spot defect				
Polarizer Bubble	Zone	Acceptable Qty			
	Size (mm)	A	B	C	
	$\Phi \leq 0.2$	Ignore		Ignore	
	$0.2 < \Phi \leq 0.4$	2(distance $\geq 10\text{mm}$ )			
	$0.4 < \Phi \leq 0.6$	1			
$0.6 < \Phi$	0				
SMT	According to IPC-A-610C class II standard . Function defect and missing part are major defect ,the others are minor defect.				
TP bubble/ accidented spot	Size $\Phi$ (mm)	Acceptable Qty			
		A	B	C	
	$\Phi \leq 0.1$	Ignore		Ignore	
	$0.1 < \Phi \leq 0.2$	2			
	$0.2 < \Phi \leq 0.3$	1			
$0.3 < \Phi$	0				
Assembly deflection	beyond the edge of backlight $\leq 0.15\text{mm}$				

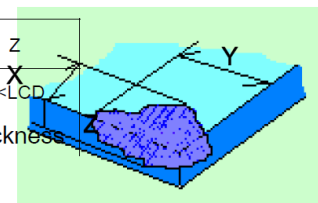
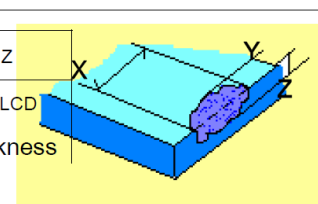
5.0	TP Related	Newton Ring	Newton area > 1/3 NG	Ring TP area	 1 规律性						
		Newton Ring	Newton area ≤ 1/3 OK	Ring TP area	 2 非规律性						
					 似牛顿环						
	TP corner broken X : length Y : width Z : height	<table border="1"> <tr> <td>X</td> <td>Y</td> </tr> <tr> <td>X ≤ 3.0mm</td> <td>Y ≤ 3.0mm</td> </tr> </table>	X	Y	X ≤ 3.0mm	Y ≤ 3.0mm	<table border="1"> <tr> <td>Z</td> </tr> <tr> <td>Z &lt; LCD thickness</td> </tr> </table>	Z	Z < LCD thickness		<p>* Circuitry broken is not allowed.</p>
X	Y										
X ≤ 3.0mm	Y ≤ 3.0mm										
Z											
Z < LCD thickness											
	TP edge broken X : length Y : width Z : height	<table border="1"> <tr> <td>X</td> <td>Y</td> </tr> <tr> <td>X ≤ 6.0mm</td> <td>Y ≤ 2.0mm</td> </tr> </table>	X	Y	X ≤ 6.0mm	Y ≤ 2.0mm	<table border="1"> <tr> <td>Z</td> </tr> <tr> <td>Z &lt; LCD thickness</td> </tr> </table>	Z	Z < LCD thickness		<p>* Circuitry broken is not allowed.</p>
X	Y										
X ≤ 6.0mm	Y ≤ 2.0mm										
Z											
Z < LCD thickness											

Criteria ( functional items)

Number	Items	Criteria (mm)
1	No display	Not allowed
2	Missing segment	Not allowed
3	Short	Not allowed
4	Backlight no lighting	Not allowed
5	TP no function	Not allowed

### 6.1.7 Classification of Defects

Visual defects (except no or wrong label) are treated as minor defects, while electrical defects are treated as major defects.

Two minor defects are equal to one major defect in lot sampling inspection.

### 6.1.8 Identification / marking criteria

Any unit with illegible / wrong / double or no marking / label shall be rejected.

## 6.2 DEALING WITH CUSTOMER COMPLAINTS

---

### 6.2.1 Non-conforming analysis

Purchaser should supply Densitron with detailed data of non-conforming sample. After accepting it, Densitron should complete the analysis in two weeks from receiving the sample.

If the analysis cannot be completed on time, Densitron must inform the purchaser.

### 6.2.2 Handling of non-conforming displays

If any non-conforming displays are found during customer acceptance inspection which Densitron is clearly responsible for, return them to Densitron.

Both Densitron and customer should analyse the reason and discuss the handling of non-conforming displays when the reason is not clear.

Equally, both sides should discuss and come to agreement for issues pertaining to modification of Densitron quality assurance standard.

## 7 RELIABILITY SPECIFICATION

### 7.1 RELIABILITY TESTS

Test Item		Test Condition
Durability Test	High Temperature Storage	Ta= 80°C      96h
	Low Temperature Storage	Ta=-30°C      96h
	Temperature Cycle Storage	-20°C ↔ 70°C for 30 min, 20 cycles
	High Temperature Operation	Tp= 70°C      96h
	Low Temperature Operation	Tp= -20°C      96h
	High Temperature & Humidity Operation	Tp= 40°C    RH= 90%    96h Non condensing
	Box Drop Test	1 corner, 3 edges, 6 faces, 66 cm height
	ESD test	150pF,330ohm, ±6kV (contact) / ±8kV (Air), 5 points/panel, 10 times/point

Note: Ta=ambient temperature Tp= Panel temperature

Notes:

1. No dew condensation to be observed.
2. The function test shall be conducted after 4 hours storage at the normal temperature and humidity after removed from the test chamber.
3. No cosmetic or functional defects should be allowed.
4. Total current consumption should be less than twice the initial value.

## 8 HANDLING PRECAUTIONS

### **Safety**

If the LCD panel breaks, be careful not to get the liquid crystal fluid in your mouth or in your eyes. If the liquid crystal touches your skin or clothes, wash it off immediately using soap and plenty of water.

### **Mounting and Design**

Place a transparent plate (e.g. acrylic, polycarbonate or glass) on the display surface to protect the display from external pressure. Leave a small gap between the transparent plate and the display surface.

When assembling with a zebra connector, clean the surface of the pads with alcohol and keep the surrounding air very clean.

Design the system so that no input signal is given unless the power supply voltage is applied.

### **Caution during LCD cleaning**

Lightly wipe the display surface with a soft cloth soaked with Isopropyl alcohol, Ethyl alcohol or Trichlorotrifluoroethane.

Do not wipe the display surface with dry or hard materials that will damage the polariser surface. Do not use aromatic solvents (toluene and xylene), or ketonic solvents (ketone and acetone).

### **Caution against static charge**

As the display uses C-MOS LSI drivers, connect any unused input terminal to VDD or VSS. Do not input any signals before power is turned on. Also, ground your body, work/assembly table and assembly equipment to protect against static electricity.

### **Packaging**

Displays use LCD elements, and must be treated as such. Avoid strong shock and drop from a height. To prevent displays from degradation, do not operate or store them exposed directly to sunshine or high temperature/humidity.

### **Caution during operation**

It is indispensable to drive the display within the specified voltage limit since excessive voltage shortens its life. Direct current causes an electrochemical reaction with remarkable deterioration of the display quality. Give careful consideration to prevent direct current during ON/OFF timing and during operation. Response time is extremely delayed at temperatures lower than the operating temperature range while, at high temperatures, displays become dark. However, this phenomenon is reversible and does not mean a malfunction or a display that has been permanently damaged. If the display area is pushed on hard during operation, some graphics will be abnormally displayed but returns to a normal condition after turning off the display once. Even a small amount of condensation on the contact pads (terminals) can cause an electro-chemical reaction which causes missing rows and columns. Give careful attention to avoid condensation.

### **Storage**

Store the display in a dark place where the temperature is 25°C ± 10°C and the humidity below 50%RH. Store the display in a clean environment, free from dust, organic solvents and corrosive gases.

Do not crash, shake or jolt the display (including accessories).

Product No.	DET020CFNCNT0-1A	REV. 1.0
-------------	------------------	----------

Page	24 / 24
------	---------