

## GLASS PASSIVATED BRIDGE RECTIFIERS

**DF005S--DF10S**

### FEATURES

- Rating to 1000V PRVP
- Ideal for printed circuit board
- Low forward voltage drop, high current capability.
- Reliable low cost construction utilizing molded plastic technique results in inexpensive product
- The plastic material has UL flammability classification 94V-0

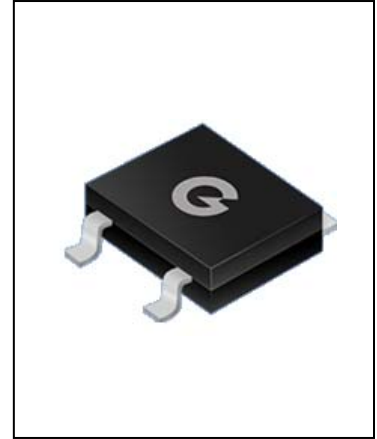

### MECHANICAL DATA

- Mounting position : Any

### Maximum Ratings (@TA = 25°C unless otherwise specified)

Characteristic	Symbol	DF005S	DF01S	DF02S	DF04S	DF06S	DF08S	DF10S	UNITS
Maximum Recurrent Peak Reverse Voltage	$V_{RRM}$	50	100	200	400	600	800	1000	V
Maximum RMS Reverse Voltage	$V_{RMS}$	35	75	140	280	420	560	700	V
Maximum DC Blocking Voltage	$V_{DC}$	50	100	200	400	600	800	1000	V
Maximum average forward Output current @TA=40°C	$I_{F(AV)}$	1.0							A
Peak forward surge current 8.3ms single half-sine-wave superimposed on rated load(JEDEC METHOD)	$I_{FSM}$	50							A

### Thermal Characteristics

Characteristic	Symbol	DF005S	DF01S	DF02S	DF04S	DF06S	DF08S	DF10S	UNITS
I t Rating for fusing (t < 8.3ms)	$I^2 t$	10.4							A <sup>2</sup> S
Typical Junction Capacitance per element	$C_J$	25							pF
Typical Thermal Resistance (Note 2)	$R_{\theta JA}$	40							°C/W
Operating junction temperature range	$T_J$	-55 -- +150							°C
Storage temperature range	$T_{STG}$	-55 -- +150							°C

### Electrical Characteristics (@TA = 25°C unless otherwise specified)

Characteristic	Symbol	DF005S	DF01S	DF02S	DF04S	DF06S	DF08S	DF10S	UNITS
Maximum instantaneous forward voltage at 1.0 ADC	$V_F$	1.1							V
Maximum reverse current @T <sub>J</sub> =25°C at rated DC blocking voltage @T <sub>J</sub> =125°C	$I_R$	5.0							μA
		500							

NOTES : 1. Measured at 1.0MHz and applied reverse voltage of 4.0V DC.

2. Thermal resistance from junction to ambient mounted on P.C.B with 0.5x0.5"(13x13mm) copper pads.



**GLASS PASSIVATED BRIDGE RECTIFIERS**

**DF005S--DF10S**

**PACKAGE OUTLINE DIMENSIONS**

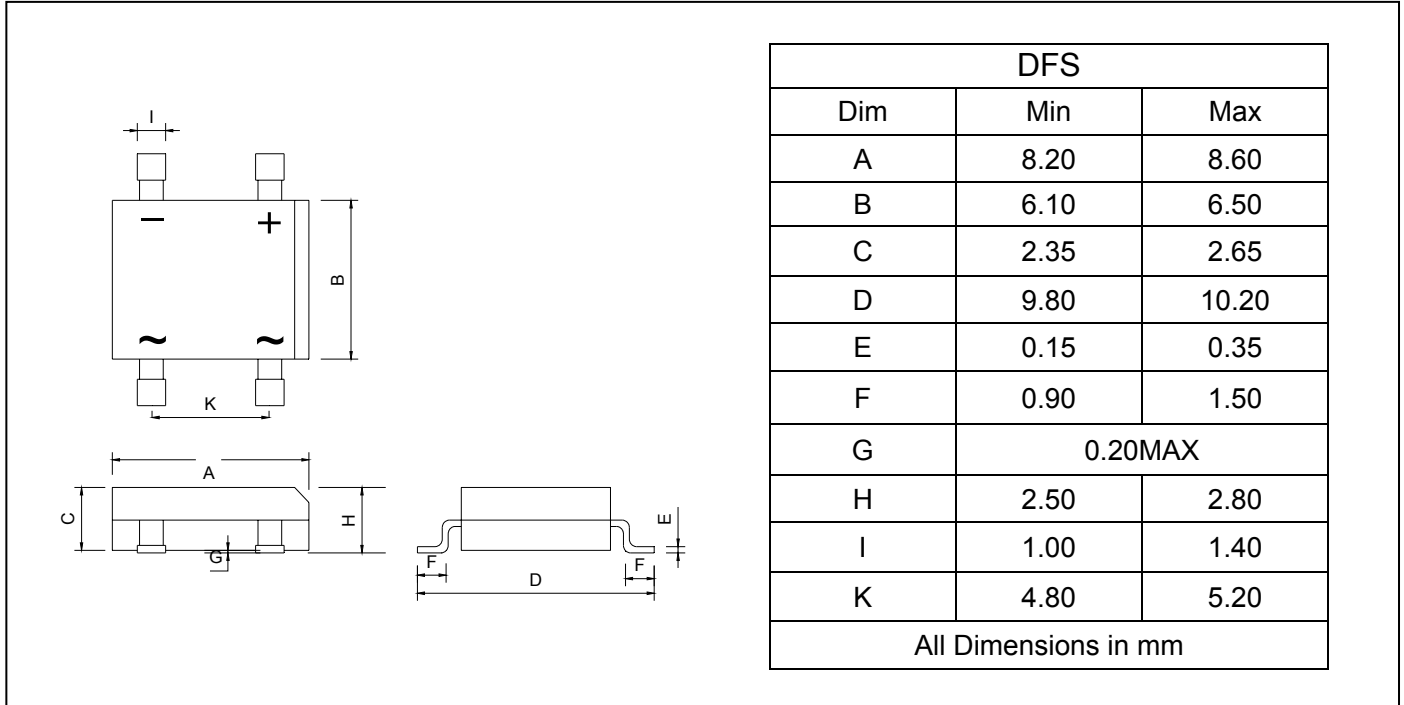

**PACKAGE INFORMATION**

Device	Package	Shipping
DF005S--DF10S	DFS	50unit/pipe



# GLASS PASSIVATED BRIDGE RECTIFIERS

# DF005S--DF10S

