

Features

- Glass Passivated Die Construction
- Low Forward Voltage Drop
- High Current Capability
- High Surge Current Capability
- Designed for Surface Mount Application
- Plastic Material – UL Recognition Flammability Classification 94V-0

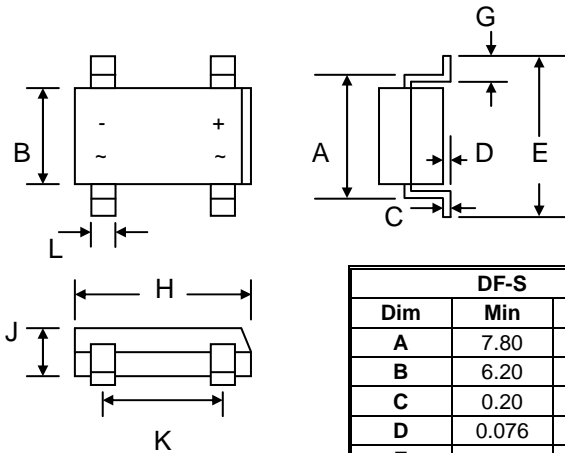

DF-S		
Dim	Min	Max
A	7.80	8.50
B	6.20	6.50
C	0.20	0.35
D	0.076	0.33
E	—	10.40
G	1.02	1.53
H	8.13	8.80
J	2.20	2.50
K	5.00	5.20
L	1.00	1.20
All Dimensions in mm		

Mechanical Data

- Case: DF-S, Molded Plastic
- Terminals: Plated Leads Solderable per MIL-STD-202, Method 208
- Polarity: As Marked on Case
- Weight: 0.38 grams (approx.)
- Mounting Position: Any
- Marking: Type Number
- **Lead Free: For RoHS / Lead Free Version, Add “-LF” Suffix to Part Number, See Page 4**

Maximum Ratings and Electrical Characteristics @ $T_A=25^\circ\text{C}$ unless otherwise specified

Single Phase, half wave, 60Hz, resistive or inductive load.
For capacitive load, derate current by 20%.

Characteristic	Symbol	DF 150S	DF 151S	DF 152S	DF 154S	DF 156S	DF 158S	DF 1510S	Unit
Peak Repetitive Reverse Voltage	V_{RRM}								
Working Peak Reverse Voltage	V_{RWM}	50	100	200	400	600	800	1000	V
DC Blocking Voltage	V_R								
RMS Reverse Voltage	$V_{R(RMS)}$	35	70	140	280	420	560	700	V
Average Rectified Output Current @ $T_A = 40^\circ\text{C}$	I_o	1.5							A
Non-Repetitive Peak Forward Surge Current 8.3ms Single Half Sine-Wave Superimposed on Rated Load (JEDEC Method)	I_{FSM}	50							A
Forward Voltage per element @ $I_F = 1.5\text{A}$	V_{FM}	1.1							V
Peak Reverse Current @ $T_A = 25^\circ\text{C}$ At Rated DC Blocking Voltage @ $T_A = 125^\circ\text{C}$	I_{RM}	5.0 500							μA
I^2t Rating for Fusing ($t < 8.3\text{ms}$)	I^2t	10							A^2s
Typical Junction Capacitance per leg (Note 1)	C_J	25							pF
Typical Thermal Resistance per leg (Note 2)	R_{JA} R_{JL}	40 15							$^\circ\text{C}/\text{W}$
Operating and Storage Temperature Range	T_J, T_{STG}	-65 to +150							$^\circ\text{C}$

Note: 1. Measured at 1.0 MHz and applied reverse voltage of 4.0V D.C.
2. Mounted on PC board with 13 x 13mm copper pad.

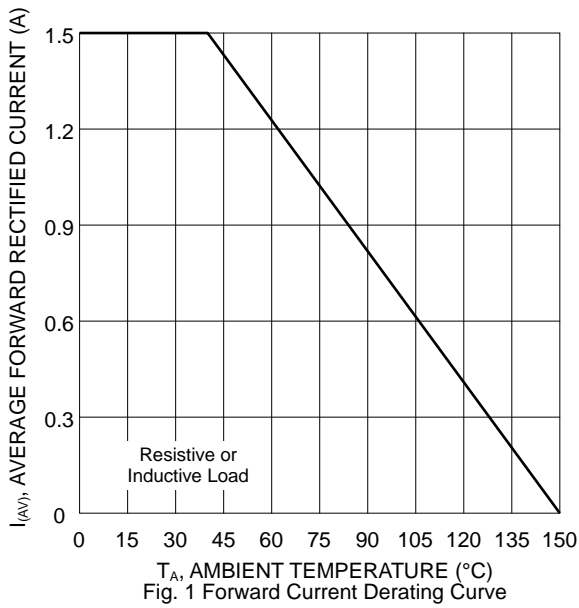

Fig. 1 Forward Current Derating Curve

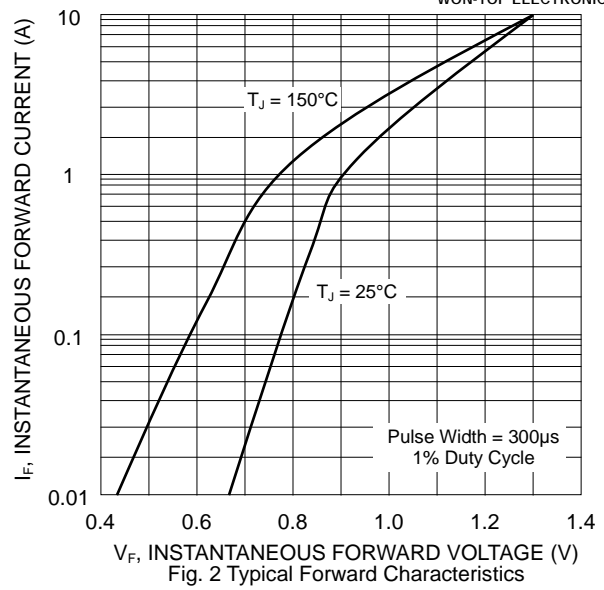

Fig. 2 Typical Forward Characteristics

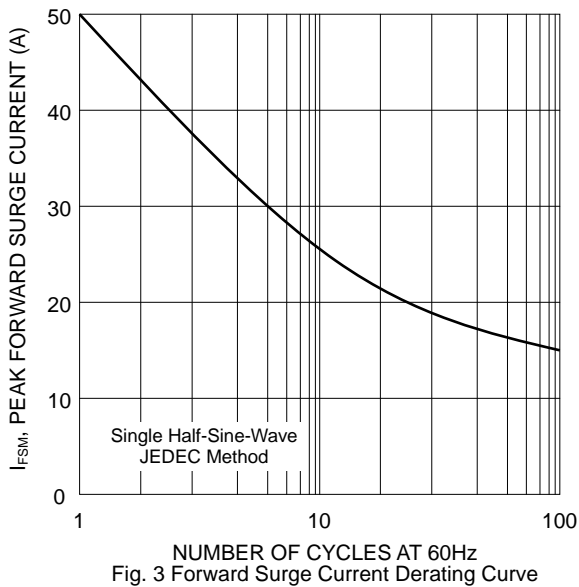

Fig. 3 Forward Surge Current Derating Curve

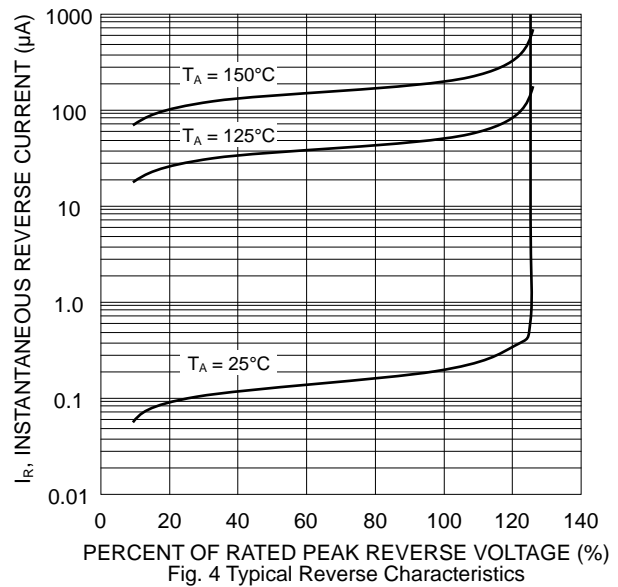

Fig. 4 Typical Reverse Characteristics

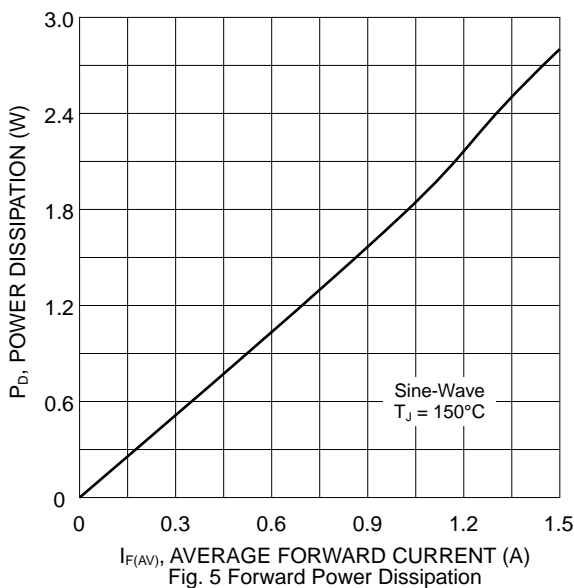

Fig. 5 Forward Power Dissipation

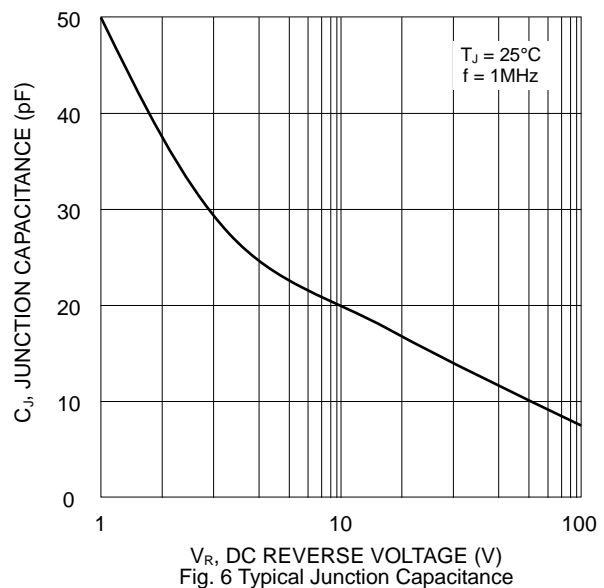
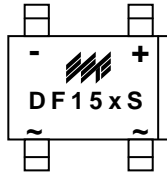

Fig. 6 Typical Junction Capacitance

MARKING INFORMATION



DF15xS = Device Number
 x = 0, 1, 2, 4, 6, 8 or 10
 Polarity = As Marked on Body

RECOMMENDED FOOTPRINT

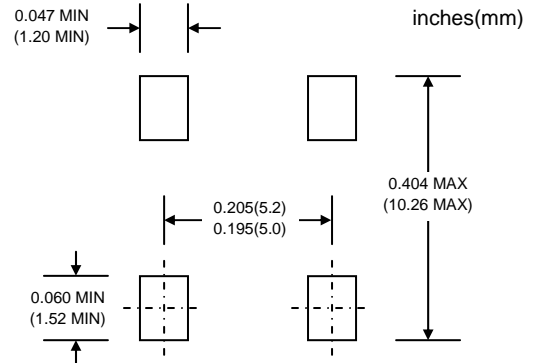

PACKAGING INFORMATION

TAPE & REEL

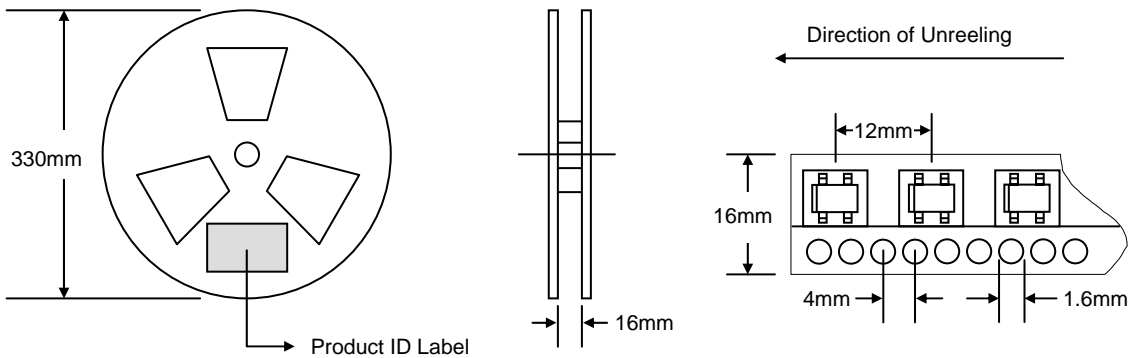

Reel Diameter (mm)	Quantity (PCS)	Inner Box Size L x W x H (mm)	Quantity (PCS)	Carton Size L x W x H (mm)	Quantity (PCS)	Approx. Gross Weight (KG)
330	1,500	340 x 337 x 45	3,000	370 x 370 x 420	24,000	17.0

Note: 1. Anti-static or paper reel, blue or white color.
 2. Components are packed in accordance with EIA standard 481-1 and 481-2.

ORDERING INFORMATION

Product No.	Package Type	Shipping Quantity
DF150S-T3	DIL Bridge SMD	1500/Tape & Reel
DF151S-T3	DIL Bridge SMD	1500/Tape & Reel
DF152S-T3	DIL Bridge SMD	1500/Tape & Reel
DF154S-T3	DIL Bridge SMD	1500/Tape & Reel
DF156S-T3	DIL Bridge SMD	1500/Tape & Reel
DF158S-T3	DIL Bridge SMD	1500/Tape & Reel
DF1510S-T3	DIL Bridge SMD	1500/Tape & Reel

1. Shipping quantity given is for minimum packing quantity only. For minimum order quantity, please consult the Sales Department.
2. **To order RoHS / Lead Free version (with Lead Free finish), add "-LF" suffix to part number above. For example, DF150S-T3-LF.**

WON-TOP ELECTRONICS and  are registered trademarks of Won-Top Electronics Co., Ltd (WTE). WTE has checked all information carefully and believes it to be correct and accurate. However, WTE cannot assume any responsibility for inaccuracies. Furthermore, this information does not give the purchaser of semiconductor devices any license under patent rights to manufacturer. WTE reserves the right to change any or all information herein without further notice.

WARNING: DO NOT USE IN LIFE SUPPORT EQUIPMENT. WTE power semiconductor products are not authorized for use as critical components in life support devices or systems without the express written approval.

Won-Top Electronics Co., Ltd.
No. 44 Yu Kang North 3rd Road,
Chine Chen Dist., Kaohsiung 806, Taiwan
Phone: 886-7-822-5408 or 886-7-822-5410
Fax: 886-7-822-5417
Email: sales@wontop.com
Internet: <http://www.wontop.com>

We power your everyday.