

1.1mm Pitch Low Profile Compression Connectors

DF26 Series

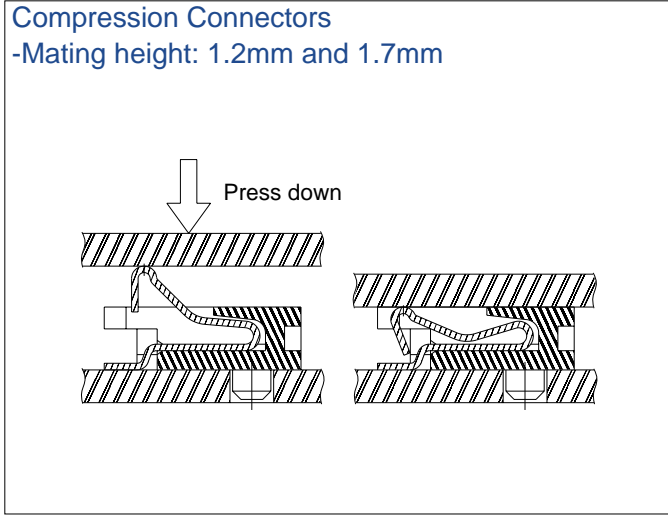
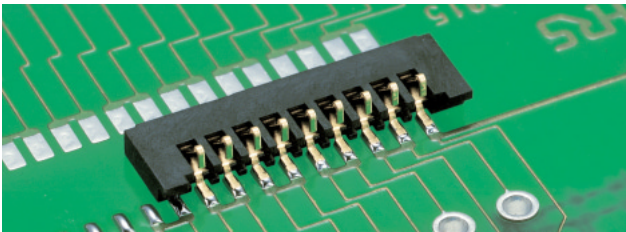
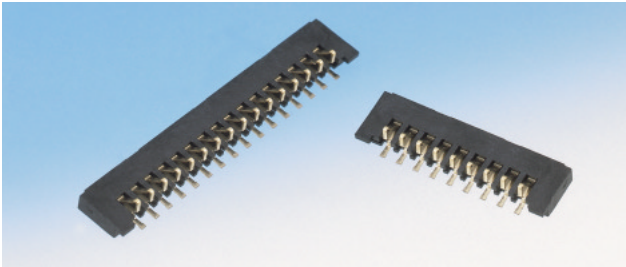

Features

1. Low Profile

Connectors are available in heights : 1.2mm and 1.7mm.

2. Miniature, Space-Saving Design

The space-saving design of these connectors permits increase in the mounting density as compared to equivalent products.

3. One-Piece Connector

These connectors support cost reduction requirement since there is no need for a mating half connector. This design also permits a reduction in the number of assembly steps.

4. Variations

Number of Contacts	9 Contacts	16 Contacts	18 Contacts
Mating Height			
1.2mm	✓	✓	Under development
1.7mm	✓		

Applications

LCD, cellular phones, notebook computers, miniature office automation equipment, and miniature consumer products.

Product	Item	Before Contact	Contacting (Effective Mating Height)	
			1.55mm	1.2mm
1.2mm	1.9mm			
			1.55mm	1.2mm
1.7mm	2.4mm			
			2.05mm	1.7mm

Product Specifications

Rating	Current rating Voltage rating	0.5 A 50 V AC	Operation Temperature Operation Humidity	-35°C to 85°C (Note 1) 20% to 80%	Storage Temperature Storage Humidity	-10°C to 60°C (Note 2) 40% to 70% (Note 2)
--------	----------------------------------	------------------	---	--------------------------------------	---	---

Item	Specification	Conditions
1. Insulation resistance	500 M ohms min.	100 V DC
2. Withstanding voltage	No flashover or insulation breakdown	150 V AC / one minute
3. Contact resistance	50 m ohms max.	100 mA
4. Vibration	No electrical discontinuity of 1μs or more	Frequency: 10 to 55 Hz, single amplitude of 0.75 mm, 2 hours in each of the 3 directions
5. Humidity	Below the contact resistance standard value. Insulation resistance: 500 M min.	96 hours at temperature of 40 ±2°C and humidity of 90% to 95%
6. Temperature cycle	Below the contact resistance standard value. Insulation resistance: 500 M ohms min.	Temperature: -55°C → +5°C to +35°C → +85°C → +5°C to +35°C Time sequence: 30 → 10 → 30 → 10 (Minutes) 5 cycles
7. Stroke life	Below contact resistance standard value	50 stroke cycles
8. Resistance to soldering heat	No deformation of the insulator parts affecting performance.	Reflow soldering: At recommended temperature profile Manual soldering: Soldering iron temperature 300°C, 3 seconds

Note 1: Includes temperature rise caused by current flow.

Note 2: The term "storage" refers to connectors stored for long period of time prior to mounting and use. Operating Temperature Range and Humidity range covers non- conducting condition of installed connectors in storage, shipment or during transportation.

et4U.com

DataShee

Materials

Item	Part	Material	Finish	Remarks
Compression	Insulator	LCP	Color: Black	UL94V-0
	Contacts	Phosphor bronze	Gold plating	—

Ordering Information

DF26 # 1.2 - * CP - 1.1 V (* *)

① ② ③ ④ ⑤ ⑥ ⑦ ⑧

① Series name: DF26	④ Number of contacts: 9, 16	⑧ Packaging (51): Embossed tape packaging (2,000 pieces per reel) 0.1 micron gold plated (66): Embossed tape packaging (2,000 pieces per reel) 0.5 micron gold plated
② Boss type A: With boss	⑤ Connector type CP: Single row compression	
③ Mating height 1.2: 1.2mm 1.7: 1.7mm	⑥ Contact pitch: 1.1mm ⑦ Contact type V: Straight SMT	

■ Compression Connectors (Straight SMT) for 1.2mm Mating

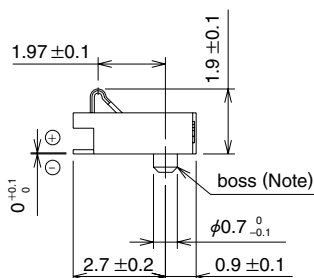
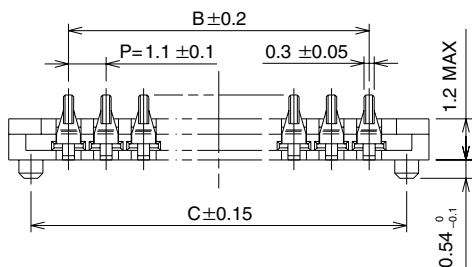
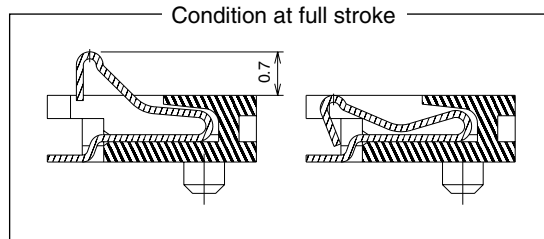
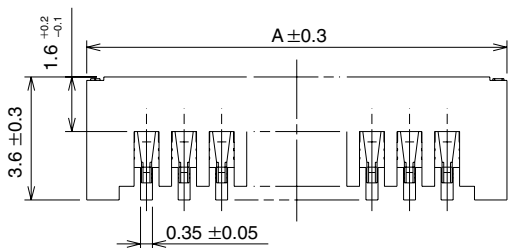

◆ PCB Mounting Pattern

DataSheet4U.com

Connector Mounting Surface Side

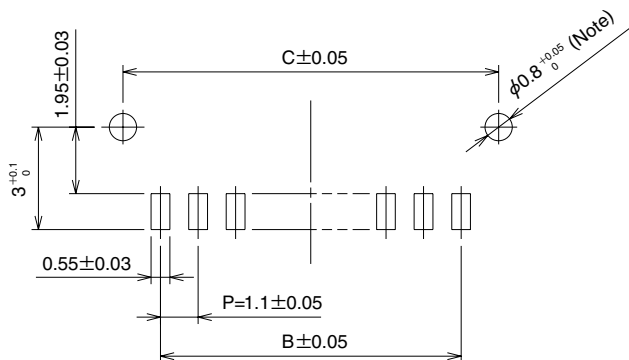

Connector Contact Side

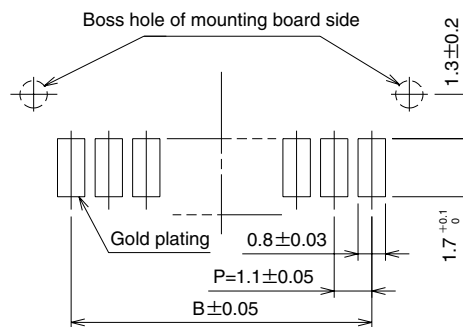

[Specification number] — **, (**)
 (51): Gold plating, embossed tape packaging (2,000 pieces per reel)

Unit: mm

Product No.	HRS No.	Number of Contacts.	A	B	C	Embossed width	Notes
DF26A1.2- 9CP-1.1V(**)	CL661-0002-5-**	9	12.3	8.8	11.0	24	With boss
DF26A1.2-16CP-1.1V(**)	CL661-0003-8-**	16	20.0	16.5	18.7	32	
DF26A1.2-18CP-1.1V(**)	Under development	18	22.2	18.7	20.9	32	

Note: Order by number of reels.

www.DataSheet4U.com

■ Compression Connectors (Straight SMT) for 1.7mm Mating

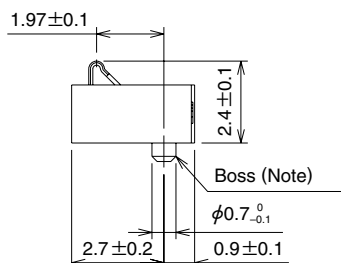
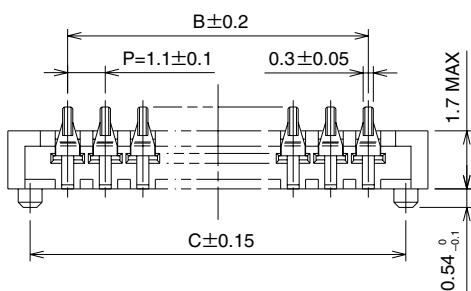
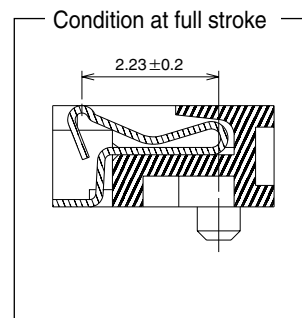
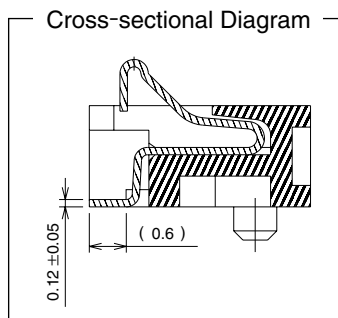
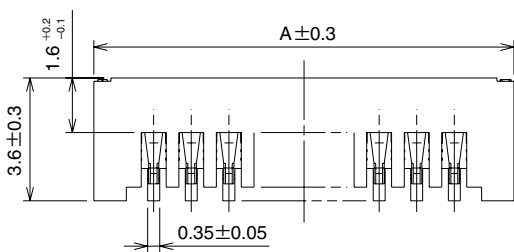

et4U.com

DataShee

◆ PCB Mounting Pattern

DataSheet4U.com

Connector Mounting Surface Side

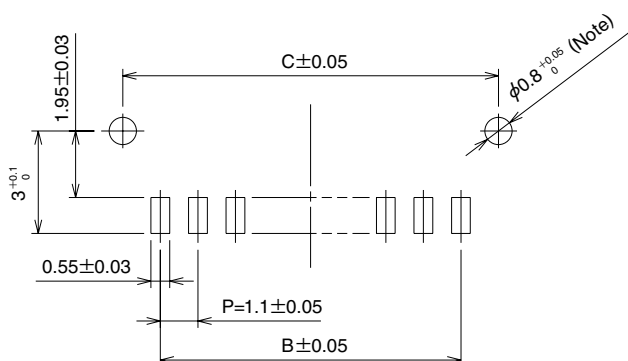

Connector Contact Side

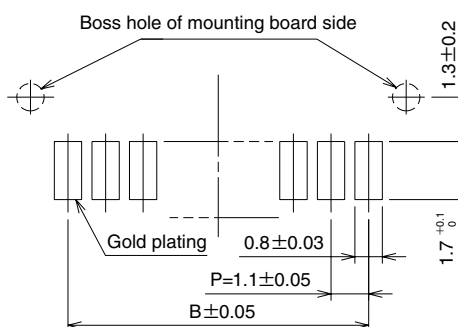

[Specification number] — **, (**)
 (66): Gold plating, embossed tape packaging (2,000 pieces per reel)

Unit: mm

Product No.	HRS No.	Number of Contacts	A	B	C	Embossed width	Notes
DF26A1.7-9CP-1.1V(**)	CL661-0008-1-***	9	12.3	8.8	11.0	24	With boss

Note: Order by number of reels.

DataSheet4U.com

◆ Embossed Carrier Tape Dimensions

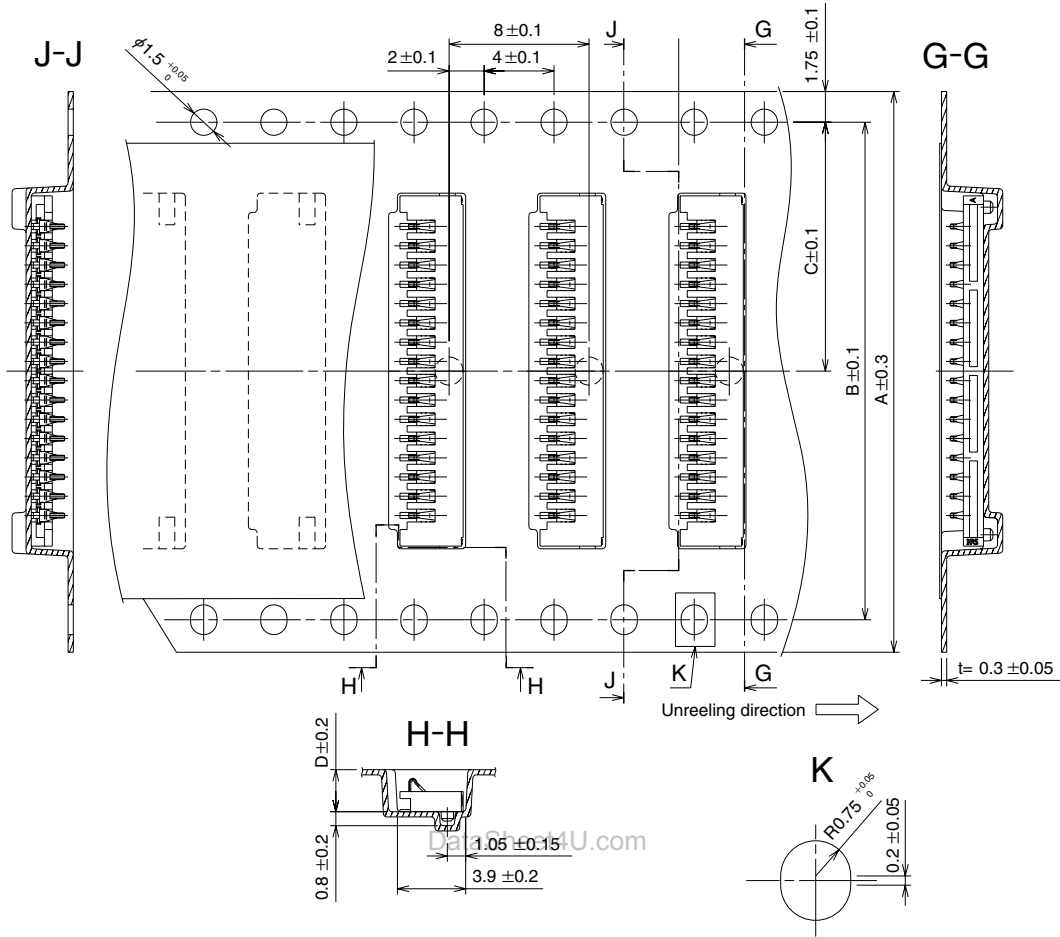

Reel Dimension

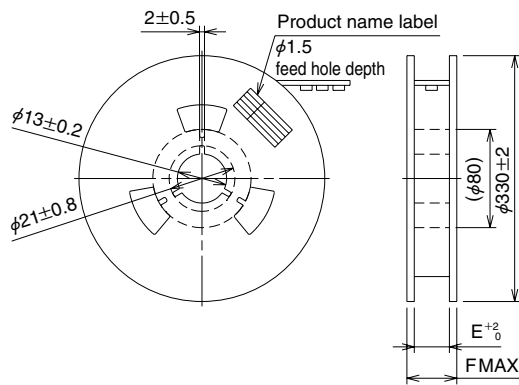

Unit: mm

Product No.	Number of Contacts	A	B	C	D	E	F	Notes
DF26A1.2- 9CP-1.1V	9	24	—	11.5	2.4	24.4	30.4	With boss
DF26A1.2-16CP-1.1V	16	32	28.4	14.2	2.4	32.4	38.4	
* DF26A1.2-18CP-1.1V	18	32	28.4	14.2	2.4	32.4	38.4	
DF26A1.7- 9CP-1.1V	9	24	—	11.5	2.9	24.4	30.4	

* Under development

◆ Precautions for Use

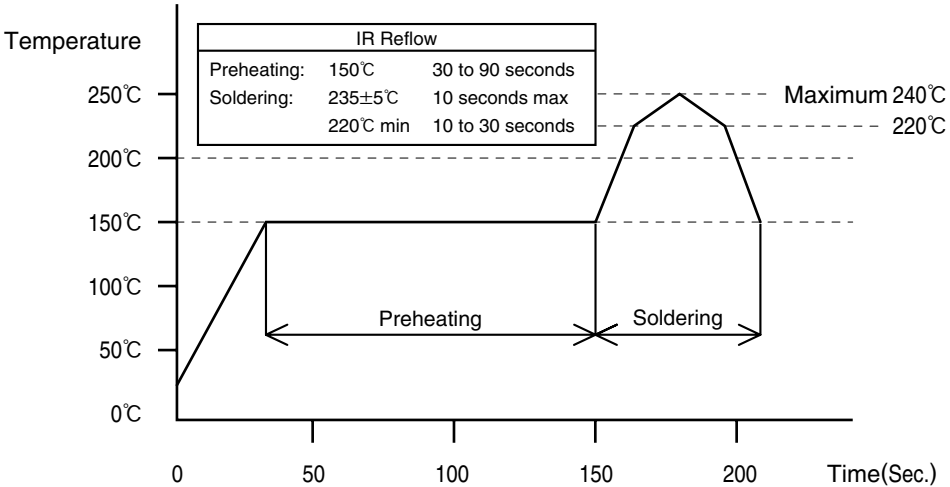
<p>1. Recommended Temperature Profile</p>	 <p>The graph shows a temperature profile for IR reflow. The y-axis is Temperature (0°C to 250°C) and the x-axis is Time (Sec.) (0 to 200). The profile starts at 0°C, rises to 150°C at 30 seconds, holds at 150°C for 90 seconds (Preheating), then rises to a peak of 240°C, holds at 240°C for 10 seconds (Soldering), and then cools down. A dashed line indicates a 220°C minimum temperature during the soldering phase.</p> <table border="1" data-bbox="706 308 1104 436"> <thead> <tr> <th colspan="3">IR Reflow</th> </tr> </thead> <tbody> <tr> <td>Preheating:</td> <td>150°C</td> <td>30 to 90 seconds</td> </tr> <tr> <td>Soldering:</td> <td>235±5°C</td> <td>10 seconds max</td> </tr> <tr> <td></td> <td>220°C min</td> <td>10 to 30 seconds</td> </tr> </tbody> </table> <p>Note1: Up to 2 cycles of reflow soldering are possible under the same conditions, provided that there is a return to normal temperature between the first and second cycle.</p> <p>Note2: The temperature profile indicates the board surface temperature at the point of contacts with the connector terminals (for surface mounted receptacle).</p>	IR Reflow			Preheating:	150°C	30 to 90 seconds	Soldering:	235±5°C	10 seconds max		220°C min	10 to 30 seconds
IR Reflow													
Preheating:	150°C	30 to 90 seconds											
Soldering:	235±5°C	10 seconds max											
	220°C min	10 to 30 seconds											
<p>2. Recommended manual soldering</p>	<p>Manual soldering: 290±10°C for 3 seconds</p>												
<p>3. Recommended screen thickness</p>	<p>0.15mm DataSheet4U.com</p>												
<p>4. Board warpage</p>	<p>Maximum of 0.03mm at the connector center, with both ends of the connector as reference points.</p>												
<p>5. Cleaning conditions</p>	<p>Refer to "Nylon connector Use Handbook".</p>												
<p>6. Precautions</p>	<ul style="list-style-type: none"> ■ Excessive twisting when mating/un-mating may cause damage to the connector. ■ The contacts are of an exposed design and touching them with bare hands may cause breakdown of the elements due to contact faults or static electricity. 												