



DF319

3-Phase Brushless DC Motor Controller

Data Sheet

Version 0.01 – Oct. 30, 2018

Copyright © 2018 by PADAUK Technology Co., Ltd. all rights reserved.

6F-6, No. 1, Sec. 3, Gongdao 5th Road, Hsinchu 30069, Taiwan, R.O.C.

TEL: 886-3-572-8688  www.padauk.com.tw

IMPORTANT NOTICE

PADAUK Technology reserves the right to make changes to its products or to terminate production of its products at any time without notice. Customers are strongly recommended to contact PADAUK Technology for the latest information and verify whether the information is correct and complete before placing orders.

PADAUK Technology products are not warranted to be suitable for use in life-support applications or other critical applications. PADAUK Technology assumes no liability for such applications. Critical applications include, but are not limited to, those which may involve potential risks of death, personal injury, fire or severe property damage.

PADAUK Technology assumes no responsibility for any issue caused by a customer's product design. Customers should design and verify their products within the ranges guaranteed by PADAUK Technology. In order to minimize the risks in customers' products, customers should design a product with adequate operating safeguards.

Table of Contents

1. Key Features	5
2. DF319 Pin Assignment and Description	6
3. DC Characteristics	7
3.1. Absolute Maximum Ratings	7
4. Block Diagram	8
5. Functional Description	8
5.1. Main Control.....	8
5.2. Current Detector	8
5.3. Motor Sequence Control.....	8
5.4. Position Detector	9
5.5. Interface	9
6. Application Diagram	9
6.1. Reference Application Circuit	10
7. Package Marking Information	11
7.1. Marking Information	11
7.2. SSOP16 IC Drawing	12

Revision History:

Revision	Date	Description
0.00	2017/4/25	Preliminary version
0.01	2018/10/30	1. Updated company address & Tel No. 2. Amend Section 7.1 Marking Information

1. Key Features

- Support 3-Phase brushless DC motor with hall IC interface
- Support PWM control input or voltage control input
- Support FG/RD/ALM/RALM/RXX/RRXX output
- Support close loop control and open loop control
- Support current limitation and current protection
- Support soft-start
- Support lock-protect and auto-restart
- Built-in internal RC clock oscillator
- 5V operating voltage

2. DF319 Pin Assignment and Description

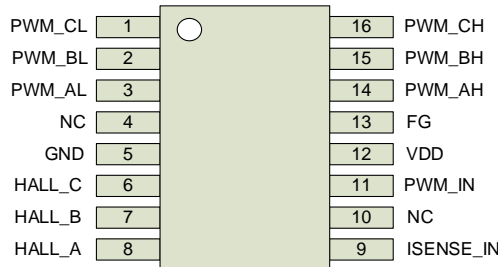

SSOP16 Pin No.	Pin Name	I/O	Description
1	PWM_CL	Output	C output signal to control the low side of motor driver
2	PWM_BL	Output	B output signal to control the low side of motor driver
3	PWM_AL	Output	A output signal to control the low side of motor driver
4	NC	-	No connection
5	GND	-	Ground
6	HALL_C	Input	Digital input to sense motor position C
7	HALL_B	Input	Digital input to sense motor position B
8	HALL_A	Input	Digital input to sense motor position A
9	ISENSE_IN	Input	Analog input to sense motor current
10	NC	-	No connection
11	PWM_IN	Input	PWM control input
12	VDD	-	Power
13	FG	Output	Rotation speed detection
14	PWM_AH	Output	A output signal to control the high side of motor driver
15	PWM_BH	Output	B output signal to control the high side of motor driver
16	PWM_CH	Output	C output signal to control the high side of motor driver

3. DC Characteristics

Symbol	Description	Min.	Typ	Max.	Unit	Conditions (Ta=25 °C)
V _{DD}	Operating Voltage	4.75	5.0	5.25	V	
I _{OP}	Operating Current		10		mA	
V _{IL}	Input low voltage for IO lines	0		0.3V _{DD}	V	
V _{IH}	Input high voltage for IO lines	0.7 V _{DD}		V _{DD}	V	
I _{OL}	IO lines sink current		10		mA	V _{DD} =5.0V, V _{OL} =0.5V
I _{OH}	IO lines drive current		-7		mA	V _{DD} =5.0V, V _{OH} =4.5V
R _{PH}	Pull-high Resistance		100		KΩ	V _{DD} =5.0V
V _{BRD}	Brown-out Detect Voltage		3.5		V	After DF319 configuration
V _{POR}	Power-On Reset Voltage		2		V	
θ _{ja}	Thermal resistance from junction to ambient		75		°C/W	
θ _{jc}	Thermal resistance junction to top of case		25		°C/W	

3.1. Absolute Maximum Ratings

- Supply Voltage 4.75V ~ 5.25V
- Input Voltage -0.3V ~ V_{DD} + 0.3V
- Operating Temperature -20 °C ~ 70 °C
- Storage Temperature -50 °C ~ 125 °C

4. Block Diagram

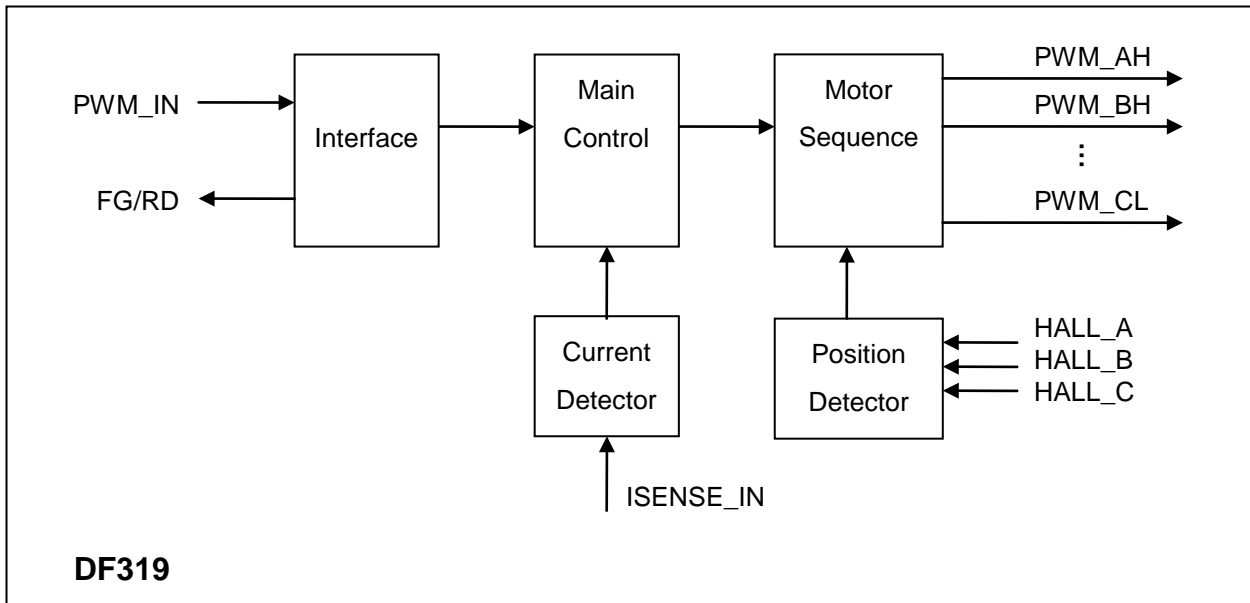

5. Functional Description

DF319 is a controller which is target for 3-phase brushless DC motor with hall sensor; there are five functional modules inside the DF319: Main Control, Current Detector, Motor Sequence Control, Position Detector and Interface. Its functional descriptions are shown as below:

5.1. Main Control

This Main Control module is coordinator to maintain the finite state of the system. It receives the command passed by user interface detector and motor current from current detector module, and then determines the next action for motor based on those two received conditions.

5.2. Current Detector

This module is used to detect the feedback current of motor (ISENSE_IN) and send to main control module, the main control will stop the motor whenever the sensing current reaches the value corresponding to over current protection.

5.3. Motor Sequence Control

The motor sequence control module controls the power MOSFET ON/OFF of motor. It depends on the position information sent by position detector module to output the six driving signals (PWM_AH, PWM_AL, PWM_BH, PWM_BL, PWM_CH, and PMW_CL) that can be directly associated to the sequence phase of motor.

5.4. Position Detector

This module is used to detect the feedback hall signals of motor (HALL_A, HALL_B, and HALL_C) and send to motor sequence control module, the sequence control module will decide the next sequence phase to drive the motor.

5.5. Interface

This module is used to detect the user interface, including PWM input and FG output.

6. Application Diagram

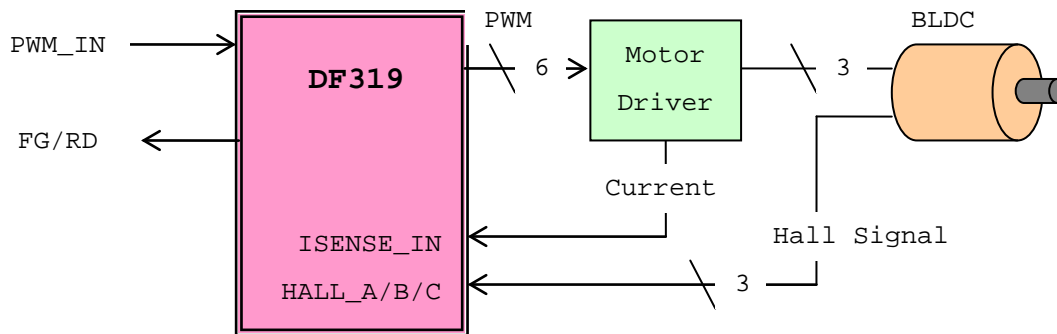

6.1. Reference Application Circuit

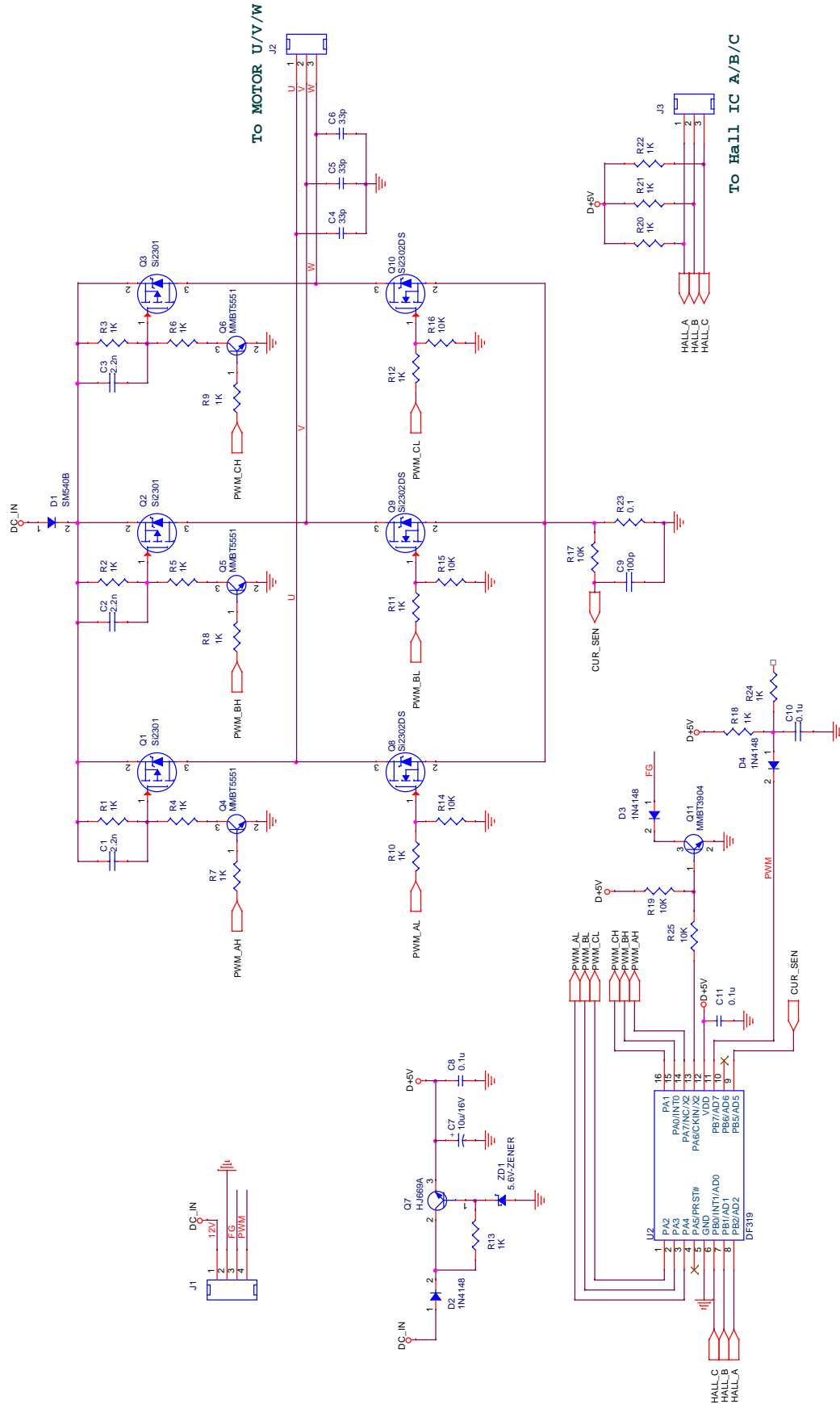

7. Package Marking Information

7.1. Marking Information

SSOP16

Example: blank

Example: code

P P P P C C C C S S S S S S S S y y w w V X A 
--

D F 3 1 9 P D F F H J 0 2 3 5 1 1 8 4 8 A B K 
--

D F 3 1 9 A 0 0 1 H Q 1 2 3 4 5 1 8 5 0 A B K 
--

Project Legend	
P P P P	Product name (Ex: DF319)
C C C C	Customer's production code number (If blank that CCCC will be PDFF.)
y y	Year code (last 2 digits of calendar year)
w w	Week code
V	Vender code
X	Serial number
A	Wafer information

7.2. SSOP16 IC Drawing

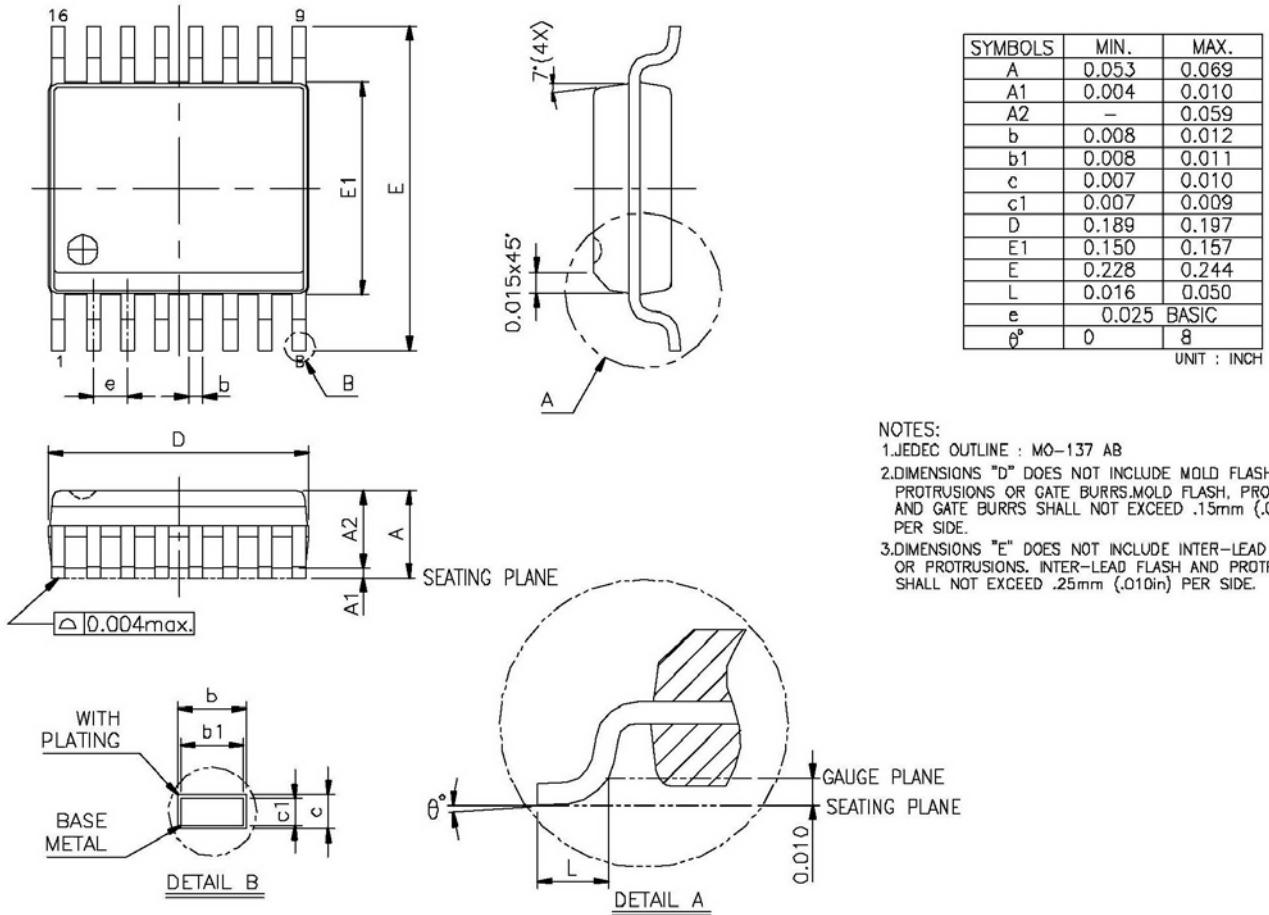

- NOTES:
- JEDEC OUTLINE : MO-137 AB
 - DIMENSIONS "D" DOES NOT INCLUDE MOLD FLASH, PROTRUSIONS OR GATE BURRS. MOLD FLASH, PROTRUSIONS AND GATE BURRS SHALL NOT EXCEED .15mm (.006in) PER SIDE.
 - DIMENSIONS "E" DOES NOT INCLUDE INTER-LEAD FLASH, OR PROTRUSIONS. INTER-LEAD FLASH AND PROTRUSIONS SHALL NOT EXCEED .25mm (.010in) PER SIDE.