

4 GHz 1550 nm Directly Modulated DFB Laser

The Optilab DFB-DM-1550-4 directly-modulated (DM) DFB laser is a cost-effective solution for 4 GHz analog or 2.5 Gb/s digital transmission.

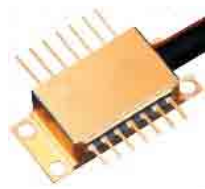

DFB-DM-1550-4 4 GHz 1550 nm DM DFB Laser

Product Description

The Optilab DFB-DM-1550-4 directly-modulated (DM) DFB laser is a cost-effective solution for 4 GHz analog or 2.5 Gb/s digital transmission of up to 100 km using traditional SMF-28 single-mode fiber. The laser is available in DWDM ITU-T grid wavelengths between 1546 nm and 1550 nm. The MQW DFB laser features 10 mW of output optical power, low residual chirp, and a built-in thermoelectric cooler, thermistor, and a rear-facet monitor photodiode for external optical power control.

Features

- 4 GHz analog bandwidth
- 2.5 Gb/s digital transmission
- 100 km SM fiber transmission
- Available in DWDM ITU-T wavelength between 1546 nm and 1550 nm
- 10mW Output Power
- Built-in TEC, Thermistor & Monitor PD

Applications

- 2.5 Gbps long haul communication
- Analog Link up to 4 GHz bandwidth
- 100 km transmission

PRODUCT SPECIFICATIONS

Technical Specifications

Wavelength Range	1546 nm to 1551 nm
Optical Output Power	10.0 mW min.
Threshold Current	30 mA typ. @ CW
Laser Set Temperature	20 °C min., 35 °C max.
Forward Voltage	1.6 V typ.
Series Resistance	25 Ω typ.
Slope Efficiency	01.4 mW/mA
Threshold Power	150 μ W
Tracking Error (Note 1)	-0.5 dB min.
Monitor Current	0.10 mA min., 1.0 mA max.
Photodiode Dark Current	2 nA typ., 100 nA max.
Photodiode Capacitance	10 pF max.
Photodiode Cutoff	100 MHz min.
Side Mode Suppression	35 dB typ.
Spectral Width (-20dB)	0.5 nm max.
Rise Time (10%-90%)	0.1 nsec typ.
Fall Time (10%-90%)	0.1 nsec typ.
Cutoff Frequency	4.0 GHz
In-Band Ripple (Window)	\pm 1.5 dB
RF Return Loss	6 dB from 2 to 3 GHz 3 dB 3 GHz and up
Optical Isolation	35 dB typ.
Relative Intensity Noise	-140 dB/Hz
Kinks (up to 2.4mW)	None
Pulsation	None
BER Performance	No Floor
Power Penalty	1.5 dB max.

Ordering Information

DFB-DM-1550-4-xxxx-yy

xxxx	DFB Wavelength Connector Type
yy	FA, FC/APC SU, SC/UPC

Frequency Response

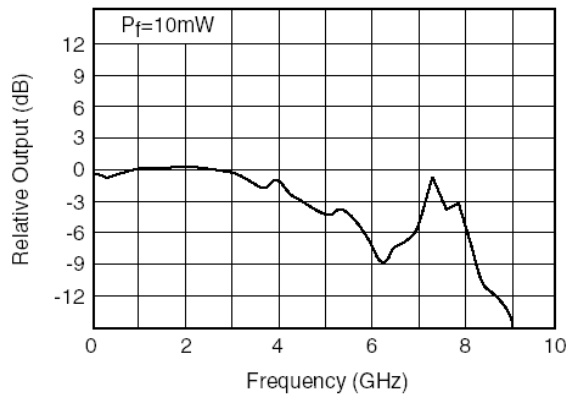

RF Return Loss

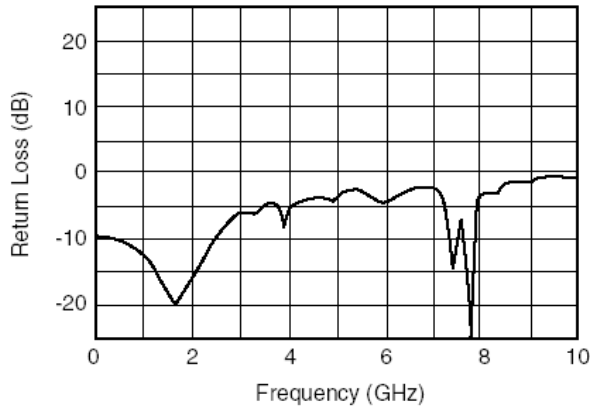

Mechanical Dimensions

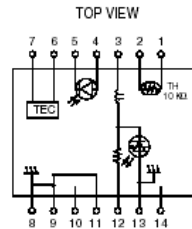
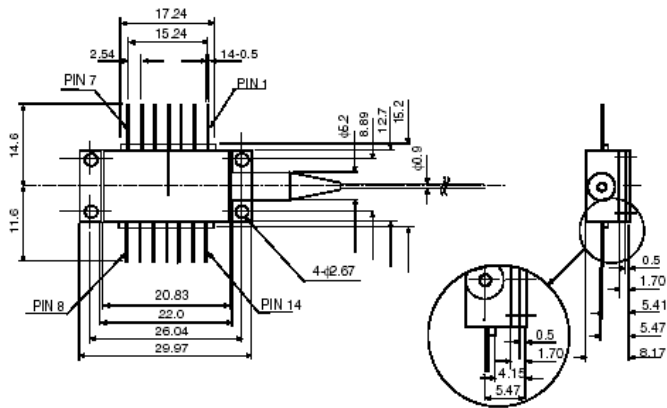

PIN #	FUNCTION
1.	Temperature Monitor
2.	Temperature Monitor
3.	Laser DC Bias (-)
4.	Monitor (Anode)
5.	Monitor (Cathode)
6.	TEHP (+)
7.	TEHP (-)
8.	Case Ground
9.	Case Ground
10.	N.C.
11.	Laser Ground
12.	Laser Modulation (-)
13.	Case Ground
14.	N.C.

*Pigtail length (L) shall be specified in the detail (individual) specification, if it is special.
L=1500 min. for standard

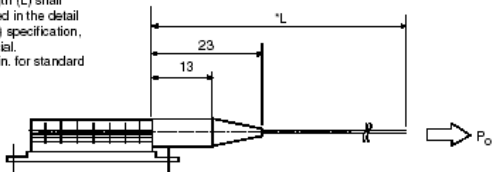

4 GHz 1550 nm Directly Modulated DFB Laser

Absolute Maximum Ratings

Operating Temperature	-20 °C to +65 °C
Storage Temperature	-40 °C to +70 °C
Optical Output Power	12.0 mW @ CW
Forward Current	150 mA @ CW
Reverse Voltage	2 V
PD Reverse Voltage	20 V
PD Forward Current	10 mA
TEC Voltage	2.5 V
TEC Current	1.4 A
Lead Soldering Time	10 Sec @ <260°C
Operating Humidity	95% @ <30°C
Storage Humidity	95% @ <30°C

TEC and Thermistor Characteristics

TEC Current	1.0 A max.
TEC Voltage	2.4 V max.
Cooler Power	2.4 W max.
TEC Resistance	2.0 Ω min., 2.4 Ω typ., 3.2 Ω max.
Thermistor Resistance	7.7 k Ω min., 12.6 k Ω max.
Thermistor B Constant	3,270 K min., 3,450 K typ., 3,630 K max.

Mechanical Specifications

Housing Dimensions	30 mm x 15 mm x 8 mm
Housing Type	7-pin Butterfly Package
Optical Connectors	FC/APC, FC/UPC, SC/APC, SC/UPC
Optical Fiber Type	SMF-28 (Standard)