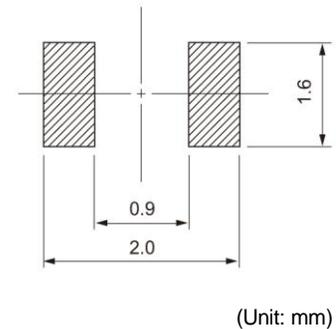
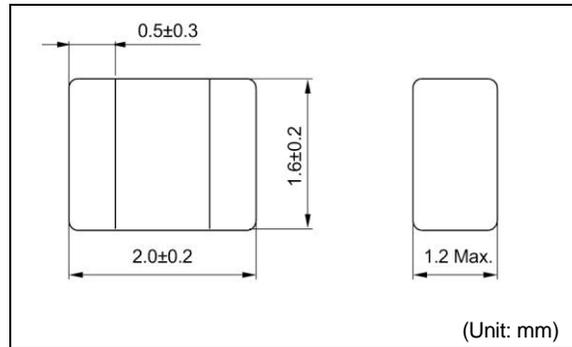
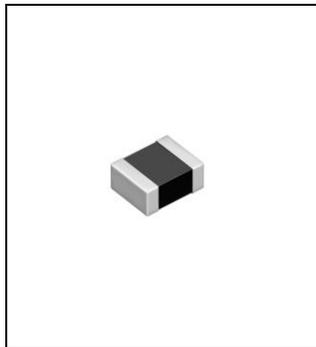

DFE201612R

Inductance Range: 0.47~2.2μH

Recommended patterns
 推奨パターン図

FEATURES 特長

- Miniature size: 2016 footprint (2.0mm×1.6mm) and low profile(1.2mm Max. height)
- The use of magnetic iron powder ensure capability for large current.
- The use of Flat wire for Low DC resistance.
- Magnetically shielded, low audible core noise.
- Reflow solderable.
- Operating temperature : -40~+85°C
- 小型薄型構造 (2.0 x 1.6mm角、高さ1.2mm Max.)
- 磁性材に鉄系磁性粉を用いた大電流対応
- 平角線採用による低直流抵抗
- 閉磁路構造、低コア鳴きノイズ
- リフロはんだ対応
- 動作温度範囲 : -40~+85°C

STANDARD PART NUMBERS 標準品一覧

TYPE DFE201612R (Quantity/reel; 3,000 PCS)

品番	インダクタンス ⁽¹⁾	許容差	測定周波数	直流抵抗 ⁽²⁾	直流重畳許容電流 ⁽³⁾	温度上昇許容電流 ⁽⁴⁾
Part Number	Inductance ⁽¹⁾ (μH)	Tolerance (%)	Test Frequency (MHz)	DC Resistance ⁽²⁾ (mΩ) Max. (Typ.)	Inductance Decrease Current ⁽³⁾ (A) Max. (Typ.) $\frac{\Delta L}{L} = 30\%$	Temperature Rise Current ⁽⁴⁾ (A) Max. (Typ.) ΔT=40°C
DFE201612R-H-R47M=P2	0.47	±20	1	40 (29)	3.5 (4.4)	3.2 (3.8)
DFE201612R-H-1R0M=P2	1.0	±20	1	70 (54)	2.6 (3.3)	2.6 (3.0)
DFE201612R-H-1R5M=P2	1.5	±20	1	94 (78)	2.1 (2.6)	2.0 (2.4)
DFE201612R-H-2R2M=P2	2.2	±20	1	154 (128)	1.7 (2.1)	1.4 (1.7)

(1) Inductance is measured with a LCR meter 4284A (Agilent Technologies) or equivalent. Test frequency at 1MHz

(2) DC resistance is measured with 34420A (Agilent Technologies) or 3541 (HIOKI). (Reference ambient temperature 20°C)

(3) Inductance Decrease Current based upon 30% inductance reduction from the initial value

(4) Temperature Rise Current based upon 40°C temperature rise. (Reference ambient temperature 20°C)

(1) インダクタンスはLCRメータ4284A (Agilent Technologies) または同等品により測定する。測定周波数は1MHz。

(2) 直流抵抗は測定器34420A (Agilent Technologies) または3541 (HIOKI) と同等品により測定する。(周囲温度20°C)

(3) 直流重畳許容電流 : 直流重畳電流を流した時インダクタンスの値が初期値より30%減少する直流電流値

(4) 温度上昇許容電流 : コイルの温度が40°C上昇する値 (周囲温度20°Cを基準とする。)