

### Features

- Wide viewing angle, top view SMT LED
- Extended operating temperature range from -40 to +100°C
- PLCC-2 package
- Available on EIAJ standard ETX-7001 reels

### Applications

- Indicator for automotive instrument panel, back-lighting for radio or A/C control panels

### Outline Dimensions

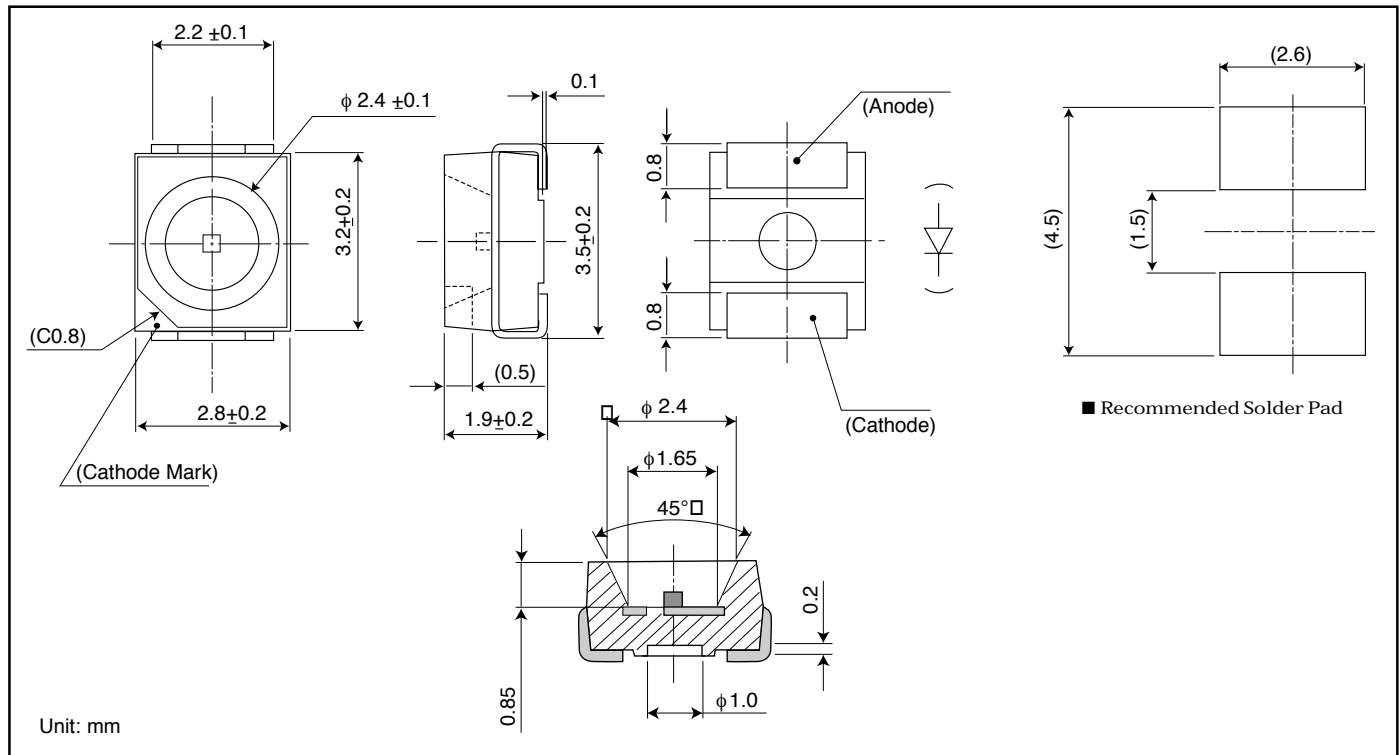

### Electro-Optical Characteristics

(Ta=25°C)

Part No.	Material	Emitted Color	Lens Color	Luminous Intensity I <sub>v</sub>			Wavelength				Forward Voltage V <sub>F</sub>			Reverse Current I <sub>R</sub>		Viewing Angle (2 θ 1/2)
				MIN.	TYP.	I <sub>F</sub>	Peak λ <sub>p</sub> TYP.	Dominant λ <sub>d</sub> TYP.	Spectral Line Half Width Δλ TYP.	I <sub>F</sub>	TYP.	MAX.	I <sub>F</sub>	MAX.	V <sub>R</sub>	
FR1104B	AllnGap	Red	Water Clear	35	70	20	645	632	15	20	2.0	2.5	20	100	5	120°
FA1104B	AllnGap	Orange		35	70	20	609	605	15	20	2.0	2.5	20	100	5	
FY1104B	AllnGap	Yellow		35	70	20	588	587	15	20	2.0	2.5	20	100	5	
BG1104B	GaP	Pure Green		5	10	20	555	557	30	20	2.1	2.5	20	100	4	
DG1104B	InGaN/SiC	Green		60	120	20	518	525	30	20	3.5	4.0	20	100	5	
DC1104B	InGaN/SiC	Bluish-Green		60	120	20	502	505	30	20	3.5	4.0	20	100	5	
DB1104B	InGaN/SiC	Blue		25	50	20	468	470	30	20	3.5	4.0	20	100	5	
Units				mcd	mA		nm			mA	V	mA	μA	V	Deg.	

## Absolute Maximum Ratings

(Ta=25°C)

Item	Symbol	Red	Orange	Yellow	Pure Green	Green	Bluish-Green	Blue	Units
		FR	FA	FY	BG	DG	DC	DB	
Power Dissipation	Pd	81	81	81	125	80	80	80	mW
Forward Current	I <sub>F</sub>	30	30	30	50	20	20	20	mA
Peak Forward Current	I <sub>FM</sub>	100	100	100	125	50	50	50	mA
Reverse Voltage	V <sub>R</sub>	5	5	5	4	5	5	5	V
Operating Temperature	Topr	-40 to +100							°C
Storage Temperature	Tstg	-40 to +110							°C
Derating	ΔI <sub>F</sub>	0.75 (60°C ~ 100°C)			1.0 (50°C ~ 100°C)	0.5 (60°C ~ 100°C)			mA/°C

- Ta=25°C
- I<sub>FM</sub> applies for the pulse width ≤ 1msec. and duty cycle ≤ 1/20.

## Operation Current Derating Chart

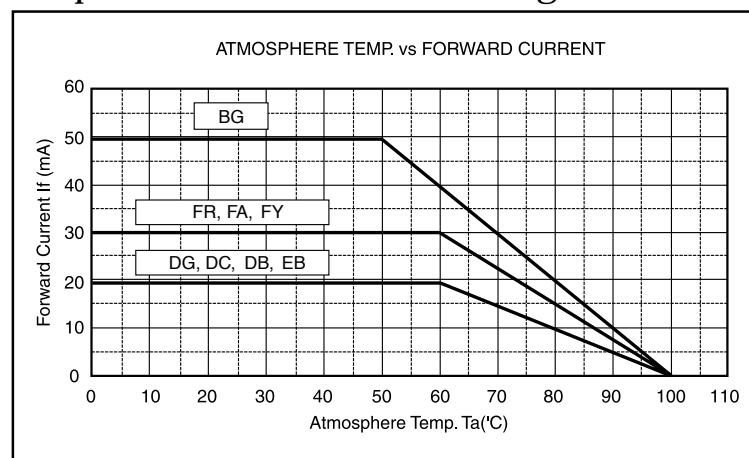

## Spatial Distribution

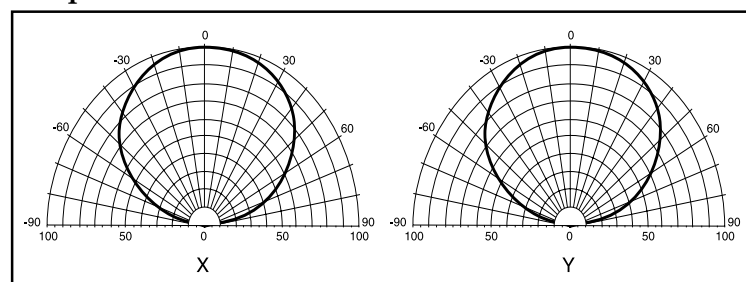

## Taping Specifications

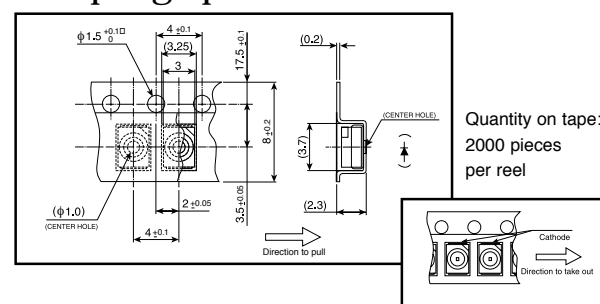

## Precautions

Please follow these handling precautions to prevent damage to the chip and ensure its reliability.

### 1. Soldering conditions:

- **Soldering iron:** Temperature at tip of iron: 280°C max. (30W max.) Soldering time: 3 sec. max.
- **Dip soldering:** Preheating: 100°C max. (resin surface temp.) 60 sec. max. Bath temperature: 260°C max. Dipping Time: 5 sec. max.
- **Reflow Soldering:**

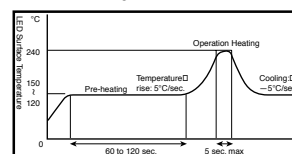

### 2. Cleaning:

- If cleaning is required, use the following solutions for less than 1 minute, at less than 40°C.
- Appropriate chemicals: Ethyl alcohol and isopropyl alcohol.
- Effect of ultrasonic cleaning on the LED resin body differs depending on such factors as the oscillator output, size of PCB and LED mounting method. The use of ultrasonic cleaning is strongly recommended after confirming there is no problem.

Product specifications subject to change without notice. PG1104B-0301