



DG24064

240 x 64 Dots

■Mechanical Data			■Absolute Maximum Ratings					
Item	Standard Value	Unit	Item	Symbol	Standard Value			Unit
					Min.	Typ.	Max.	
Module Size	180.0(W) x 65.0(H) x 10.0(T)	mm	Supply Voltage for Logic	$V_{dd}-V_{ss}$	-0.3	--	7.0	V
Viewing Area	132.0(W) x 39.0 (H)	mm	Supply Voltage for LCD Drive	$V_{dd}-V_{ee}$	-0.3	--	28.0	V
Dot Pixels	240 x 64	dots	Input Voltage	V_i	-0.3	--	$V_{dd}+0.3$	V
Dot Size	0.49 x 0.49	mm	Operation Temperature	T_{opr}	0	--	50	°C
Dot Pitch	0.53 x 0.53	mm	Storage Temperature	T_{stg}	-20	--	60	°C

■Electrical Characteristics

Item	Symbol	Condition	Specification	Unit
Logic circuit power supply Voltage	V_{DD}	--	4.75 \Rightarrow 5.25	V
	V_0	--	-5.0 \Rightarrow 20.0	
EL driver voltage	V_{EL}	fEL=500Hz	90 \Rightarrow 110	V
High Level input voltage	V_{IH}	$V_{DD} = 5 \pm 0.25$	(0.7 \Rightarrow 1.0) x V_{DD}	V
Low Level input voltage	V_{IL}	$V_{DD} = 5 \pm 0.25$	(0 \Rightarrow 0.3) x V_{DD}	V
High Level output voltage	V_{OH}	$V_{DD} = 5 \pm 0.25$	2.4 $\Rightarrow V_{DD}$	V
Low Level output voltage	V_{OL}	$V_{DD} = 5 \pm 0.25$	0 \Rightarrow 0.4	V
Current consumption	I_{DD}	$V_{DD} = 5V$	15.0 MAX	mA
	I_{EE}	$V_{EE} = -10V$	2.0 MAX	
	I_{EL}	$V_{EL} = 110V$ fEL = 500Hz	20.0(AC) MAX	

■Pin Assignment

No.	Symbol	Level	Function
1.	V_{SS}		Ground
2.	V_{DD}		Power supply for logic circuit
3.	V_0		Power supply for LCD
4.	RS	H/L	H - Instruction L - Data
5.	R/W	H/L	H: Data read L: Data write
6.	E	H/L	Enable
7-14	DB0-DB7		Data bus line
15	CS		Chip enable active "L"
16	RES		Reset active "L"
17	V_{EE}		Negative voltage output(-10v)
18-20	NC		

■Block Diagram

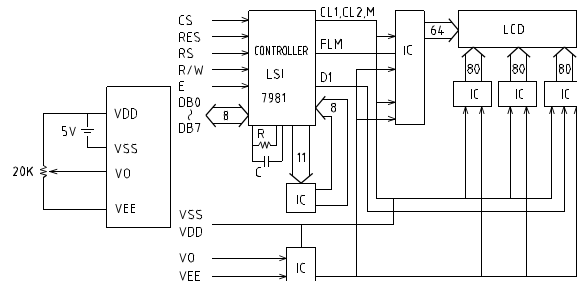

■External Dimensions

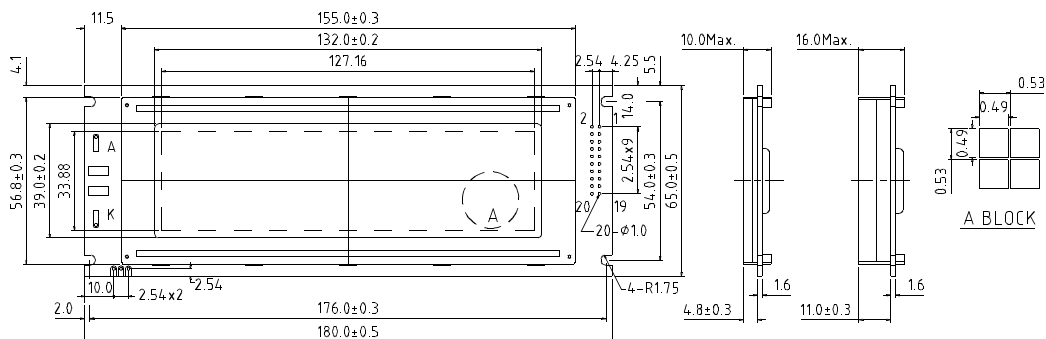

Ref,EL,B/L LED,B/L