



Precision 8-Ch/Dual 4-Ch/Triple 2-Ch Low Voltage Analog Switches/Multiplexers

DESCRIPTION

The DG9051/9052/9053 are low-voltage monolithic CMOS analog switches and multiplexers. DG9051 is an 8-channel multiplexer; DG9052 is a dual 4-channel multiplexer; and DG9053 is a triple single-pole/double throw (SPDT) switch.

They are designed to operate from a +2.7 to +12-V single supply or ± 2.7 to ± 6 -V dual power supplies. All control logic inputs have guaranteed 2-V logic high/0.8-V logic low when operating from a single 5 V or dual ± 5 -V supplies, and 2.4-V logic high/0.8-V logic low when $V_{+} = 12$ V.

Built on Vishay Siliconix's proprietary high-density process, the DG9051/9052/9053 offer the advantage of bi-directional signal, rail to rail analog signal handling.

As a committed partner to the community and the environment, Vishay Siliconix manufactures this product with the Lead (Pb)-Free device terminations. For analog switching products manufactured with 100 % matte tin device termination, the Lead (Pb)-Free "-E3" suffix is being used as a designator.

FEATURES

- 2.7 to 12-V Single Supply or ± 2.7 to ± 6 -V Dual Supply Operation
- Guaranteed Ron Matching
- Low Voltage CMOS Logic Compatible



RoHS
COMPLIANT

BENEFITS

- Wide Operation Voltage Range
- Pin Compatible with 74HC4051/2/5
- Guaranteed Low Leakage

APPLICATIONS

- Battery Powered Equipment
- Test Process Equipment
- Communication Systems
- A/V and Mixed Signal Routing
- Automotive

FUNCTIONAL BLOCK DIAGRAM AND PIN CONFIGURATION

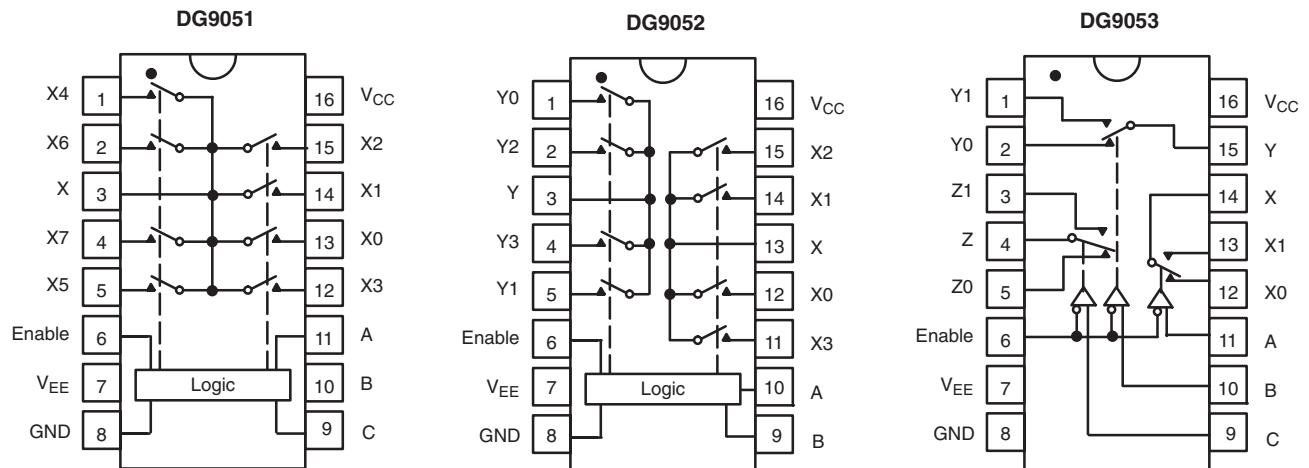

ORDERING INFORMATION

Temp Range	Package	Part Number
-40 to 85°C	TSSOP-16	DG9051DQ-T1-E3
		DG9052DQ-T1-E3
		DG9053DQ-T1-E3

The information shown here is a preliminary product proposal, not a commercial product data sheet. Siliconix is not committed to produce this or any similar product. This information should not be used for design purposes, nor construed as an offer to furnish or sell such products

DG9051/9052/9053

Vishay Siliconix

New Product

TRUTH TABLE						
Enable Input	Select Inputs			On Switches		
	C*	B	A	DG9051	DG9052	DG9053
H	X	X	X	All switches open	All switches open	All switches open
L	L	L	L	X – X0	X – X0, Y – Y0	X – X0, Y – Y0, Z – Z0
L	L	L	H	X – X1	X – X1, Y – Y1	X – X1, Y – Y0, Z – Z0
L	L	H	L	X – X2	X – X2, Y – Y2	X – X0, Y – Y1, Z – Z0
L	L	H	H	X – X3	X – X3, Y – Y3	X – X1, Y – Y1, Z – Z0
L	H	L	L	X – X4	X – X0, Y – Y0	X – X0, Y – Y0, Z – Z1
L	H	L	H	X – X5	X – X1, Y – Y1	X – X1, Y – Y0, Z – Z1
L	H	H	L	X – X6	X – X2, Y – Y2	X – X0, Y – Y1, Z – Z1
L	H	H	H	X – X7	X – X3, Y – Y3	X – X1, Y – Y1, Z – Z1

X = Don't care

ABSOLUTE MAXIMUM RATINGS $T_A = 25\text{ }^\circ\text{C}$, unless otherwise noted				
Parameter		Symbol	Limit	Unit
Voltage Referenced to V–	V+		13.5	V
	GND		7	
Digital Inputs ^a	V _S , V _D		(V–) –0.3 to (V+) +0.3	
Current (Any Terminal Except S or D)			30	mA
Continuous Current, S or D			100	
Peak Current, S or D (Pulsed at 1 ms, 10 % Duty Cycle Max)			200	
Package Solder Reflow Conditions ^b	IR/Convection		260	°C
Storage Temperature			–65 to 150	
Power Dissipation (Packages) ^c	$T_A = 70\text{ }^\circ\text{C}$, TSSOP-16 ^d		925	mW



SPECIFICATIONS (SINGLE SUPPLY 12 V)							
Parameter	Symbol	Test Condition Otherwise Unless Specified $V_+ = 12\text{ V}, \pm 10\%$, $V_- = 0\text{ V}$ $V_A, \overline{V_{EN}} = 0.8\text{ V}$ or 2.4 V^f	Temp ^b	Limits -40 to 85°C			Unit
				Min ^c	Typ ^d	Max ^c	
Analog Switch							
Analog Signal Range ^e	V_{ANALOG}		Full	0		12	V
On-Resistance	r_{ON}	$V_D = 3.5\text{ V}, I_S = 1\text{ mA}$ Sequence Each Switch On	Room Full		30	40 50	Ω
r_{ON} Match Between Channels ⁹	Δr_{ON}	$V_D = 3.5\text{ V}, I_S = 1\text{ mA}$	Room			5	
Switch Off Leakage Current	$I_{S(off)}$	$\overline{V_{EN}} = 2.4\text{ V}, V_D = 11\text{ V}$ or $1\text{ V}, V_S = 1\text{ V}$ or 11 V	Room Full	-1 -20		1 20	nA
	$I_{D(off)}$		Room Full	-1 -20		1 20	
Channel On Leakage Current	$I_{D(on)}$	$\overline{V_{EN}} = 0\text{ V}, V_S = V_D = 1\text{ V}$ or 11 V	Room Full	-2 -10		2 10	
Digital Control							
Logic High Input Voltage	V_{INH}		Full	2.4			V
Logic Low Input Voltage	V_{INL}		Full			0.8	
Input Current	I_{IN}	$V_{AX} = \overline{V_{EN}} = 2.4\text{ V}$ or 0.8 V	Full	-1		1	μA
Dynamic Characteristics							
Transition Time	t_{TRANS}	$V_{NO}/V_{NC} = 8\text{ V}/0\text{ V}, 0\text{ V}/8\text{ V}$ $R_L = 300\ \Omega, C_L = 35\text{ pF}$	Room Full			26 35 55	ns
Break-Before-Make Time	t_{BBM}	$V_{X,Y,Z} = 5\text{ V}, V_S = 0\text{ V},$ $R_L = 306\ \Omega, C_L = 35\text{ pF}$	Room Full	3		10	
Enable Turn-On Time	$t_{ON(\overline{EN})}$		Room Full			20 35 45	
Enable Turn-Off Time	$t_{OFF(\overline{EN})}$		Room Full			16 30 40	
Charge Injection ^e	Q	$C_L = 1\text{ nF}, V_{GEN} = 0\text{ V}, R_{GEN} = 0\ \Omega$	Room			38	pC
Off-Isolation ^{e,h}	OIRR	$f = 1\text{ MHz}, R_L = 50\ \Omega$	Room			-78	dB
Crosstalk ^e	X_{TALK}		Room			-83	
Source Off Capacitance ^e	$C_{S(off)}$	$f = 1\text{ MHz}, V_S = 0\text{ V}, \overline{V_{EN}} = 2.4\text{ V}$	Room			4	pF
Drain Off Capacitance ^e	$C_{D(off)}$	$f = 1\text{ MHz}, V_D = 0\text{ V}, \overline{V_{EN}} = 2.4\text{ V}$	Room			8	
Drain On Capacitance ^e	$C_{D(on)}$	$f = 1\text{ MHz}, V_D = 0\text{ V}, \overline{V_{EN}} = 0\text{ V}$	Room			15	
Power Supply							
Power Supply Current	I+	$\overline{V_{EN}} = V_A = 0\text{ V}$ or V_+	Room			1.0	μA

DG9051/9052/9053

Vishay Siliconix

New Product



SPECIFICATIONS (DUAL SUPPLY $V_+ = 5\text{ V}$, $V_- = -5\text{ V}$)							
Parameter	Symbol	Test Condition Otherwise Unless Specified $V_+ = 5\text{ V}$, $V_- = -5\text{ V} \pm 10\%$ V_A , $V_{\overline{\text{EN}}} = 0.8\text{ V}$ or 2.0 V^f	Temp ^b	Limits -40 to 85°C			Unit
				Min ^c	Typ ^d	Max ^c	
Analog Switch							
Analog Signal Range ^e	V_{ANALOG}		Full	-5		5	V
On-Resistance	r_{ON}	$V_+ = 4.5\text{ V}$, $V_- = -4.5\text{ V}$, $V_D = \pm 3\text{ V}$, $I_S = 1\text{ mA}$ Sequence Each Switch On	Room Full		35	55 60	Ω
r_{ON} Match Between Channels ^g	Δr_{ON}		Room			5	
On-Resistance Flatness ⁱ	r_{ON} Flatness	$V_+ = 4.5\text{ V}$, $V_- = -4.5\text{ V}$, $V_D = \pm 3.0\text{ V}$, $I_S = 1\text{ mA}$	Room		7	10	
Switch Off Leakage Current ^a	$I_{\text{S(off)}}$	$V_+ = 5.5\text{ V}$, $V_- = -5.5\text{ V}$ $V_{\overline{\text{EN}}} = 2.0\text{ V}$, $V_D = \pm 4.5\text{ V}$, $V_S = \pm 4.5\text{ V}$	Room Full	-1 -20		1 20	nA
	$I_{\text{D(off)}}$		Room Full	-1 -20		1 20	
Channel On Leakage Current ^a	$I_{\text{D(on)}}$	$V_+ = 5.5\text{ V}$, $V_- = -5.5\text{ V}$ $V_{\overline{\text{EN}}} = 0\text{ V}$, $V_D = \pm 4.5\text{ V}$, $V_S = \pm 4.5\text{ V}$	Room Full	-2 -10		2 10	
Digital Control							
Logic High Input Voltage	V_{INH}		Full	2.0			V
Logic Low Input Voltage	V_{INL}		Full			0.8	
Input Current ^a	I_{IN}	$V_{\text{AX}} = V_{\text{EN}} = 2.0\text{ V}$ or 0.8 V	Full	-1		1	μA
Dynamic Characteristics							
Transition Time ^e	t_{TRANS}	$V_+ = 4.5\text{ V}$, $V_- = -4.5\text{ V}$, $V_{\text{NO/NC}} = \pm 3\text{ V}$, $R_L = 300\ \Omega$, $C_L = 35\text{ pF}$	Room Full		35	50 65	ns
Break-Before-Make Time ^e	t_{BBM}	$V_{X,Y,Z} = +/ -3\text{ V}$, $V_S = 0\text{ V}$, $R_L = 300\ \Omega$, $C_L = 35\text{ pF}$	Room Full	5	12		
Enable Turn-On Time ^e	$t_{\text{ON}(\overline{\text{EN}})}$		Room Full		38	55 70	
Enable Turn-Off Time ^e	$t_{\text{OFF}(\overline{\text{EN}})}$		Room Full		22	35 50	
Source Off Capacitance ^e	$C_{\text{S(off)}}$	$f = 1\text{ MHz}$, $V_S = 0\text{ V}$, $V_{\overline{\text{EN}}} = 2.0\text{ V}$	Room		5		pF
Drain Off Capacitance ^e	$C_{\text{D(off)}}$	$f = 1\text{ MHz}$, $V_D = 0\text{ V}$, $V_{\overline{\text{EN}}} = 2.0\text{ V}$	Room		9		
Drain On Capacitance ^e	$C_{\text{D(on)}}$	$f = 1\text{ MHz}$, $V_D = 0\text{ V}$, $V_{\overline{\text{EN}}} = 0\text{ V}$	Room		13		
Power Supply							
Power Supply Current	I_+	$V_{\overline{\text{EN}}} = V_A = 0\text{ V}$ or V_+	Room			1.0	μA
	I_-		Room	-1.0			



SPECIFICATIONS (SINGLE SUPPLY 5 V)							
Parameter	Symbol	Test Condition Otherwise Unless Specified $V_+ = 5\text{ V}, \pm 10\%$, $V_- = 0\text{ V}$ $V_A, V_{\overline{EN}} = 0.8\text{ V}$ or 2.0 V^f	Temp ^b	Limits -40 to 85°C			Unit
				Min ^c	Typ ^d	Max ^c	
Analog Switch							
Analog Signal Range ^e	V_{ANALOG}		Full	0		5	V
On-Resistance	r_{ON}	$V_+ = 4.5\text{ V}, V_D$ or $V_S = 3\text{ V}$ or $3.5\text{ V}, I_S = 1\text{ mA}$	Room Full		80	100 120	Ω
r_{ON} Match Between Channels ^g	Δr_{ON}	$V_+ = 4.5\text{ V}, V_D = 3\text{ V}, I_S = 1\text{ mA}$	Room			8.0	
Switch Off Leakage Current ^a	$I_{\text{S(off)}}$	$V_+ = 5.5\text{ V}, V_{\overline{EN}} = 2\text{ V}$ $V_S = 1\text{ V}$ or $4.5\text{ V}, V_D = 4.5\text{ V}$ or 1 V	Room Full	-1 -20		1 20	nA
	$I_{\text{D(off)}}$		Room Full	-1 -20		1 20	
Channel On Leakage Current ^a	$I_{\text{D(on)}}$	$V_+ = 5.5\text{ V}, V_{\overline{EN}} = 0\text{ V}$ $V_D = V_S = 1\text{ V}$ or 4.5 V	Room Full	-2 -10		2 10	
Digital Control							
Logic High Input Voltage	V_{INH}		Full	2.0			V
Logic Low Input Voltage	V_{INL}		Full			0.8	
Input Current ^a	I_{IN}	$V_{\text{AX}} = V_{\overline{EN}} = 2.0\text{ V}$ or 0.8 V	Full	-1		1	μA
Dynamic Characteristics							
Transition Time	t_{TRANS}	$V_+ = 4.5\text{ V}, V_- = 0\text{ V}, V_{\text{NO/NC}} = 3\text{ V} / 0\text{ V},$ $0\text{ V} / 3\text{ V}, R_L = 300\ \Omega, C_L = 35\text{ pF}$	Room		40		ns
Break-Before-Make Time	t_{BBM}	$V_+ = 4.5\text{ V}, V_{\text{X,Y,Z}} = 3\text{ V}, V_S = 0\text{ V},$ $R_L = 300\ \Omega, C_L = 35\text{ pF}$	Room		15		
Enable Turn-On Time	$t_{\text{ON}(\overline{\text{EN}})}$		Room		40		
Enable Turn-Off Time	$t_{\text{OFF}(\overline{\text{EN}})}$		Room		20		
Charge Injection ^e	Q	$C_L = 1\text{ nF}, V_{\text{GEN}} = 0\text{ V}, R_{\text{GEN}} = 0\ \Omega$	Room		20		pC
Off-Isolation ^{e,h}	OIRR	$f = 1\text{ MHz}, R_L = 50\ \Omega$	Room		-79		dB
Crosstalk ^e	X_{TALK}		Room		-83		
Source Off Capacitance ^e	$C_{\text{S(off)}}$	$f = 1\text{ MHz}, V_S = 0\text{ V}, V_{\overline{EN}} = 0\text{ V}$	Room		4		pF
Drain Off Capacitance ^e	$C_{\text{D(off)}}$	$f = 1\text{ MHz}, V_D = 0\text{ V}, V_{\overline{EN}} = 2.0\text{ V}$	Room		8		
Drain On Capacitance ^e	$C_{\text{D(on)}}$	$f = 1\text{ MHz}, V_D = 0\text{ V}, V_{\overline{EN}} = 0\text{ V}$	Room		15		
Power Supply							
Power Supply Current	I_+	$V_{\overline{EN}} = V_A = 0\text{ V}$ or V_+	Room			1.0	μA

DG9051/9052/9053

Vishay Siliconix

New Product



SPECIFICATIONS (SINGLE SUPPLY 3 V)							
Parameter	Symbol	Test Condition Otherwise Unless Specified $V_+ = 3\text{ V}$, $\pm 10\%$, $V_- = 0\text{ V}$ $V_{\overline{\text{EN}}} = 0.4\text{ V}$ or 2.0 V	Temp ^b	Limits –40 to 85°C			Unit
				Min ^c	Typ ^d	Max ^c	
Analog Switch							
Analog Signal Range ^e	V_{ANALOG}		Full	0		3	V
On-Resistance	r_{ON}	$V_+ = 2.7\text{ V}$, $V_D = 1.5\text{ V}$, $I_S = 0.1\text{ mA}$	Room		130		Ω
r_{ON} Match Between Channels ^g	Δr_{ON}	$V_+ = 2.7\text{ V}$, $V_D = 1.5\text{ V}$, $I_S = 0.1\text{ mA}$	Room			12	
Switch Off Leakage Current ^a	$I_{\text{S(off)}}$	$V_+ = 3.3\text{ V}$, $V_{\overline{\text{EN}}} = 2.0\text{ V}$ $V_S = 3$ or 0.3 V , $V_D = 0.3$ or 3 V	Room	–1		1	nA
	$I_{\text{D(off)}}$		Full	–20		20	
Channel On Leakage Current ^a	$I_{\text{D(on)}}$	$V_+ = 3.3\text{ V}$, $V_{\overline{\text{EN}}} = 0\text{ V}$ $V_S = 3$ or 0.3 V , $V_D = 0.3$ or 3 V	Room	–2		2	
			Full	–10		10	
Digital Control							
Logic High Input Voltage	V_{INH}		Full	2.0			V
Logic Low Input Voltage	V_{INL}		Full			0.4	
Input Current ^a	I_{IN}	$V_{\text{AX}} = V_{\overline{\text{EN}}} = 2.0\text{ V}$ or 0.4 V	Full	–1		1	μA
Dynamic Characteristics							
Transition Time	t_{TRANS}	$V_+ = 2.7\text{ V}$, $V_{\text{NO/NC}} = 1.5\text{ V/0 V}$, 0 V/1.5 V $R_L = 300\ \Omega$, $C_L = 35\text{ pF}$	Room		80		ns
Break-Before-Make Time	t_{BBM}	$V_+ = 2.7\text{ V}$, $V_{\text{X,Y,Z}} = 1.5\text{ V}$, $V_S = 0\text{ V}$, $R_L = 300\ \Omega$, $C_L = 35\text{ pF}$	Room	5	25		
Enable Turn-On Time	$t_{\text{ON}(\overline{\text{EN}})}$		Full		90		
Enable Turn-Off Time	$t_{\text{OFF}(\overline{\text{EN}})}$		Room		30		
Charge Injection ^e	Q	$C_L = 1\text{ nF}$, $V_{\text{GEN}} = 0\text{ V}$, $R_{\text{GEN}} = 0\ \Omega$	Room		9		pC
Off-Isolation ^{e,h}	OIRR	$f = 1\text{ MHz}$, $R_L = 50\ \Omega$	Room		–78		dB
Crosstalk ^e	X_{TALK}		Room		–83		
Source Off Capacitance ^e	$C_{\text{S(off)}}$	$f = 1\text{ MHz}$, $V_S = 0\text{ V}$, $V_{\overline{\text{EN}}} = 1.8\text{ V}$	Room		5		pF
Drain Off Capacitance ^e	$C_{\text{D(off)}}$	$f = 1\text{ MHz}$, $V_D = 0\text{ V}$, $V_{\overline{\text{EN}}} = 1.8\text{ V}$	Room		10		
Drain On Capacitance ^e	$C_{\text{D(on)}}$	$f = 1\text{ MHz}$, $V_D = 0\text{ V}$, $V_{\overline{\text{EN}}} = 0\text{ V}$	Room		15		
Power Supply							
Power Supply Current	I_+	$V_{\overline{\text{EN}}} = V_A = 0\text{ V}$ or V_+	Room			1.0	μA

Notes

- Leakage parameters are guaranteed by worst case test condition and not subject to production test.
- Room = 25°C, Full = as determined by the operating temperature suffix.
- The algebraic convention whereby the most negative value is a minimum and the most positive a maximum, is used in this data sheet.
- Typical values are for DESIGN AID ONLY, not guaranteed nor subject to production testing.
- Guaranteed by design, not subject to production test.
- V_{IN} = input voltage to perform proper function.
- $\Delta r_{\text{DON}} = r_{\text{DON Max}} - r_{\text{DON Min}}$.
- Worst case isolation occurs on Channel 4 due to proximity to the drain pin.
- r_{DON} flatness is measured as the difference between the minimum and maximum measured values across a defined Analog signal.

Stresses beyond those listed under "Absolute Maximum Ratings" may cause permanent damage to the device. These are stress ratings only, and functional operation of the device at these or any other conditions beyond those indicated in the operational sections of the specifications is not implied. Exposure to absolute maximum rating conditions for extended periods may affect device reliability.



TYPICAL CHARACTERISTICS $T_A = 25\text{ }^\circ\text{C}$, unless otherwise noted

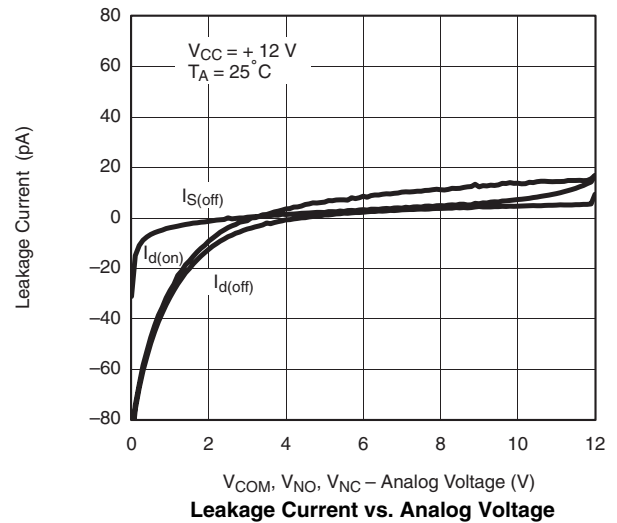
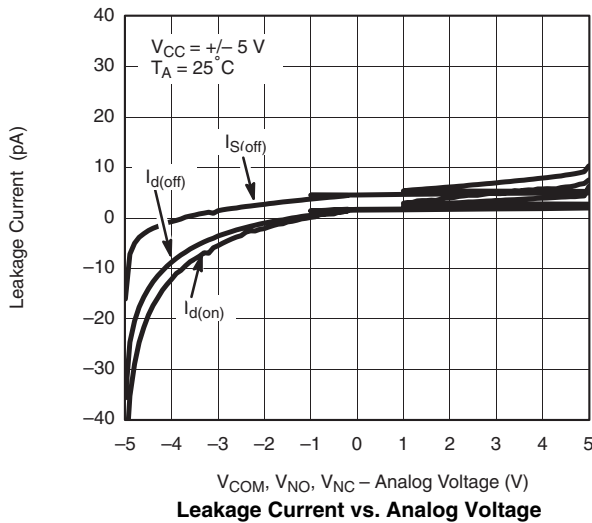
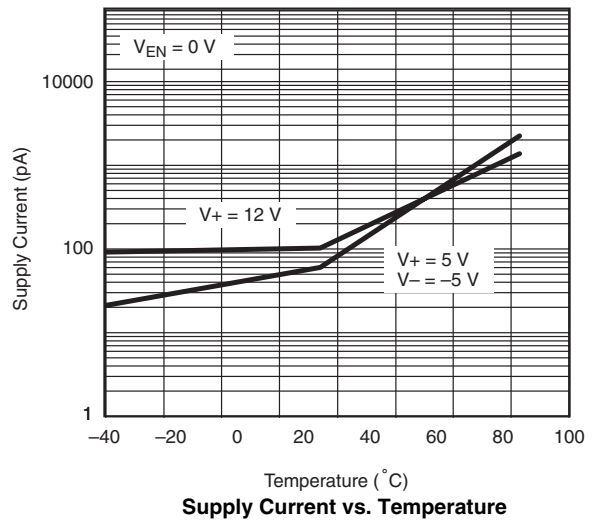
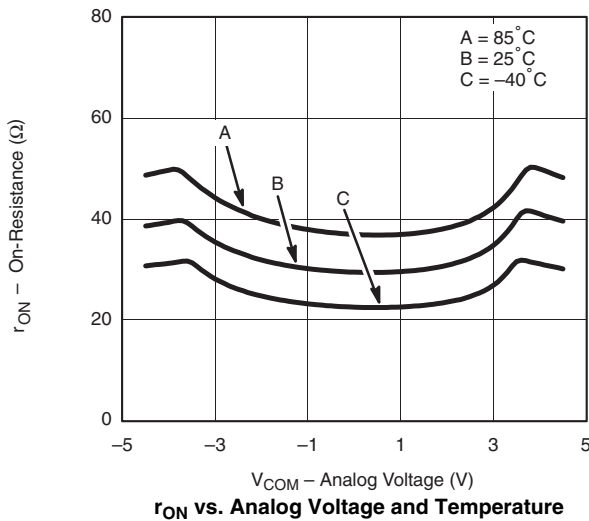
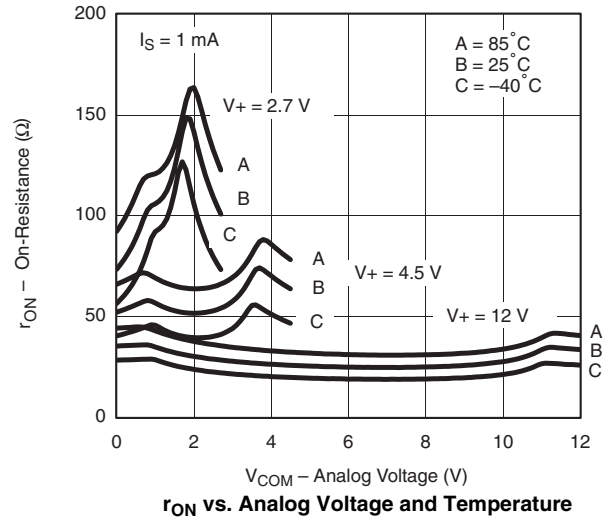
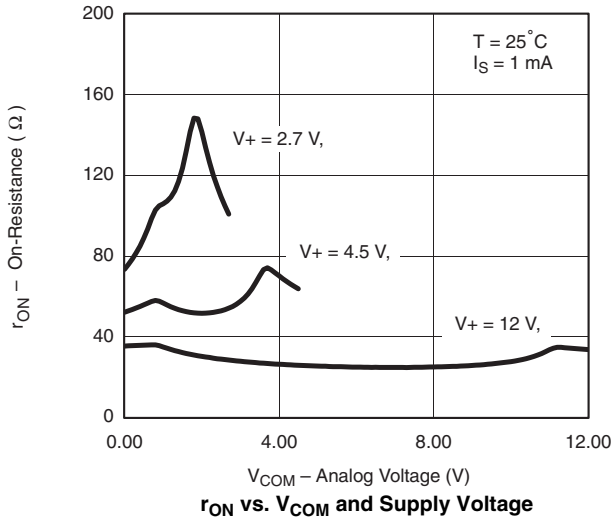

DG9051/9052/9053



Vishay Siliconix

New Product

TYPICAL CHARACTERISTICS $T_A = 25\text{ }^\circ\text{C}$, unless otherwise noted

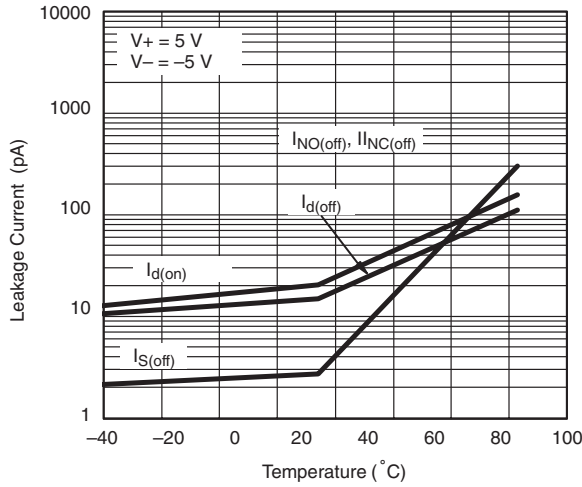

Leakage Current vs. Temperature

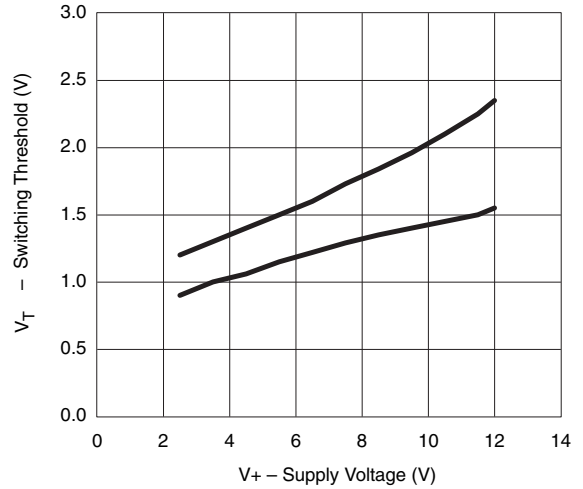

Switching Threshold vs. Supply Voltage

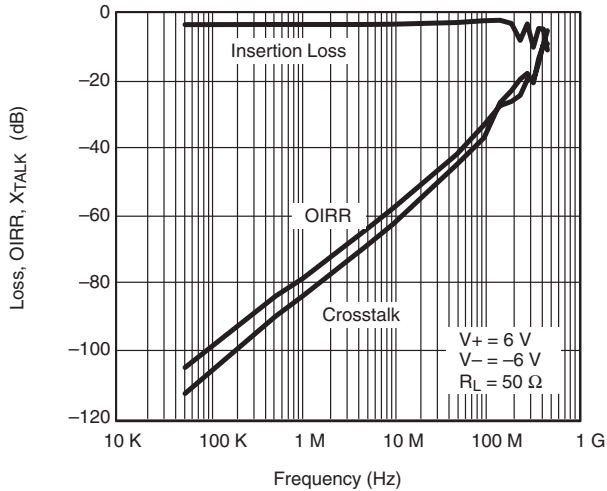

Insertion Loss, Off-Isolation Crosstalk vs. Frequency

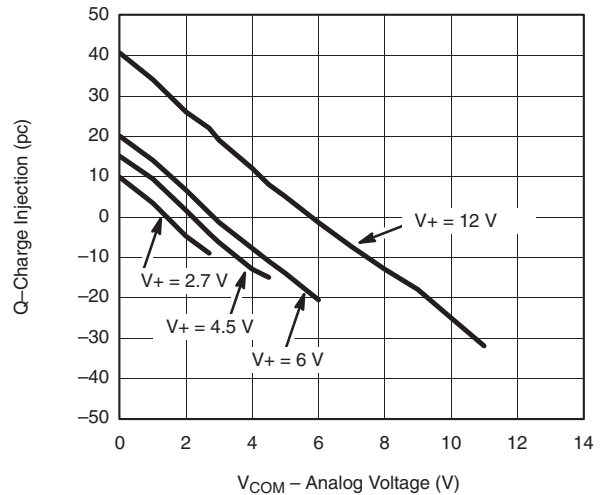

Charge Injection vs. Analog Voltage

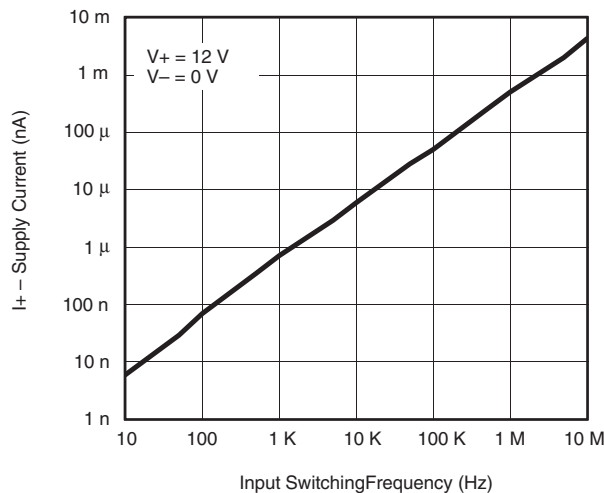

Supply Current vs. Input Switching Frequency



TEST CIRCUITS

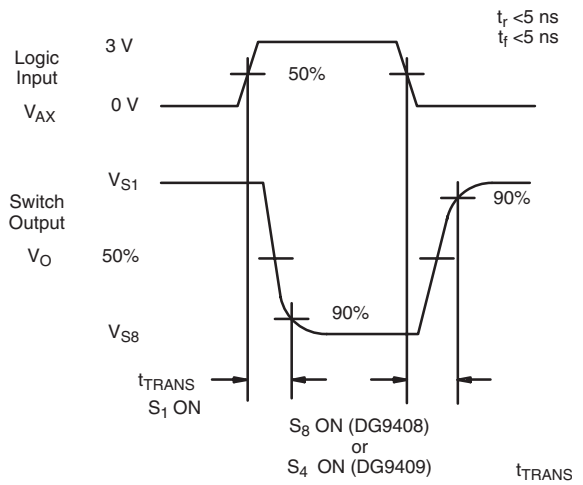
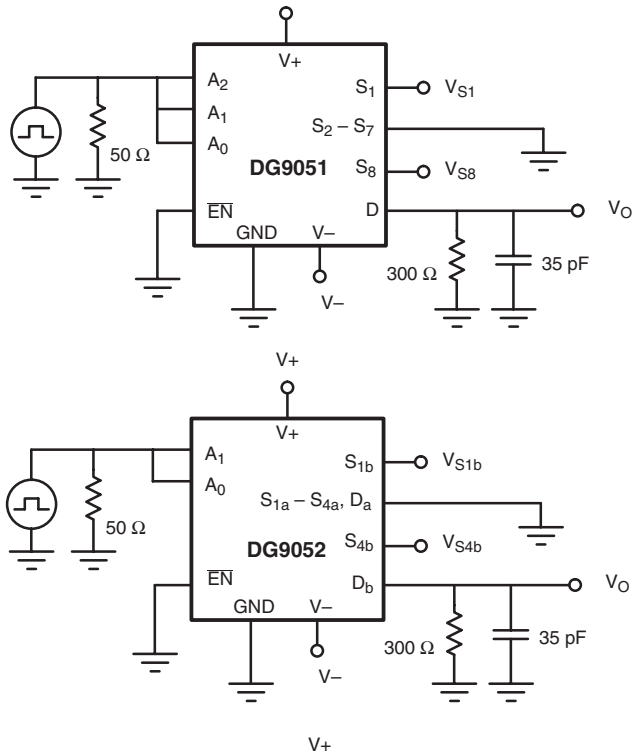

Return to Specifications:
 Single Supply 12 V
 Dual Supply V+ = 5 V, V- = -5 V
 Single Supply 5 V
 Single Supply 3 V

Figure 1. Transition Time

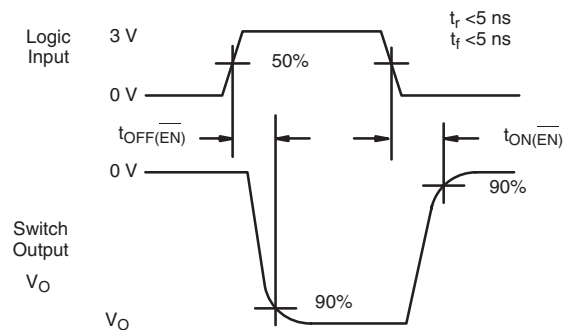
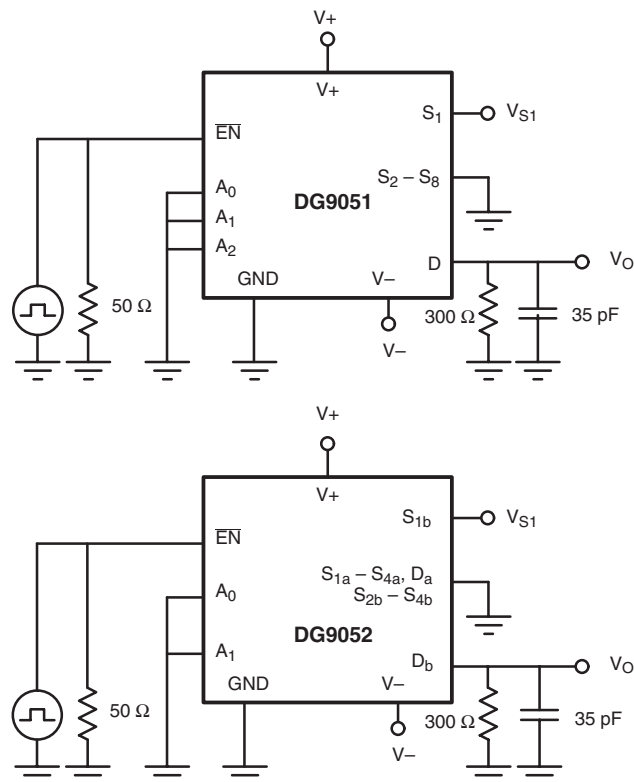

Return to Specifications:
 Single Supply 12 V
 Dual Supply V+ = 5 V, V- = -5 V
 Single Supply 5 V
 Single Supply 3 V

Figure 2. Enable Switching Time

DG9051/9052/9053

Vishay Siliconix

New Product



TEST CIRCUITS

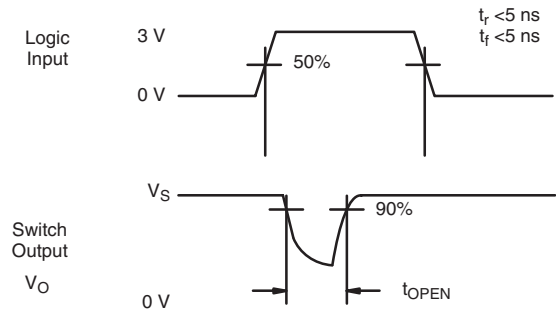
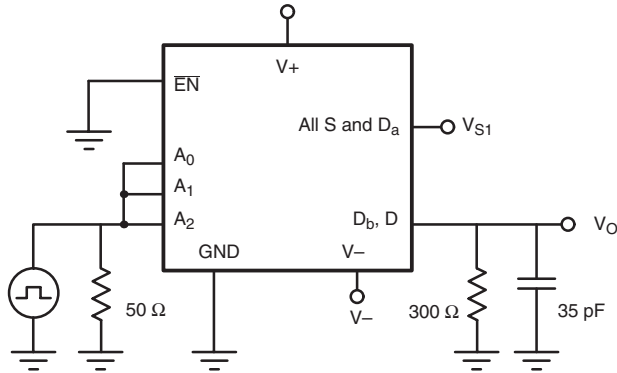

Return to Specifications:
 Single Supply 12 V
 Dual Supply V+ = 5 V, V- = -5 V
 Single Supply 5 V
 Single Supply 3 V

Figure 3. Break-Before-Make Interval

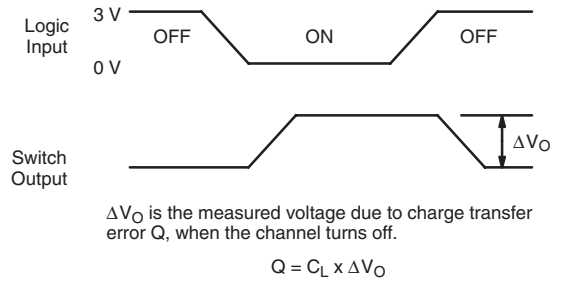
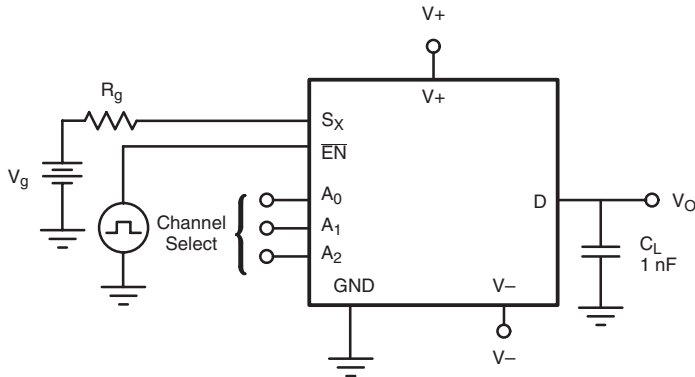

Figure 4. Charge Injection

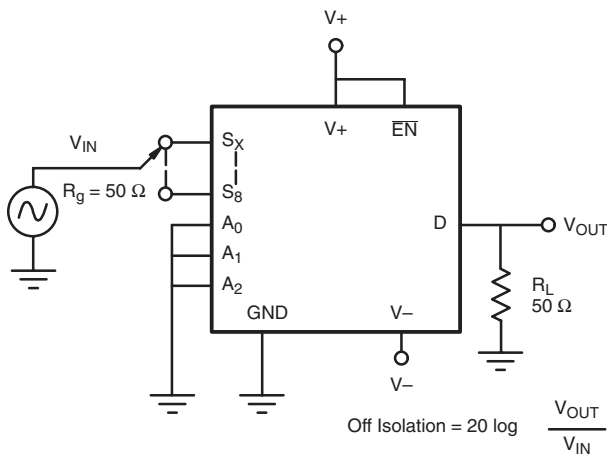

Figure 5. Off Isolation

$$\text{Off Isolation} = 20 \log \frac{V_{OUT}}{V_{IN}}$$

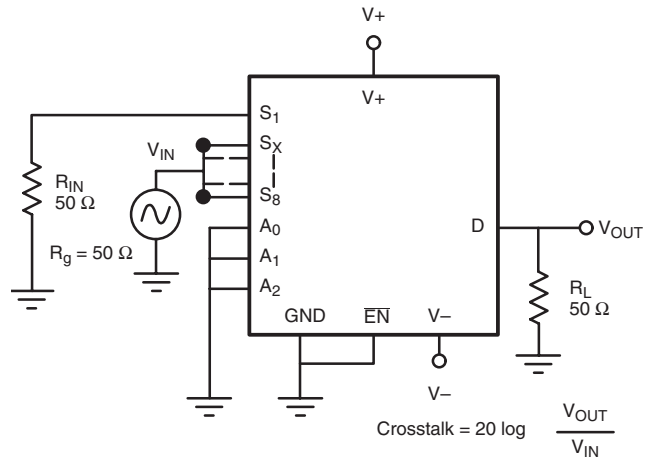

Figure 6. Crosstalk

$$\text{Crosstalk} = 20 \log \frac{V_{OUT}}{V_{IN}}$$



TEST CIRCUITS

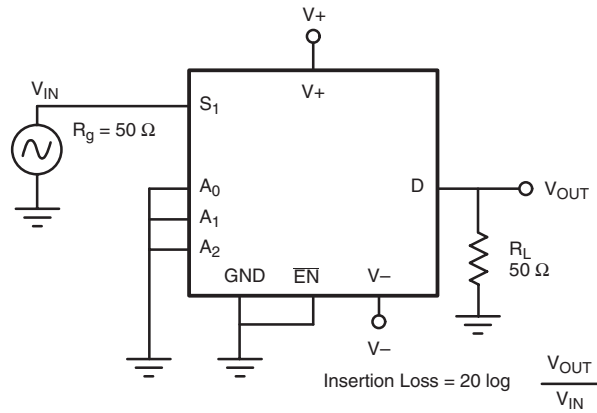

Figure 7. Insertion Loss

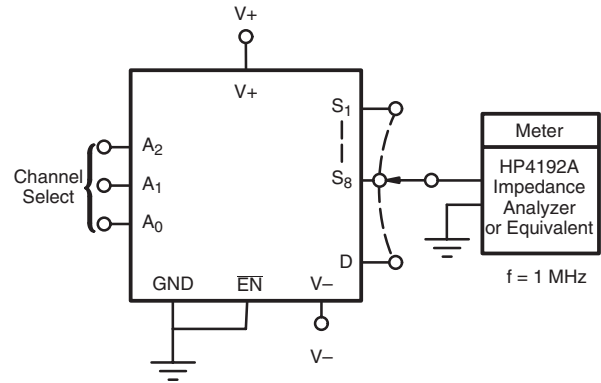

Figure 8. Source Drain Capacitance

Vishay Siliconix maintains worldwide manufacturing capability. Products may be manufactured at one of several qualified locations. Reliability data for Silicon Technology and Package Reliability represent a composite of all qualified locations. For related documents such as package/tape drawings, part marking, and reliability data, see <http://www.vishay.com/ppg?73410>.



Notice

Specifications of the products displayed herein are subject to change without notice. Vishay Intertechnology, Inc., or anyone on its behalf, assumes no responsibility or liability for any errors or inaccuracies.

Information contained herein is intended to provide a product description only. No license, express or implied, by estoppel or otherwise, to any intellectual property rights is granted by this document. Except as provided in Vishay's terms and conditions of sale for such products, Vishay assumes no liability whatsoever, and disclaims any express or implied warranty, relating to sale and/or use of Vishay products including liability or warranties relating to fitness for a particular purpose, merchantability, or infringement of any patent, copyright, or other intellectual property right.

The products shown herein are not designed for use in medical, life-saving, or life-sustaining applications. Customers using or selling these products for use in such applications do so at their own risk and agree to fully indemnify Vishay for any damages resulting from such improper use or sale.