



Level Translators/Buffers

DH0034/DH0034C

DH0034/DH0034C high speed dual level translator

general description

The DH0034/DH0034C is a high speed level translator suitable for interfacing to MOS or junction FET analog switches. It may also be used as a universal logic level shifter capable of accepting TTL/DTL input levels and shifting to CML, MOS, or SLT levels.

features

- Fast switching, t_{pd0} : typically 15 ns; t_{pd1} : typically 35 ns
- Large output voltage range: 25V
- Input is TTL/DTL compatible
- Low output leakage: typically 0.1 μ A
- High output currents: up to ± 100 mA

schematic and connection diagrams

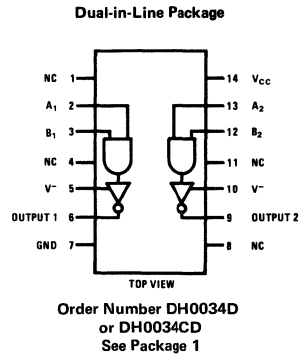
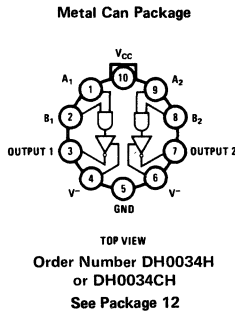
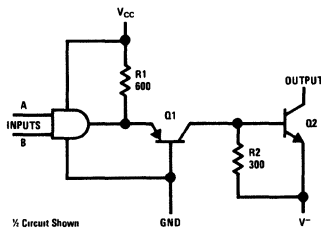

typical applications

5 MHz Analog Switch

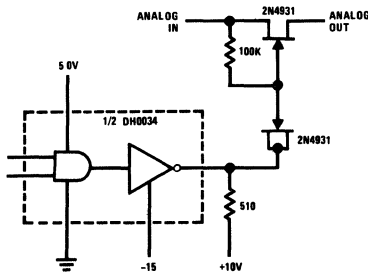

TTL to IBM (SLT) Logic Levels

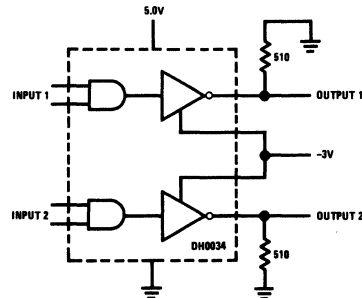

2

absolute maximum ratings

V _{CC} Supply Voltage	7.0V
Negative Supply Voltage	-30V
Positive Supply Voltage	+25V
Differential Supply Voltage	25V
Maximum Output Current	100 mA
Input Voltage	+5.5V
Operating Temperature Range: DH0034	-55°C to +125°C
DH0034C	0°C to +85°C
Storage Temperature Range	-65°C to +150°C
Lead Temperature (Soldering, 10 sec)	300°C

electrical characteristics (See Notes 1 & 2)

PARAMETER	CONDITIONS	DH0034			DH0034C			UNITS
		MIN	TYP	MAX	MIN	TYP	MAX	
Logical "1" Input Voltage	V _{CC} = 4.5V V _{CC} = 4.75V	2.0			2.0			V
Logical "0" Input Voltage	V _{CC} = 5.5V V _{CC} = 4.75V			0.8			0.8	V
Logical "1" Input Current	V _{CC} = 5.5V, V _{IN} = 2.4V V _{CC} = 5.25V, V _{IN} = 2.4V		40				40	μA
Logical "1" Input Current	V _{CC} = 5.5V, V _{IN} = 5.5V V _{CC} = 5.25V, V _{IN} = 5.5V			1.0			1.0	mA
Logical "0" Input Current	V _{CC} = 5.5V, V _{IN} = 0.4V V _{CC} = 5.25V, V _{IN} = 0.4V			1.6			1.6	mA
Power Supply Current	(Note 3) V _{CC} = 5.5V, V _{IN} = 4.5V		30	38				mA
Logic "0" Power Supply Current	(Note 3) V _{CC} = 5.5V, V _{IN} = 0V		37	48				mA
Logic "1" Power Supply Current	(Note 3) V _{CC} = 5.25V, V _{IN} = 0V				37	48		mA
Logical "0" Output Voltage	V _{CC} = 4.5V, I _{OUT} = 100 mA V _{CC} = 4.5V, I _{OUT} = 50 mA		V ⁻ + .50 V ⁻ + .3	V ⁻ + .75 V ⁻ + .50		V ⁻ + .50 V ⁻ + .3	V ⁻ + .80 V ⁻ + .65	V V
Output Leakage Current	V _{CC} = 5.5V, V _{IN} = 0.8V V ⁺ - V ⁻ = 25V		0.1	5		0.1	5	μA
Transition Time to Logical "0"	V _{CC} = 5.0V, V ₃ = 0V, T _A = 25°C V ⁻ = -25V, R _L = 510Ω		15	25		15	35	ns
Transition Time to Logical "1"	V _{CC} = 5.0V, T _A = 25°C V ⁻ = -25V, R _L = 510Ω		35	60		35	65	ns

Note 1: These specifications apply over the temperature range -55°C to +125°C for the DH0034 and 0°C to +85°C for the DH0034C with a 510 ohm resistor connected between output and ground, and V⁻ connected to -25V, unless otherwise specified.

Note 2: All typical values are for T_A = 25°C.

Note 3: Current, measured is total drawn from V_{CC} supply.

theory of operation

When both inputs of the DH0034 are raised to logic "1", the input AND gate is turned "on" allowing Q1's emitter to become forward biased. Q1 provides a level shift and constant output current. The collector current is essentially the same as the emitter which is given by $\frac{V_{CC} - V_{BE}}{R_1}$

Approximately 7.0 mA flows out of Q1's collector.

About 2 mA of Q1's collector current is drawn off by pull down resistor, R2. The balance, 5 mA, is available as base drive to Q2 and to charge its associated Miller capacitance. The output is pulled to within a V_{SAT} of V^- . When either (or both) input to the DH0034 is lowered to logic "0," the AND gate output drops to 0.2V turning Q1 off. Deprived of base drive Q2 rapidly turns off causing the output to rise to the V_3 supply voltage. Since Q2's emitter operates between 0.6V and 0.2V, the speed of the DH0034 is greatly enhanced.

applications information

1. Paralleling the Outputs

The outputs of the DH0034 may be paralleled to increase output drive capability or to accomplish the "wire OR". In order to prevent current hogging by one output transistor or the other, resistors of 2 ohms/100 mA value should be inserted between the emitters of the output transistors and the minus supply.

2. Recommended Output Voltage Swing

The graph shows boundary conditions which govern proper operation of the DH0034. The range of operation for the negative supply is shown on the X axis and must be between -3V and -25V. The allowable range for the positive supply is governed by the value chosen for V^- . V^+ may be selected by drawing a vertical line through the selected value for V^- and terminated by the

boundaries of the operating region. For example, a value of V^- equal to -6V would dictate values of

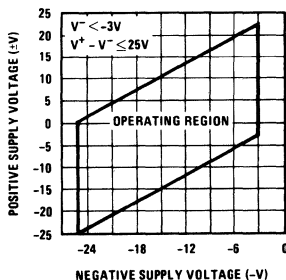

V^+ between -5V and +19V. In general, it is desirable to maintain at least 5V difference between the supplies.