

Name: **DHT11 Humidity and Temperature Digital Sensor**

Code: **MR003-005.1**

This board is a breakout board for the DHT11 sensor and gives a digital output that is proportional to temperature and humidity measured by the sensor. Technology used to produce the DHT11 sensor grants high reliability, excellent long-term stability and very fast response time.

Each DHT11 element is accurately calibrated in the laboratory. Calibration coefficient is stored in the internal OTP memory and this value is used by the sensor's internal signal detecting process.

The single-wire serial interface makes the integration of this sensor in digital system quick and easy.

Sensor physical interfacing is realized through a 0.1" pitch 3-pin connector: +5V, GND and DATA. First two pins are power supply and ground and they are used to power the sensor, the third one is the sensor digital output signal.

Its small physical size (1.05"x0.7") and its very light weight (just 0.1oz) make this board an ideal choice to implementing small robots and ambient monitoring systems.

## **CONNECTIONS**

DATA	Serial data output
GND	Ground
+5V	Power supply (+5V)

**Tab.1 – Connections**

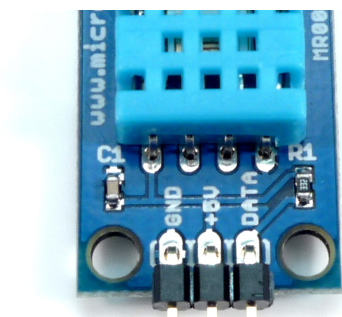

Fig. 1 - Signals

## CHARACTERISTICS

Supply voltage	+5V
Supply current (running)	0.5mA typ. (2.5mA max.)
Supply current (stand-by)	100uA typ. (150uA max.)
Temperature range	0 / +50°C ±2°C
Humidity range	20-90%RH ±5%RH
Interface	Digital
Dimensions	1.05" x 0.7" (connectors excluded)
Weight	0.1 oz (2.7g)

Tab.2 - Characteristics

## SENSOR UTILIZATION

The single-wire bus needs a 5Kohm pull-up resistor and the connection with the system is realized as showed in Fig.2.

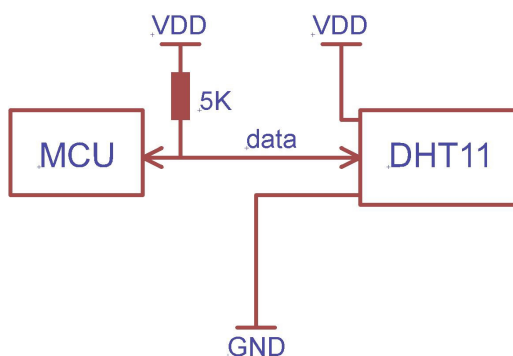

Fig. 2 - System

When power is supplied to the sensor, you haven't to send any instruction to the sensor in within one second in order to pass the start-up status.

After DHT11 is powered up, it goes in low power standby mode and it waits to recognize a Start Signal on the DATA line. Start Signal consists in a low voltage level on DATA line for a minimum of 18mS to ensure the DHT11 detects it, then followed by a pull-up voltage for about 40us.

Now the microcontroller has to wait the DHT11 transmission.

Once DHT11 detects the Start Signal, it will send out a low voltage level response signal, which lasts 80us. Then it sets the voltage level from low to high and keeps it for 80us.

Now data transmission will start. Every bit of data begins with the 50us low voltage level and then switch to high voltage level; high voltage level duration depends on the bit value that have to be transmitted: a 1 bit has an high voltage level duration of 27uS, a 0 bit has an high voltage level duration of 70uS.

When the last bit data is transmitted, DHT11 pulls down the voltage level and keeps it for 50us, then it leaves the line pulled-up and goes back in the stand-by mode.

To make another sensor read it needs to repeat this cycle, sending again the Start Signal after a minimum of one second from the previous cycle.

A complete data transmission is 40bit, so a communication process is about 4mS. DHT11 sensor sends higher data bit first (MSB) in the following format:

Data = 8bit integral RH data + 8bit decimal RH data + 8bit integral T data + 8bit decimal T data + 8bit check-sum.

If the data transmission is right, the check-sum will be equal to the last 8bit of the sum of the four byte transmitted.

