



±800 V DIN RAIL-MOUNTABLE VOLTAGE SENSORS

GENERAL DESCRIPTION

The ModuLink ±800V isolated voltage sensors are easy-to-use devices, tailored for power electronics applications. When employed with imperix's BoomBox control platform, the sensors provide plug&play connectivity and can be directly powered by the control platform.

The devices produce a balanced full-differential output signal, proportional to the sensed voltage. For best EMC performance, the output signal is typically meant to be carried by a shielded twisted pair embedded in RJ45-type cables.

Modulink sensors can be easily clipped on 35mm DIN rails and are compatible with up to 6 mm² wires. They guarantee the galvanic isolation of the sensing circuit up to 1kV_{RMS}.

KEY FEATURES AND SPECIFICATIONS

- ±800V measuring range
- Minimum 60kHz measurement bandwidth
- Balanced full-differential signal output
- Typical sensitivity of 2.46 mV/V
- 1.2kV_{PK} galvanic isolation (permanent)
- ±0.15% typical precision
- Compatible with standard ±15V power supplies
- Mountable on 35 mm DIN rails

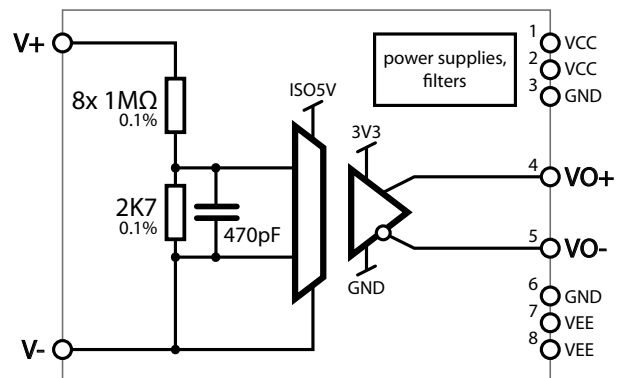

BOOMBOX CONFIGURATION

The recommended configuration for the BoomBox is shown in Table 1:

Sensitivity	Filter	Gain	Input
2.46 mV/V	Filter=NONE	G=4	High-impedance

Table 1. Suggested configuration of the BoomBox

Imperix recommends to consider calibrating each sensor for improved accuracy. When difficult, at least the offset shall be compensated for.

MECHANICAL DIMENSIONS

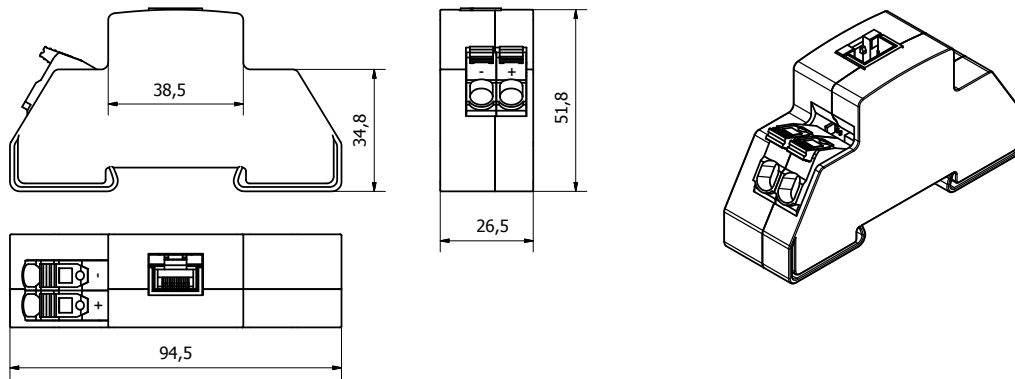

ABSOLUTE MAXIMUM RATINGS

Parameter	Symbol	Test conditions	Min.	Typ.	Max.	Unit
Maximum tolerable differential input voltage	$V_{in,max,abs}$		-	1.6	-	kV
Maximum working isolation voltage	V_{IORM}		-	1.2	-	kV _{PEAK}
Highest allowable short-term isolation voltage (60s)	V_{IOTM}		-	4.0	-	kV _{PEAK}
Power supply voltages	$\pm VCC$		± 12.0	± 15.0	± 16.0	V

SENSOR PARAMETERS

Parameter	Symbol	Test conditions	Min.	Typ.	Max.	Unit
Input voltage range – optimized accuracy range	$V_{in,nom}$		-	± 810	-	V
Input voltage range – full scale	$V_{in,max}$		-	± 1.0	-	kV
Nominal sensitivity	G		-	2.46	-	mV/V
Uncalibrated sensitivity error ⁶	G_{ERR}	$T_A = 25^\circ C$	-	± 0.15	± 1.4	%
Sensitivity error over temperature	$G_{ERR,t}$	$T_A = 25^\circ C$ to $85^\circ C$	-	± 0.35	-	%
Input-referred offset	V_O	$T_A = 25^\circ C$	-	± 0.7	± 4.9	V
Input-referred offset over temperature	$V_{O,t}$	$T_A = 25^\circ C$ to $85^\circ C$	-	± 0.4	± 2.0	V
Measurement bandwidth	f_{3dB}		60	100	-	kHz
Settling time	t_d	10%, -740V to +740V input step	-	5.3	9.9	μs
Input impedance	R_{IN}		-	8.0	-	M Ω
Input-referred noise	V_n		-	1.4	-	V
Output voltage range	$V_{o,max}$		-	± 2.0	± 2.56	V
Output current (short circuit)	I_{OUT}		-	20	-	mA
Power consumption	P_{DD}	On $\pm 15V$ power supplies	-	-	120	mW

⁶ Valid only for sensors sold after January 2017.

CONNECTOR PINOUT

Pin	Color	Description	Pin	Color	Description
1	orange stripe	+15 V	5	blue stripe	Signal negative output
2	orange solid		6	green solid	0 V
3	green stripe	0 V	7	brown stripe	-15 V
4	blue solid	Signal positive output / current output	8	brown solid	

CONTACT

imperix SA

Rue de l'Industrie 17
1950 Sion, Switzerland
phone: +41 (0)27 552 06 60
fax: +41 (0)27 552 06 69
www.imperix.ch, sales@imperix.ch

ABOUT US

Imperix SA (Ltd.) is a company established in Sion, Switzerland. Its name is derived from the Latin verb imperare, which stands for controlling and refers to the company's core business: the control of power electronic systems. Imperix SA commercializes hardware and software solutions dedicated to the fast and secure implementation of pilot systems and plants in the field of power conversion, energy storage and smart grids.

NOTE

While every effort has been made to ensure the accuracy of this publication, no responsibility can be accepted for errors or omissions. Data may change, as well as legislation, and the reader is strongly advised to obtain copies of the most recently issued regulations, standards, and guidelines. This publication does not form the basis of a contract. Copyright 2016. All rights reserved.