

DIO8215

Adaptive 100/120Hz Current Ripple Remover

Max LED Current $\leq 500\text{mA}$

Features

- Wide input voltage range
- Internal 150V power MOSFET
- Built-in zener diode for input voltage clamping
- VG output voltage high to 10V
- Programmable amplitude of LED current ripple
- Multiple protection features:
 - ✧ Reliable LED voltage limit
 - ✧ Reliable LED current limit
 - ✧ Reliable Short LED Protection (SLP)
 - ✧ Hot-plug protection
 - ✧ Over Temperature Protection (OTP)
- EP-SOIC8 Package

Descriptions

DIO8215 is used to drive a LED string, and remove the 100/120Hz current ripple on AC/DC power by a capacitor between VC and GND.

The adaptive technology of DIO8215 ensures minimum power dissipation on DIO8215 while removing LED current ripple.

DIO8215 clamps the input voltage on VIN pin by 37V. DIO8215 allows to regulate LED current limit, which protects DIO8215 from being damaged when LED short or hot-plug.

DIO8215 allows to regulate the cathode voltage limit of LED string, which could help limit the power dissipation on chip.

DIO8215 provides over thermal protection. When the OTP is triggered, the function of current ripple removing is shielded until the temperature drop to 130°C.

Applications

- Flickerless LED lighting

Block Diagram

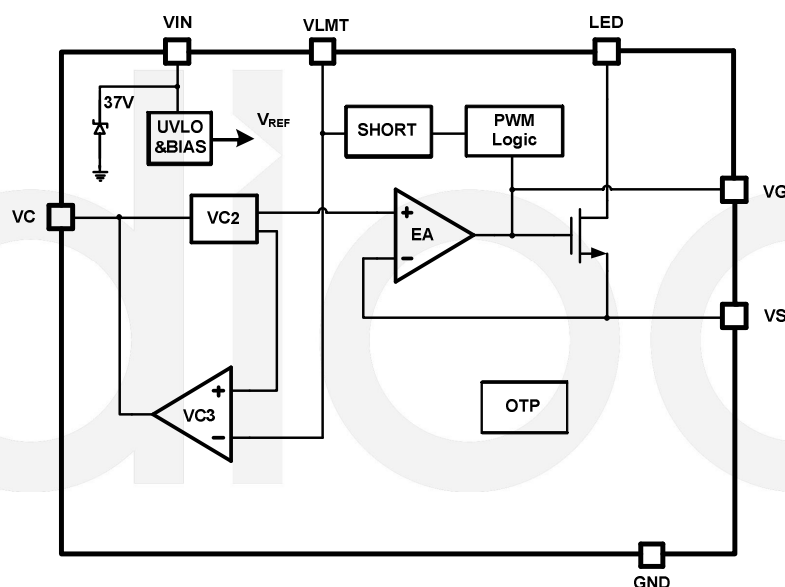

Ordering Information

Order Part Number	Top Marking		T _A	Package	
DIO8215XS8	DIO8215	Green	-40 to +150°C	EP-SOIC8	Tape & Reel, 2500

Pin Assignments

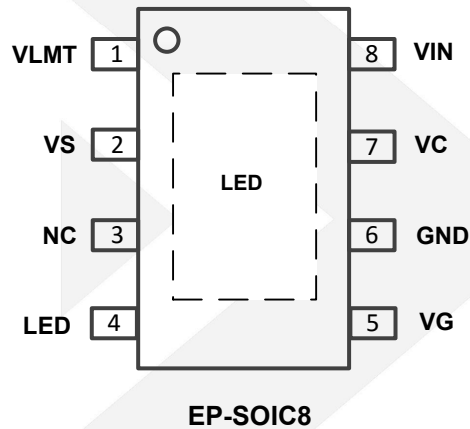

Figure 1 Pin Assignment (Top View)

Pin Definitions

Pin Name	Description
VIN	Power Supply voltage input
LED	Connect to the Cathode of LED string
GND	Ground pin
VLMT	Adjustable LED Short Protection Threshold and Cathode of LED string voltage limit
VC	Adjustable LED Current Ripple. By connecting a capacitor between VC to GND to regulate the current ripple.
VG	HV MOSFET gate pin
VS	HV MOSFET source pin. Connect the sense resistor across the source of HV MOSFET and the GND pin.
NC	Not Connect
LED (exposed PAD)	Connect to the Cathode of LED string



DIO8215

Adaptive 100/120Hz Current Ripple Remover, Max LED Current ≤500mA

Absolute Maximum Ratings

Stresses beyond those listed under “Absolute Maximum Rating” may cause permanent damage to the device. These are stress ratings only and functional operation of the device at these or any other condition beyond those indicated in the operational sections of the specifications is not implied. Exposure to absolute maximum rating conditions for extended periods may affect device reliability.

Parameter	Rating	Unit
VIN clamp voltage	37	V
VG	20	V
VS, VC, VLMT	-0.3 to 6	V
LED	150	V
Junction Temperature	150	°C
Lead Temperature	260	°C
Storage Temperature	-40 to +125	°C
Thermal Resistance / θ_{JA}	50	°C/W

Recommend Operating Conditions

The Recommended Operating Conditions table defines the conditions for actual device operation. Recommended Operating conditions are specified to ensure optimal performance to the datasheet specifications. DIOO does not Recommend exceeding them or designing to Absolute Maximum Ratings.

Parameter	Rating	Unit
Maximum Junction Temperature (T_J)	125	°C



DIO8215

Adaptive 100/120Hz Current Ripple Remover, Max LED Current ≤500mA

Electrical Characteristics

T_A = 25°C, V_{IN} = 12V, unless otherwise specified.

Symbol	Parameter	Test Conditions	Min	Typ	Max	Unit
V _{IN_CLP}	V _{IN} clamp voltage			37		V
I _{IN}	V _{IN} operation current	5V<V _{IN} <38V	0.21	0.24	0.3	mA
V _{IN_ON}	V _{IN} Power On Voltage Threshold			16		V
V _{IN_OFF}	V _{IN} Power Off Voltage Threshold			11		V
V _{VG}	Maximum VG output voltage			8		V
I _{VCST}	VC startup current	VC short to GND when startup	0.9	1.1	1.3	mA
V _{VLMT}	VLMT reference voltage		1.95	2	2.05	V
V _{LED_LIMIT}	LED Voltage Limit Threshold	LED voltage when voltage limit is triggered. R _{LIMIT} =100K.	3.5	4	4.5	V
V _{TH_SHORT}	Short protection threshold	Drain voltage of LED When short is triggered. R _{LIMIT} =100K.	5.5	6	7	V
T _{SP}	LED Short Protection Delay Time			70		μs
T _{SH}	LED Short Protection Hold Time			40		ms
V _{VS}	VS voltage limit		0.18	0.2	0.22	V
V _{BVDSS}	Break-down Voltage	I _{DS} =250μA, T _J =25°C	150			V

Specifications subject to change without notice.



Typical System Characteristics

$V_{IN}=176V\sim 264V_{AC}$, $V_{OUT}=72V$, $I_{OUT}=240mA$, $C_{OUT}=100\mu F/100V*2$, $T_A=25^{\circ}C$.

Efficiency Comparison with vs. without DIO8215

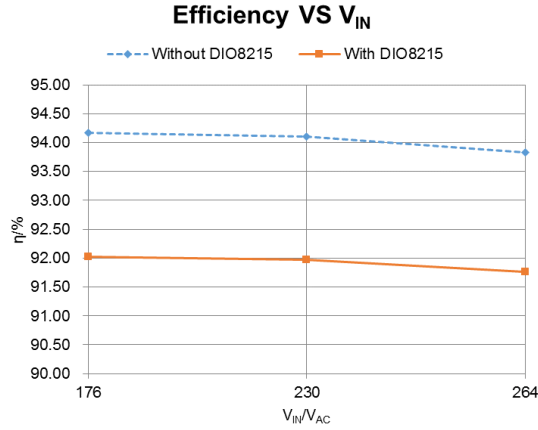

Current Ripple without DIO8215

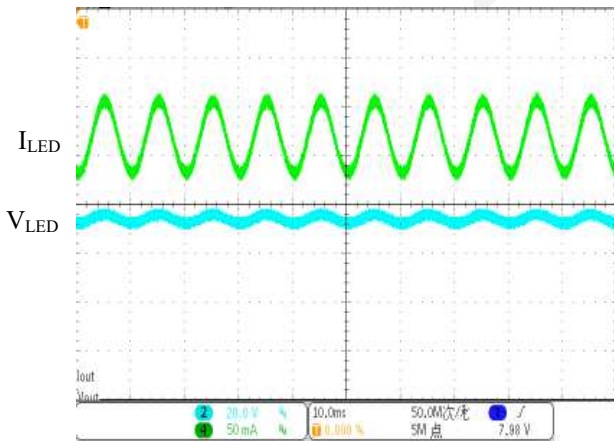

$I_{LED}: 50mA/div$

$V_{LED}: 20V/div$

Current Ripple with DIO8215

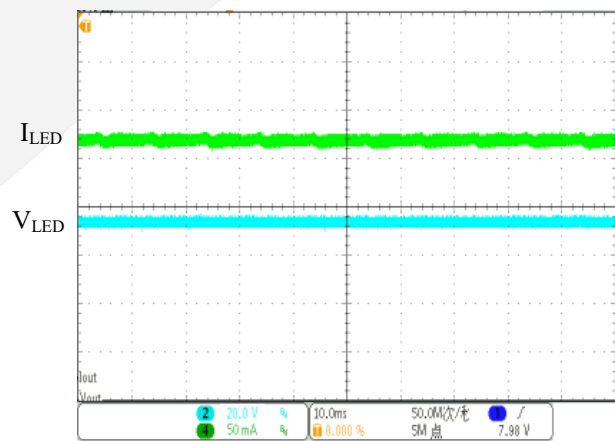

$I_{LED}: 50mA/div$

$V_{LED}: 20V/div$

Power ON

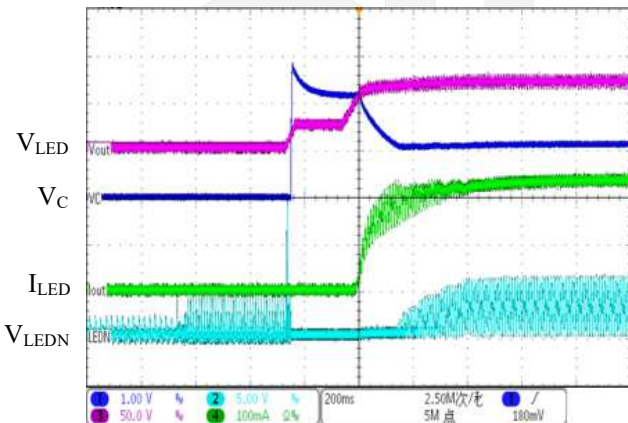

$V_C: 1V/div$

$V_{LEDN}: 5V/div$

$I_{LED}: 100mA/div$

$V_{LED}: 50V/div$

LED Hot plug test

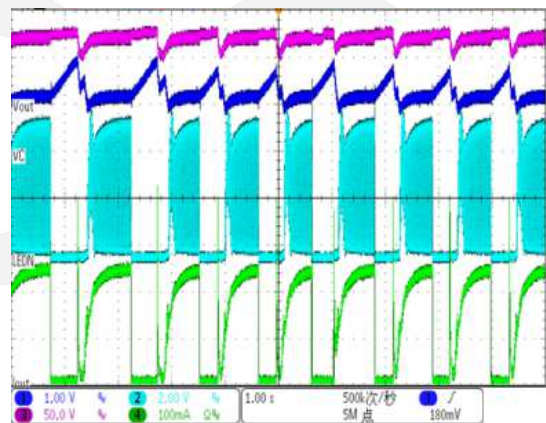

$V_C: 1V/div$

$V_{LEDN}: 2V/div$

$I_{LED}: 100mA/div$

$V_{LED}: 50V/div$

Line Input arcing test

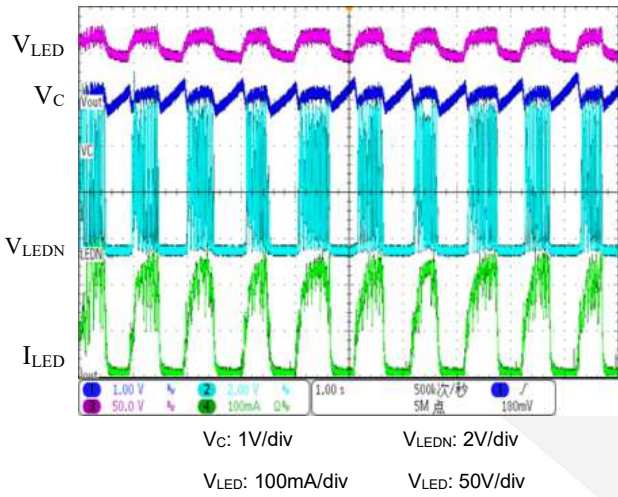

Dimming application test

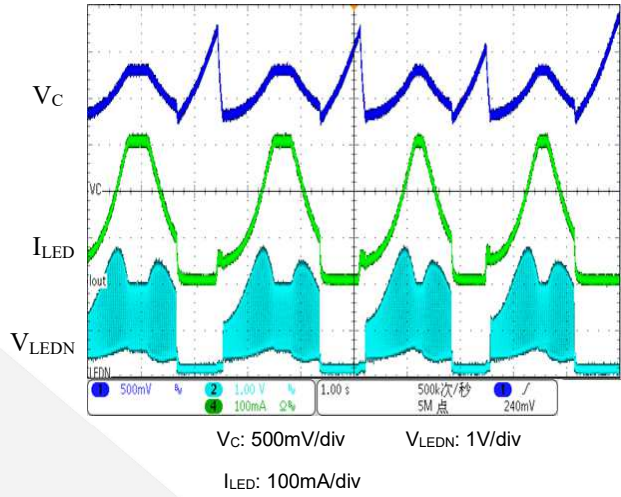

LED Open Protection test

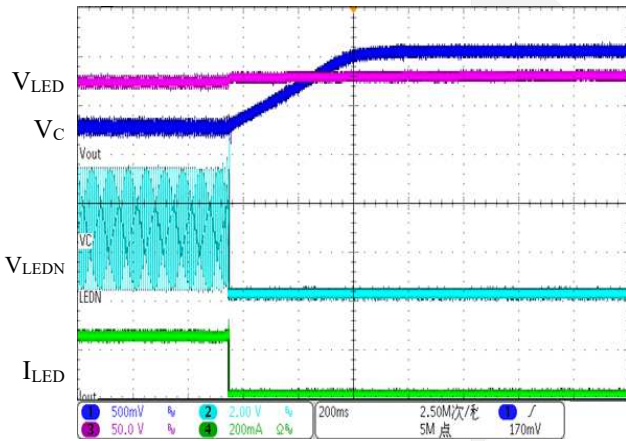

LED Short Protection test

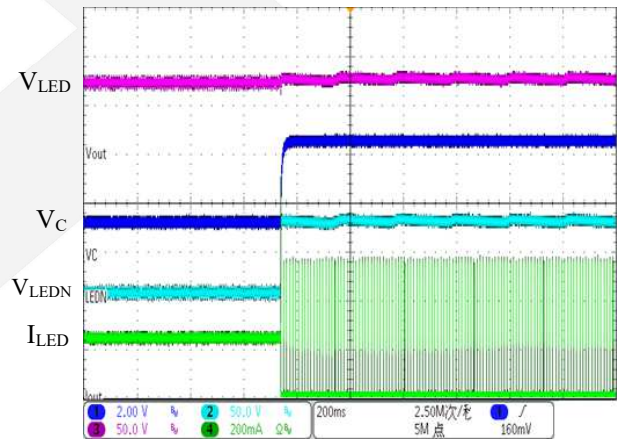

Functional Description

Theory of Operation:

The LED string and DIO8215 are both supplied by an AC/DC current source. The LED pin is connected to the cathode of LED string. A sensing resistor R_{SENSE} is connected between the VS and GND.

DIO8215 transfer the LED current ripple to voltage ripple, and ensures the constant voltage across LED string and the current flow through LED string. The scalable adaptive function of DIO8215 can regulate the cathode voltage of LED string to minimum to improve the efficiency of the system.

Current Ripple Removing:

The capacitor C_C between VC and GND is an integration capacitor. DIO8215 transform the voltage on C_C to a reference voltage. The current regulator regulates the voltage on R_{SENSE} equal to the reference voltage.

The relationship between the voltage on C_C and R_S is shown as following:

$$V_{RS} = I_{LED} * R_{SENSE} = V_{VC} / 10$$

C_C should be large enough in order to remove the current ripple of the LED string. However, too large capacitor may slow down the dynamic response.

Adaptive Regulation:

DIO8215 control the voltage on C_C by monitoring the operation state of integrated NMOSFET. The efficiency of system is relatively low when NMOSFET is working in the saturation region. DIO8215 detects it and charges C_C to raise the V_{VC} and I_{LED} , then the output voltage of power supply is reduced, and the voltage drop on NMOSFET decreases.

Conversely, when NMOSFET is working in the linear region, LED current regulation loop is open. DIO8215 detects it and discharges C_C to reduce the V_{VC} and I_{LED} , then the output voltage of power supply is raised, and the LED current regulation loop is close.

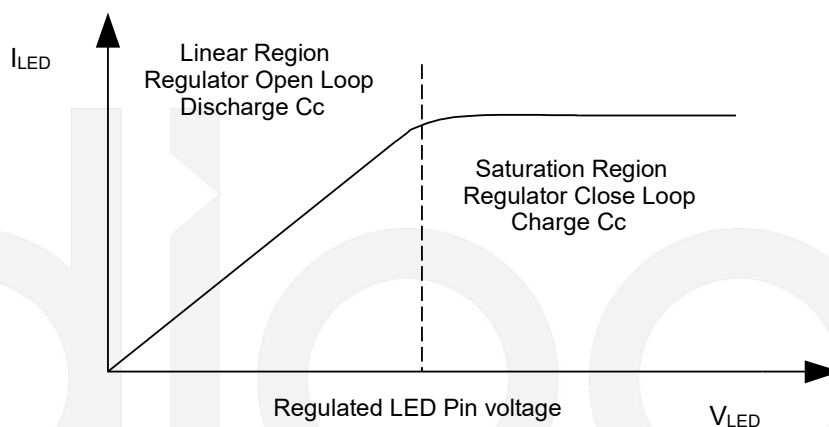

The Voltage of LED Limit:

The voltage ripple on LED pin maybe very large when the current ripple is removed, which would bring large power dissipation on chip. The resistor between LED pin and VLMT pin can setup the limit value of the voltage of LED pin.

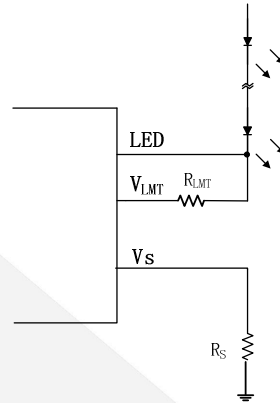

The limit threshold is calculated as below:

$$V_{LMT} = 2V + R_{LMT} * 20\mu A$$

LED Current Limit:

The voltage of VS pin is limited to 0.2V internally. So the current limitation is 0.2V/Rs. Current limit can protect the chip when LED is short connected or HOT-PLUG. The function of current limit is higher priority than LED voltage limit. It means that the voltage of LED pin is not limited when LED current exceed current limit threshold.

LED Short Protection:

DIO8215 detect short by R_{LMT}. When the drain voltage of LED pin exceeds the short protection threshold and the state holds for more than 70μs, DIO8215 considers the LED string is short connected and shuts down. The short state is reset after 40ms.

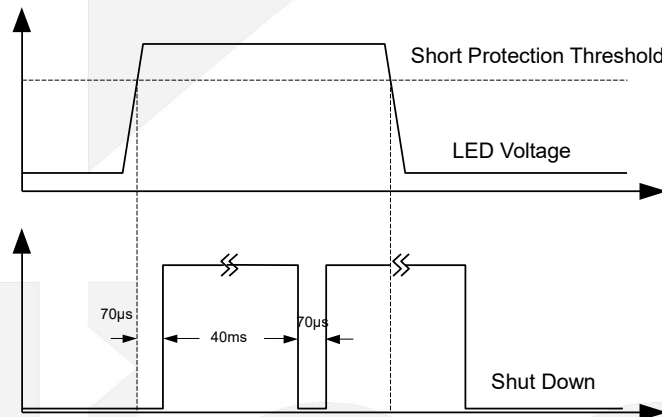

The short protection threshold is calculated as below:

$$V_{THSCP} = 2V + R_{LMT} * 40\mu A$$

Over Thermal Protection:

DIO8215 monitors operation temperature. When the temperature is higher than 135°C, the chip is shut down until the temperature decrease to 110°C.

PCB Design Guideline:

1. The bypass capacitor of VIN should be placed as close as possible to the VIN pin and GND pin of IC.
2. The area of LED current loop should be as small as possible.

Application note

DIO8215 design guide:

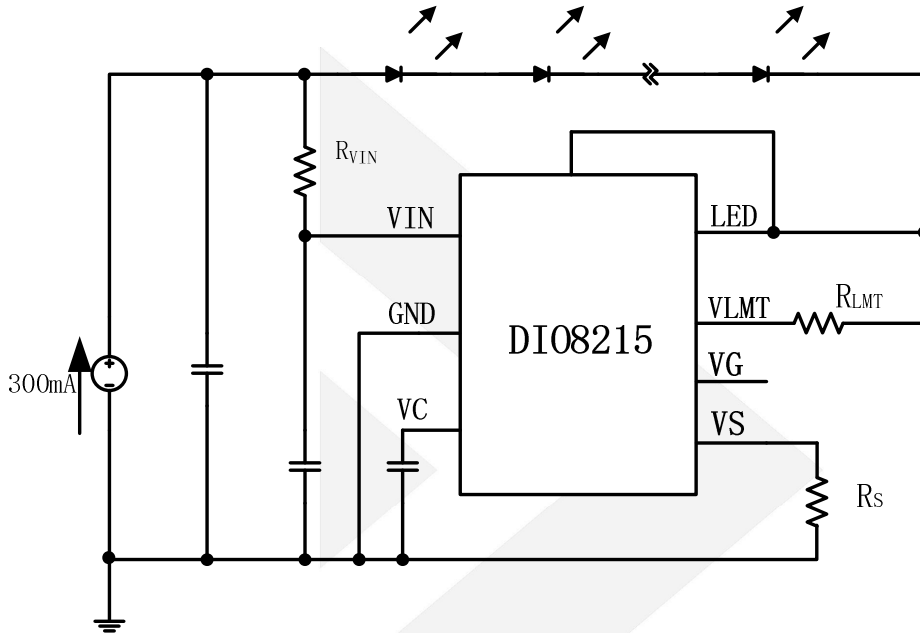

1. Because of the 37V zener integrated and the 16V VIN start threshold, the value of R_{VIN} may satisfy the following conditions:

$$R_{VIN} < \frac{V_F - 16V}{0.5mA}$$

V_F : the voltage of LED.

2. The maximum voltage of VS pin is 2V in order to limit the maximum output current especially in the short circuit condition. The value of R_s can be calculated as below:

$$R_s < \frac{0.2V}{I_{LED}}$$

I_{LED} : the output current of the pre-driver.

3. When the voltage of LED reaches V_{SCP} which is set by the R_{LMT} , DIO8215 pulls down the VIN then turns off the MOSFET. In order to ensure nothing will be damaged in the short circuit condition, the value of R_{LMT} must satisfy the following conditions:

$$V_{OVP} - V_F < V_{SCP} < V_F$$

$$V_{SCP} < V_{INSTART} = R_{VIN} * 0.5mA + 16V$$

$$V_{SCP} = 2V + 40\mu A * R_{LMT}$$

V_{OVP} : the output voltage when the pre-driver is open.

V_{SCP} : the threshold of DIO8215 short circuit protection.

$V_{INSTART}$: the output voltage of the pre-driver when the VIN of DIO8215 is 16V.



DIO8215

4. The value of the capacitor between VC and GND can determine the final amplitude of the current ripple. It should be large enough in order to remove the current ripple of the LED string. However, too large capacitor may slow down the dynamic response. In normal condition, 1 μ F or 2.2 μ F is relatively reasonable.
5. To ensure DIO8215 work properly, the $R_{DS(on)}$ of MOSFET must be less than 3 R_s . The MOSFET will endure a large power shorting the output on the moment, so the appropriate package and $R_{DS(on)}$ of the MOSFET is necessary.
6. When short the LED, there is an overshoot on the drain of the MOSFET. The breakdown voltage of the MOSFET must be higher than V_{OVP} . A diode connected to LED+&LED- can reduce the overshoot when short.

Adaptive 100/120Hz Current Ripple Remover, Max LED Current $\leq 500\text{mA}$



Physical Dimensions: EP-SOIC8

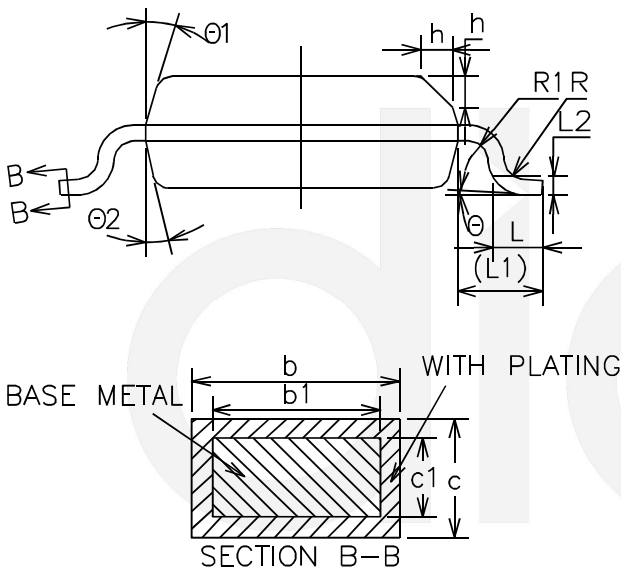
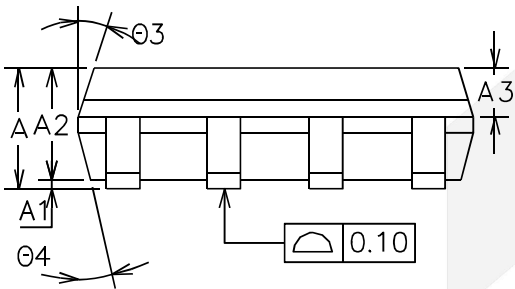
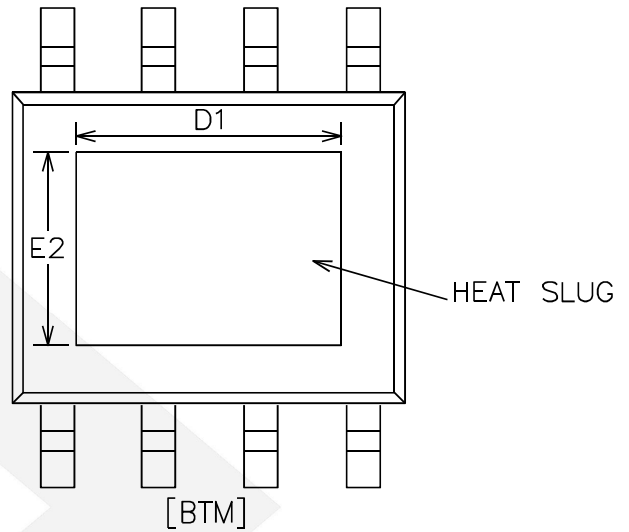
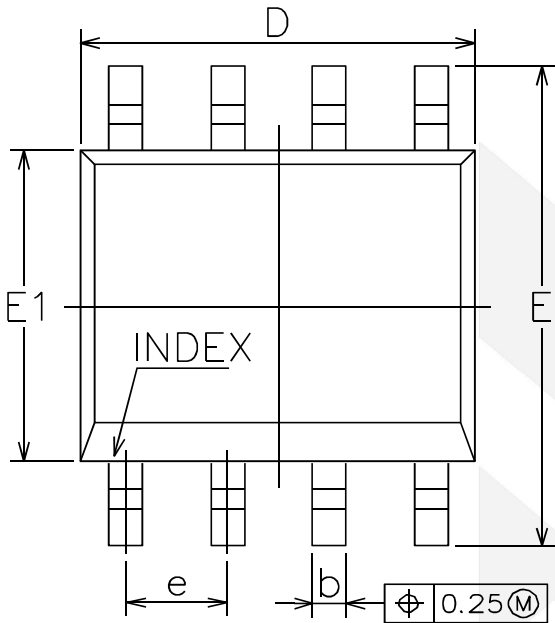

COMMON DIMENSIONS (UNITS OF MEASURE=MILLIMETER)			
Symbol	MIN	NOM	MAX
A	1.35	1.55	1.70
A1	0	0.10	0.15
A2	1.25	1.40	1.65
A3	0.50	0.60	0.70
b	0.38	-	0.51
b1	0.37	0.42	0.47
c	0.17	-	0.25
c1	0.17	0.20	0.23
D	4.80	4.90	5.00
D1	3.10	3.30	3.50
E	5.80	6.00	6.20
E1	3.80	3.90	4.00
E2	2.20	2.40	2.60
e	1.17	1.27	1.37
L	0.45	0.60	0.80
L1	1.04REF		
L2	0.25BSC		
R	0.07	-	-
R1	0.07	-	-
h	0.30	0.40	0.50
θ	0°	-	8°
$\theta 1$	15°	17°	19°
$\theta 2$	11°	13°	15°
$\theta 3$	15°	17°	19°
$\theta 4$	11°	13°	15°



DIO8215

Adaptive 100/120Hz Current Ripple Remover, Max LED Current $\leq 500\text{mA}$

CONTACT US

Dioo is a professional design and sales corporation for high-quality and performance analog semiconductors. The company focuses on industry markets, such as, cell phone, handheld products, laptop, and medical equipment and so on. Dioo's product families include analog signal processing and amplifying, LED drivers and charger IC. Go to <http://www.dioo.com> for a complete list of Dioo product families.

For additional product information, or full datasheet, please contact with our Sales Department or Representatives.

dioo