

DL126TRS/D

Tape & Reel and Packaging Specifications for Small-Signal Transistors, FETs and Diodes

**ON Semiconductor™**<http://onsemi.com>

Excerpted from the ON Semiconductor Small-Signal Transistors, FETs and Diodes Device Data Book, DL126/D.

Embossed Tape and Reel is used to facilitate automatic pick and place equipment feed requirements. The tape is used as the shipping container for various products and requires a minimum of handling. The antistatic/conductive tape provides a secure cavity for the product when sealed with the “peel-back” cover tape.

- Two Reel Sizes Available (7" and 13")
- Used for Automatic Pick and Place Feed Systems
- Minimizes Product Handling
- EIA 481, -1, -2
- SOT-23, SC-59, SC-70/SOT-323, SC-75/SOT-416/SC-90, SC-88/SOT-363, SC-88A/SOT-353, SC-74/TSOP-6, SOD-123, SOD-323 in 8 mm Tape
- SOT-89, SOT-223 in 12 mm Tape
- SO-16 in 16 mm Tape

Use the standard device title and add the required suffix as listed in the option table below (Table 1). Note that the individual reels have a finite number of devices depending on the type of product contained in the tape. Also note the minimum lot size is one full reel for each line item, and orders are required to be in increments of the single reel quantity.

Table 1. EMBOSSED TAPE AND REEL ORDERING INFORMATION

Package	Tape Width (mm)	Pitch mm	Pitch (inch)	Reel Size mm	Reel Size (inch)	Devices Per Reel and Minimum Order Quantity	Device Suffix
SOT-23	8 8	4		178 330	(7) (13)	3,000 10,000	T1 T3
SC-59	8	4		178	(7)	3,000	T1
SC-70, SOT-323	8 8	4		178 330	(7) (13)	3,000 10,000	T1 T3
SC-75, SOT-416, SC-90	8	4		178	(7)	3,000	T1
SC-88, SOT-363	8	4		178	(7)	3,000	T1
SC-88A, SOT-353	8	4		178	(7)	3,000	T1
SC-74, TSOP-6	8	4		178	(7)	3,000	T1
SOD-123	8 8	4		178 330	(7) (13)	3,000 10,000	T1 T3
SOD-323	8	4		178	(7)	3,000	T1
SOT-89	12	8		178	(7)	1,000	T1
SOT-223	12 12	8		178 330	(7) (13)	1,000 4,000	T1 T3
SO-16	16 16	8		178 330	(7) (13)	500 2,500	R1 R2

DL126TRS/D

EMBOSSED TAPE AND REEL DATA FOR DISCRETES

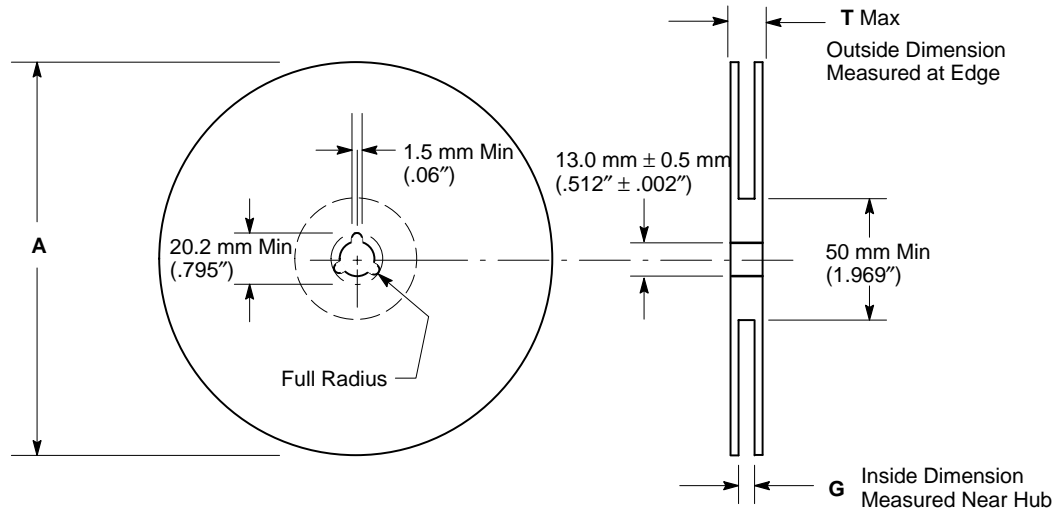

Size	A Max	G	T Max
8 mm	330 mm (12.992")	8.4 mm + 1.5 mm, -0.0 (.33" + .059", -0.00)	14.4 mm (.56")
12 mm	330 mm (12.992")	12.4 mm + 2.0 mm, -0.0 (.49" + .079", -0.00)	18.4 mm (.72")
16 mm	360 mm (14.173")	16.4 mm + 2.0 mm, -0.0 (.646" + .078", -0.00)	22.4 mm (.882")
24 mm	360 mm (14.173")	24.4 mm + 2.0 mm, -0.0 (.961" + .070", -0.00)	30.4 mm (1.197")

Figure 1. Reel Dimensions

Metric Dimensions Govern — English are in parentheses for reference only

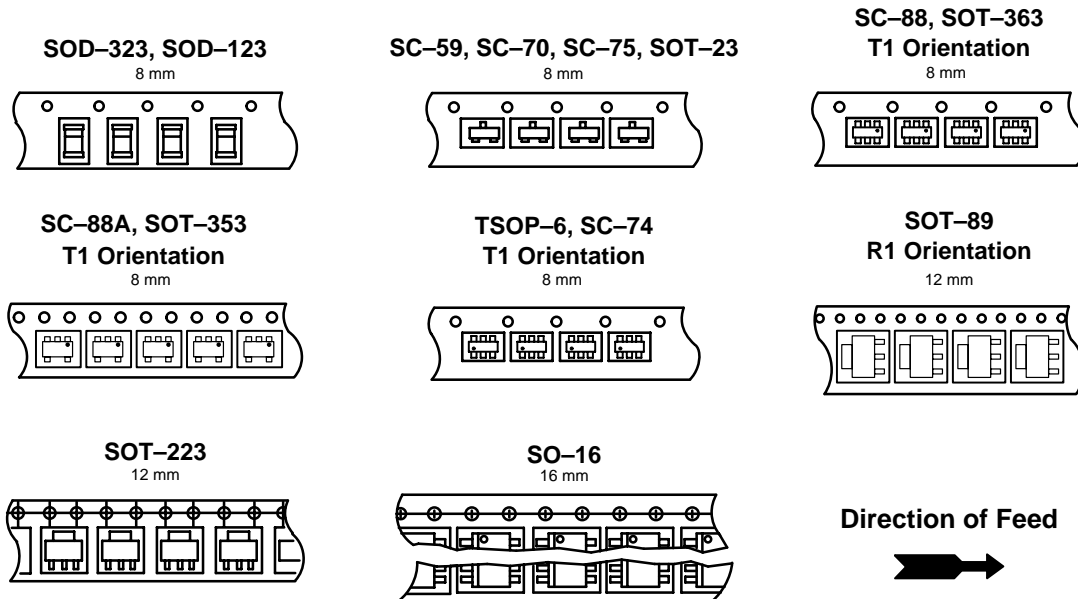

Figure 2. Typical Reel Orientations

Figure 3. CARRIER TAPE SPECIFICATIONS

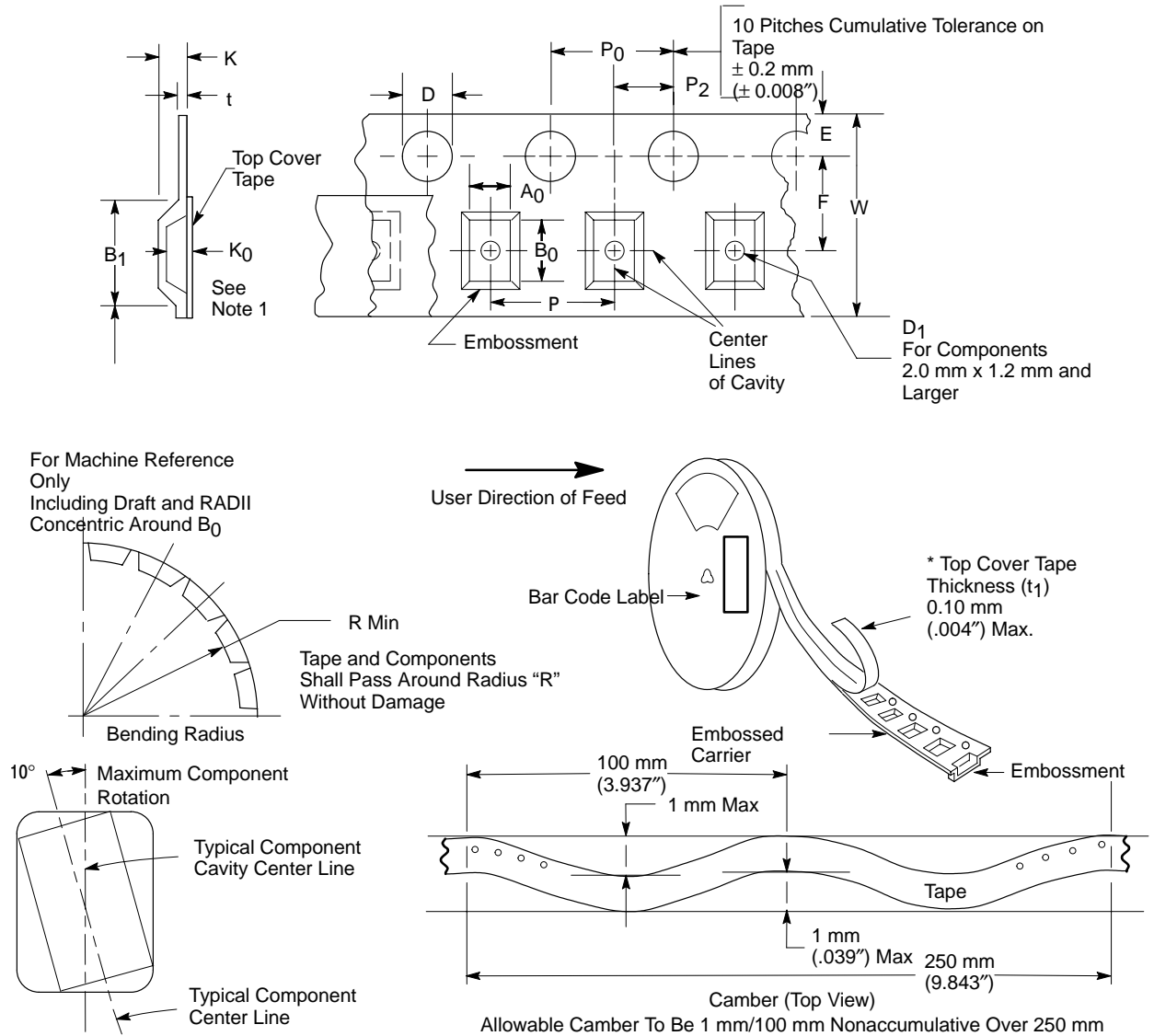

Table 2. DIMENSIONS

Tape Size	B ₁ Max	D	D ₁	E	F	K	P ₀	P ₂	R Min	T Max	W Max
8 mm	4.55 mm (.179")	1.5±0.1 mm -0.0 (.059±.004")	1.0 Min (.039")	1.75±0.1 mm (.069±.004")	3.5±0.05 mm (.138±.002")	2.4 mm Max (.094")	4.0±0.1 mm (.157±.004")	2.0±0.1 mm (.079±.002")	25 mm (.98")	0.6 mm (.024")	8.3 mm (.327")
12 mm	8.2 mm (.323")		1.5 mm Min (.060")		5.5±0.05 mm (.217±.002")	6.4 mm Max (.252")					12±.30 mm (.470±.012")
16 mm	12.1 mm (.476")				7.5±0.10 mm (.295±.004")	7.9 mm Max (.311")					16.3 mm (.642")
24 mm	20.1 mm (.791")				11.5±0.1 mm (.453±.004")	11.9 mm Max (.468")					24.3 mm (.957")

Metric dimensions govern — English are in parentheses for reference only.

- A₀, B₀, and K₀ are determined by component size. The clearance between the components and the cavity must be within 0.05 mm min. to 0.50 mm max., the component cannot rotate more than 10° within the determined cavity.
- If B₁ exceeds 4.2 mm (0.165) for 8 mm embossed tape, the tape may not feed through all tape feeders.
- Pitch information is contained in Table 1. Embossed Tape and Reel Ordering Information on pg. 1.

TO-92 EIA, IEC, EIAJ Radial Tape in Fan Fold Box or On Reel

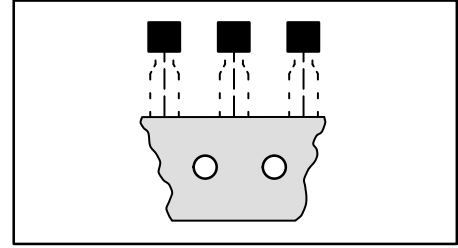

Radial tape in fan fold box or on reel of the reliable TO-92 package are the best methods of capturing devices for automatic insertion in printed circuit boards. These methods of taping are compatible with various equipment for active and passive component insertion.

- Available in Fan Fold Box
- Available on 365 mm Reels
- Accommodates All Standard Inserters
- Allows Flexible Circuit Board Layout
- 2.5 mm Pin Spacing for Soldering
- EIA-468, IEC 286-2, EIAJ RC1008B

Ordering Notes:

When ordering radial tape in fan fold box or on reel, specify the style per Figures 4 through 7. Add the suffix “RLR” and “Style” to the device title, i.e. MPS3904RLRA. This will be a standard MPS3904 leadformed, radial taped and supplied on a reel per Figure 4.

Fan Fold Box Information — Order in increments of 2000.

Reel Information — Order in increments of 2000.

US/European Suffix Conversions

US	EUROPE
RLRA	RL
RLRE	RL1
RLRM	ZL1

Package Suffixes

Device Suffix	Leadform Type	Shipping
(None)	Straight	5000/Bag
RLRA	Leadformed	2000/Tape & Reel
RLRE	Leadformed	2000/Tape & Reel
RLRM	Leadformed	2000/Fan Fold Box
RLRP	Leadformed	2000/Fan Fold Box

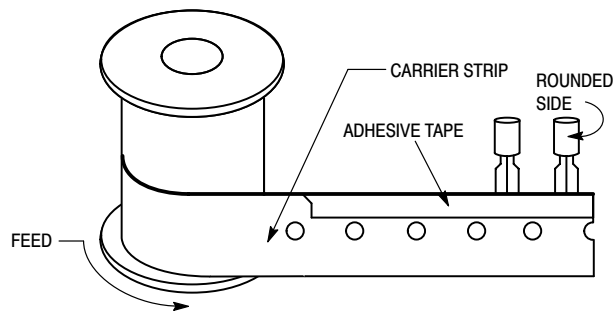

Rounded side of transistor and adhesive tape visible.

Figure 4. Style A

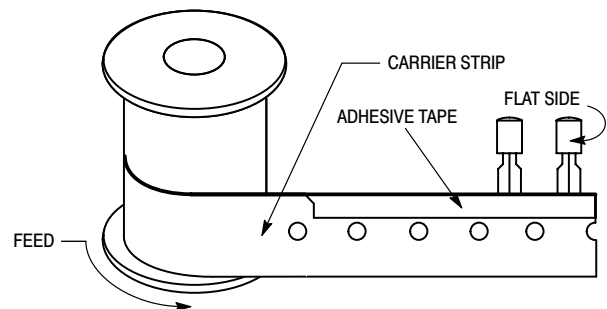

Flat side of transistor and adhesive tape visible.

Figure 5. Style E

DL126TRS/D

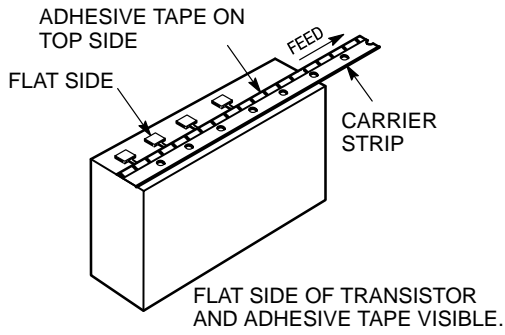

Style M fan fold box is equivalent to styles E and F of reel pack dependent on feed orientation from box.

Figure 6. Style M

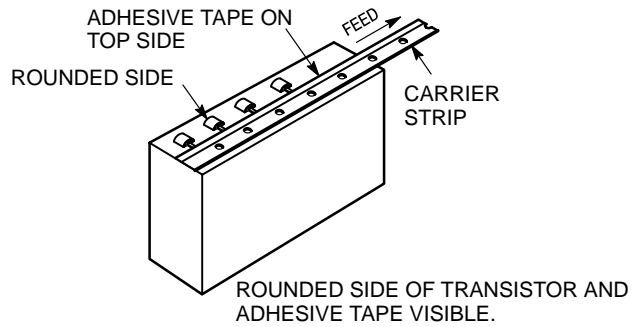

Style P fan fold box is equivalent to styles A and B of reel pack dependent on feed orientation from box.

Figure 7. Style P

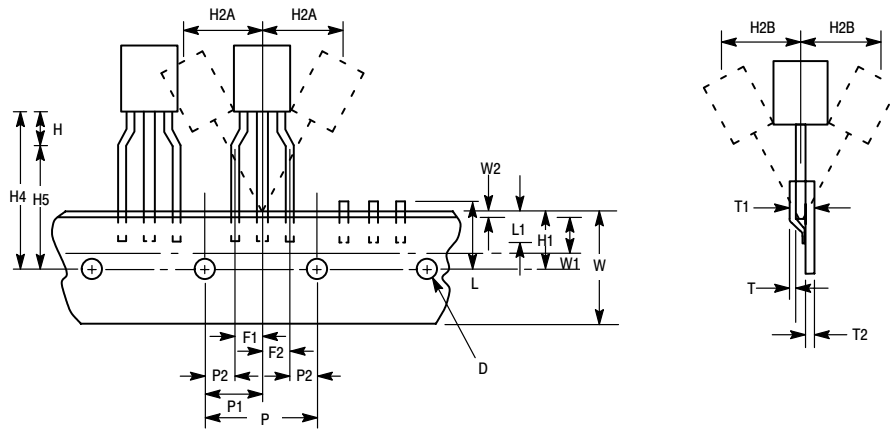

Figure 8. Device Positioning on Tape

Dimensions for Device Positioning on Tape for Fan Fold Box

Symbol	Item	Specification			
		Inches		Millimeter	
		Min	Max	Min	Max
D	Tape Feedhole Diameter	0.1496	0.1653	3.8	4.2
D2	Component Lead Thickness Dimension	0.015	0.020	0.38	0.51
F1, F2	Component Lead Pitch	0.0945	0.110	2.4	2.8
H	Bottom of Component to Seating Plane	.059	.156	1.5	4.0
H1	Feedhole Location	0.3346	0.3741	8.5	9.5
H2A	Deflection Left or Right	0	0.039	0	1.0
H2B	Deflection Front or Rear	0	0.051	0	1.0
H4	Feedhole to Bottom of Component	0.7086	0.768	18	19.5
H5	Feedhole to Seating Plane	0.610	0.649	15.5	16.5
L	Defective Unit Clipped Dimension	0.3346	0.433	8.5	11
L1	Lead Wire Enclosure	0.09842	—	2.5	—
P	Feedhole Pitch	0.4921	0.5079	12.5	12.9
P1	Feedhole Center to Center Lead	0.2342	0.2658	5.95	6.75
P2	First Lead Spacing Dimension	0.1397	0.1556	3.55	3.95
T	Adhesive Tape Thickness	0.06	0.08	0.15	0.20

Dimensions for Device Positioning on Tape for Fan Fold Box

Symbol	Item	Specification			
		Inches		Millimeter	
		Min	Max	Min	Max
T1	Overall Taped Package Thickness	—	0.0567	—	1.44
T2	Carrier Strip Thickness	0.014	0.027	0.35	0.65
W	Carrier Strip Width	0.6889	0.7481	17.5	19
W1	Adhesive Tape Width	0.2165	0.2841	5.5	6.3
W2	Adhesive Tape Position	.0059	0.01968	.15	0.5

NOTES:

1. Maximum alignment deviation between leads not to be greater than 0.2 mm.
2. Defective components shall be clipped from the carrier tape such that the remaining protrusion (L) does not exceed a maximum of 11 mm.
3. Component lead to tape adhesion must meet the pull test requirements established in Figures 5, 6 and 7.
4. Maximum non-cumulative variation between tape feed holes shall not exceed 1 mm in 20 pitches.
5. Holddown tape not to extend beyond the edge(s) of carrier tape and there shall be no exposure of adhesive.
6. No more than 1 consecutive missing component is permitted.
7. A tape trailer and leader, having at least three feed holes is required before the first and after the last component.
8. Splices will not interfere with the sprocket feed holes.

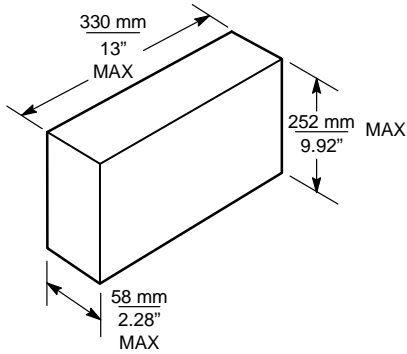
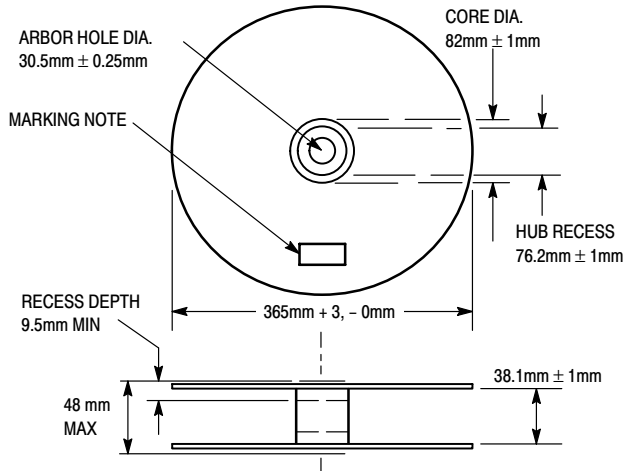

Figure 9. Fan Fold Box Dimensions



Material used must not cause deterioration of components or degrade lead solderability

Figure 10. Reel Dimensions

ADHESION PULL TESTS

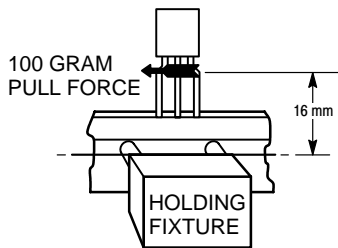

The component shall not pull free with a 300 gram load applied to the leads for 3 ± 1 second.

Figure 11. Test #1

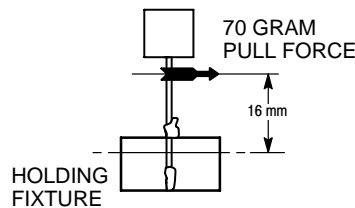

The component shall not pull free with a 70 gram load applied to the leads for 3 ± 1 second.

Figure 12. Test #2

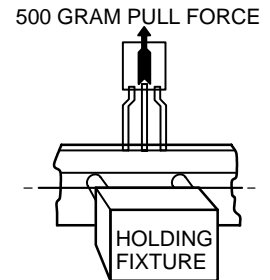

There shall be no deviation in the leads and no component leads shall be pulled free of the tape with a 500 gram load applied to the component body for 3 ± 1 second.

Figure 13. Test #3

Notes

Thermal Clad is a trademark of the Bergquist Company.

ON Semiconductor and  are trademarks of Semiconductor Components Industries, LLC (SCILLC). SCILLC reserves the right to make changes without further notice to any products herein. SCILLC makes no warranty, representation or guarantee regarding the suitability of its products for any particular purpose, nor does SCILLC assume any liability arising out of the application or use of any product or circuit, and specifically disclaims any and all liability, including without limitation special, consequential or incidental damages. "Typical" parameters which may be provided in SCILLC data sheets and/or specifications can and do vary in different applications and actual performance may vary over time. All operating parameters, including "Typicals" must be validated for each customer application by customer's technical experts. SCILLC does not convey any license under its patent rights nor the rights of others. SCILLC products are not designed, intended, or authorized for use as components in systems intended for surgical implant into the body, or other applications intended to support or sustain life, or for any other application in which the failure of the SCILLC product could create a situation where personal injury or death may occur. Should Buyer purchase or use SCILLC products for any such unintended or unauthorized application, Buyer shall indemnify and hold SCILLC and its officers, employees, subsidiaries, affiliates, and distributors harmless against all claims, costs, damages, and expenses, and reasonable attorney fees arising out of, directly or indirectly, any claim of personal injury or death associated with such unintended or unauthorized use, even if such claim alleges that SCILLC was negligent regarding the design or manufacture of the part. SCILLC is an Equal Opportunity/Affirmative Action Employer.

PUBLICATION ORDERING INFORMATION

Literature Fulfillment:

Literature Distribution Center for ON Semiconductor
P.O. Box 5163, Denver, Colorado 80217 USA
Phone: 303-675-2175 or 800-344-3860 Toll Free USA/Canada
Fax: 303-675-2176 or 800-344-3867 Toll Free USA/Canada
Email: ONlit@hibbertco.com

N. American Technical Support: 800-282-9855 Toll Free USA/Canada

JAPAN: ON Semiconductor, Japan Customer Focus Center
4-32-1 Nishi-Gotanda, Shinagawa-ku, Tokyo, Japan 141-0031
Phone: 81-3-5740-2700
Email: r14525@onsemi.com

ON Semiconductor Website: <http://onsemi.com>

For additional information, please contact your local Sales Representative.