

**DLC Display Co., Limited**

德爾西顯示器有限公司



MODEL No:DLC0230AZG

TEL: 86-755-86029824

FAX: 86-755-86029827

E-MAIL: [sales@dlcdisplay.com](mailto:sales@dlcdisplay.com)

WEB: [www.dlcdisplay.com](http://www.dlcdisplay.com)



### Record of Revision

Date	Revision No.	Summary
2013-03-15	1.0	Rev 1.0 was issued
2015-08-28	2.0	Update backlight and interface

### 1. Scope

This data sheet is to introduce the specification of DLC0230AZG active matrix TFT module. It is composed of a color TFT-LCD panel, driver ICs, FPC and a backlight unit. The 2.3" display area contains 320(RGB) x240 pixels.

### 2. Application

Digital equipments which need color display, mobile phone, mobile navigator/video systems.

### 3. General Information

Item	Contents	Unit
Size	2.3	inch
Resolution	320(RGB) x 240	/
Interface	CPU	/
Technology type	a-Si TFT	/
Pixel pitch	0.1461x0.1461	mm
Pixel Configuration	320xRGBx240 Pixels	
Outline Dimension (W x H x D)	50.90X45.80X2.35	mm
Active Area	46.752X35.064	mm
Display Mode	Transmissive, Normally White	/
Backlight Type	LED	/
Driver IC	ILI9342C	/
Weight	TBD	g

### 4. Outline Drawing

Pin	Pin Name
1	LEDKA
2	LEDK1
3	LEDK2
4	LEDK3
5	LEDK4
6	GND
7	RESET
8	GND
9	GND
10	GND
11	GND
12	GND
13	GND
14	GND
15	GND
16	DB7
17	DB6
18	DB5
19	DB4
20	DB3
21	DB2
22	DB1
23	DB0
24	NC
25	RD
26	WR
27	RS
28	CS
29	IOVCC
30	VCC
31	VCC
32	GND
33	NC
34	NC
35	NC
36	NC

For reference

**IF=15\*4mA VF=3.2V**

LEDK  
LEDK  
LEDK  
LEDK

LEDK4  
LEDK3  
LEDK2  
LEDK1

**NOTE:**

- 1 DISPLAY TYPE : 2.3" QVGA TFT
- 2 VIEWING DIRECTION : 6 O' CLOCK
- 3 LCD DRIVER : ILI9342C
- 4 OPERATING TEMP : -20° C---+70° C
- 5 STORAGE TEMP : -30° C---+80° C
- 6 RoHS Compliant

DLC Display Co., Limited  
www.dlcdisplay.com

DRAWN BY:	TITLE: DLC0230AZG	 SCALE: UNIT: mm
CHECKED BY:	DWG NO:	
APPROVED BY:	DWG NAME:	
CONFIRMED BY:	SHEET NO: OF	

## 5. Interface signals

No	Symbol	Description	Remarks
1	LEDA	Anode pin of backlight	
2	LEDK1	Cathode pin OF backlight	
3	LEDK2	Cathode pin OF backlight	
4	LEDK3	Cathode pin OF backlight	
5	LEDK4	Cathode pin OF backlight	
6	GND	Power Ground	
7	RESET	Input RESET signal	
8	GND	Power Ground	
9	GND	Power Ground	
10	GND	Power Ground	
11	GND	Power Ground	
12	GND	Power Ground	
13	GND	Power Ground	
14	GND	Power Ground	
15	GND	Power Ground	
16	DB7	Data input/output	
17	DB6	Data input/output	
18	DB5	Data input/output	
19	DB4	Data input/output	
20	DB3	Data input/output	
21	DB2	Data input/output	
22	DB1	Data input/output	
23	DB0	Data input/output	
24	NC	Not Connected	
25	RD	A read strobe signal and enables an operation to read out data when the signal is low.	
26	WR	A write strobe signal and enables an operation to write data when the signal is low.	
27	RS	A register select signal	
28	CS	A chip select signal	
29	IOVCC	IO Pad and Digital power supply	
30	VCC	Power supply	
31	VCC	Power supply	
32	GND	Power Ground	
33	NC	Not Connected	
34	NC	Not Connected	
35	NC	Not Connected	
36	NC	Not Connected	

## 6. Absolute maximum Ratings

### 6.1. Electrical Absolute max. ratings

Parameter	Symbol	MIN	MAX	Unit	Remark
Supply voltage for logic	VCC	-0.3	4.6	V	
Input voltage for logic	VIN	-0.3	VCC +0.3	V	
Supply current	ILCD	--	20	mA	

### 6.2. Environment Conditions

Item	Symbol	MIN	MAX	Unit	Remark
Operating Temperature	TOPR	-20	70	°C	
Storage Temperature	TSTG	-30	80	°C	

## 7. Electrical Specifications

### 7.1 Electrical characteristics

GND=0V, Ta=25°C

Item	Symbol	MIN	TYP	MAX	Unit	Remark
Logic Supply Voltage	IOVCC	1.65	1.8/2.8	3.3	V	
Analog Supply Voltage	VCC	2.3	2.8	3.3	V	
Input Signal Voltage	V <sub>IL</sub>	0	--	0.2xVDD	V	DB0~DB7, WR, RD,RS,CS,RESET
	V <sub>IH</sub>	0.8xVCC	--	VCC	V	
Output Signal Voltage	V <sub>OL</sub>	--	--	0.2xVCC	V	
	V <sub>OH</sub>	0.8xVCC	--	VCC	V	
(Panel+ LSI) Power Consumption	Black Mode (60Hz)	--	TBD	--	mW	
	Sleeping Mode	--	TBD	--	uW	

### 7.2 LED Backlight

Ta=25°C

Item	Symbol	MIN	TYP	MAX	Unit	Remark
Supply current	IF	--	60	--	mA	
Supply voltage	VF	--	3.2	--	V	
LED life time	--	--	(25,000)	--	Hrs	

Note1:

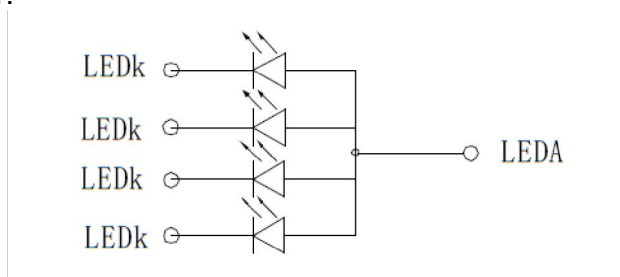

### 7.3 Schematic of LCD module system

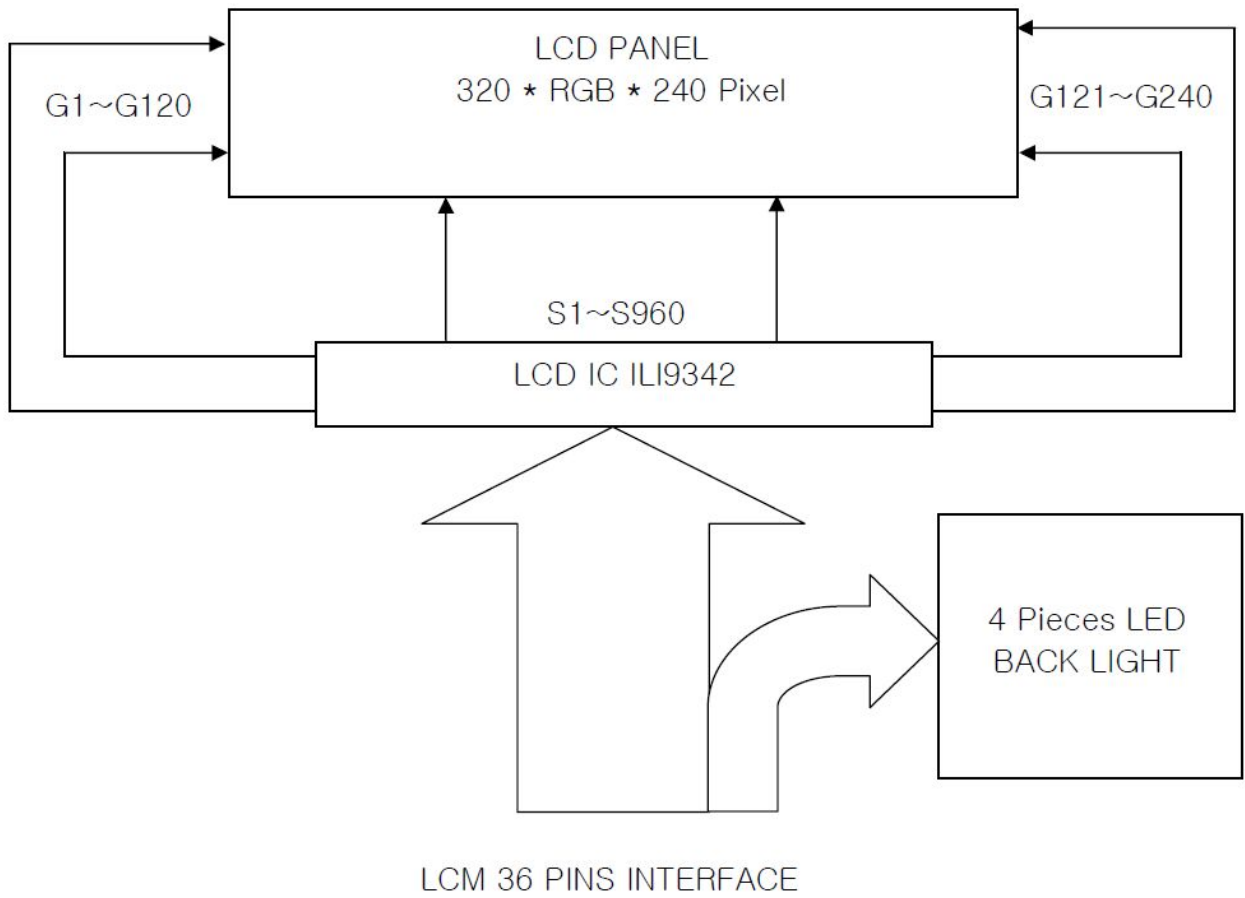



## 8. Command/AC Timing

### 8.1 Interface Timing Parameters

Signal	Symbol	Parameter	Min	Max	Unit	Description
RS	t <sub>AST</sub>	Address setup time	0	-	ns	
	t <sub>AHT</sub>	Address hold time(Write/Read)	10	-		
CS	t <sub>CHW</sub>	Chip select "H"pulse width	0	--	ns	
	t <sub>CS</sub>	Chip elect set up time (Write)	15			
	t <sub>RCS</sub>	Chip select setup time (Read ID)	45			
	t <sub>RCSFM</sub>	Chip select setup time (Read FM)	355			
	t <sub>CSF</sub>	Chip select wait time(Write/Read)	10			
WR	t <sub>WC</sub>	Write cycle	65	--	ns	
	t <sub>WRH</sub>	Control pulse "H" duration	15			
	t <sub>WRL</sub>	Control pulse "L" duration	15			
RD(ID)	t <sub>RC</sub>	Read cycle (ID)	160	--	ns	When read ID data
	t <sub>RDH</sub>	Control pulse "H" duration(ID)	90			
	t <sub>RDL</sub>	Control pulse "L" duration (ID)	45			
RD(FM)	t <sub>RCFM</sub>	Read cycle (FM)	450	--	ns	When read from frame memory
	t <sub>RDHFM</sub>	Control pulse "H" duration(FM)	90			
	t <sub>RDLFM</sub>	Control pulse "L" duration (FM)	355			
DB[15:0],	t <sub>DST</sub>	Data setup time	10	-	ns	For max C <sub>L</sub> =30pF For min C <sub>L</sub> =8pF
	t <sub>DHT</sub>	Data hold time	10	-		
	t <sub>RAT</sub>	Read access time (ID)	-	40		
	t <sub>RATFM</sub>	Read access time (FM)	-	340		
	t <sub>ODH</sub>	Output disable time	20	80		

8.2 Interface Characteristics

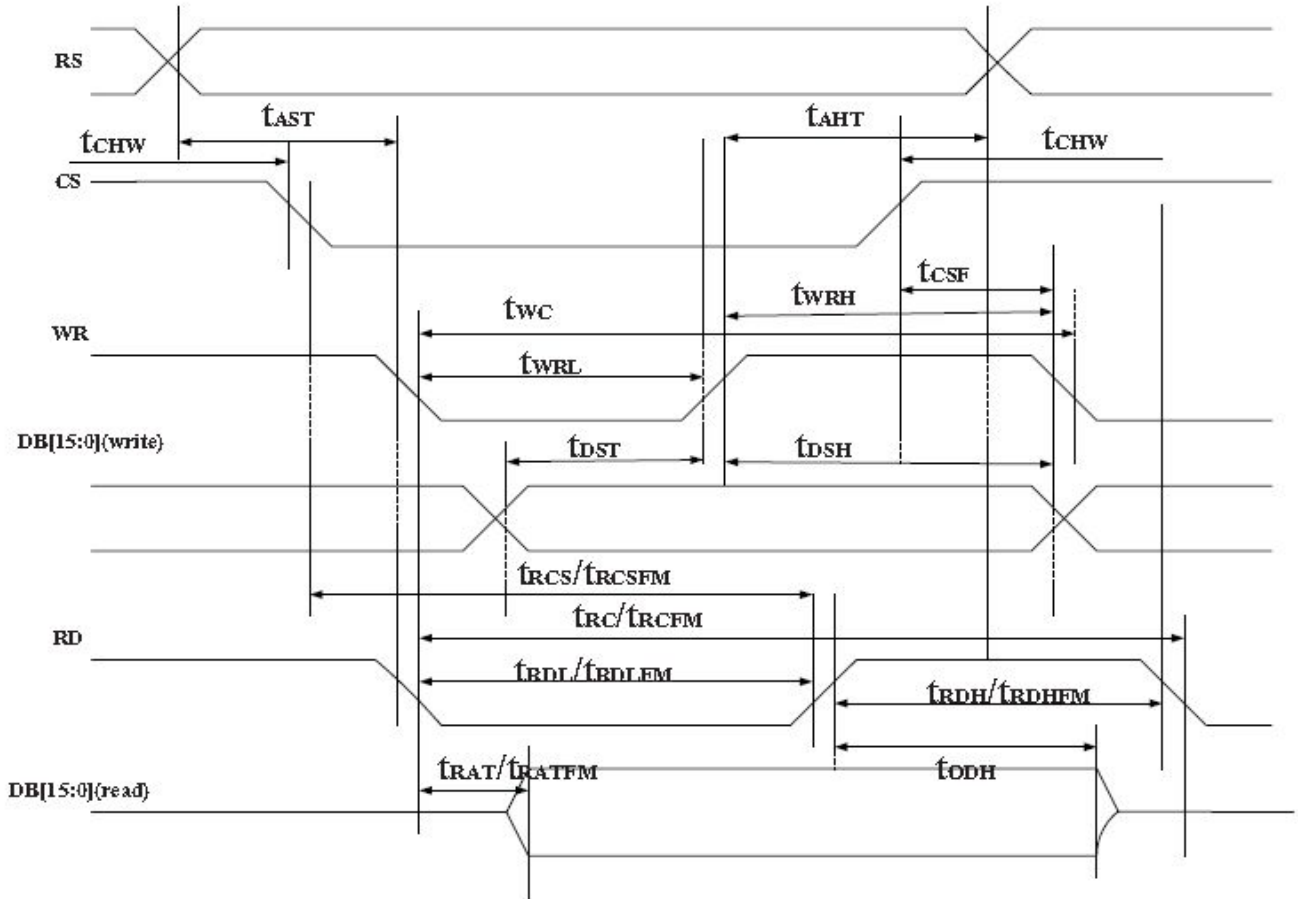

### 8.3 Interface Register write/read timing

#### 8.3.1 System Bus Interface Register or GRAM Write Timing

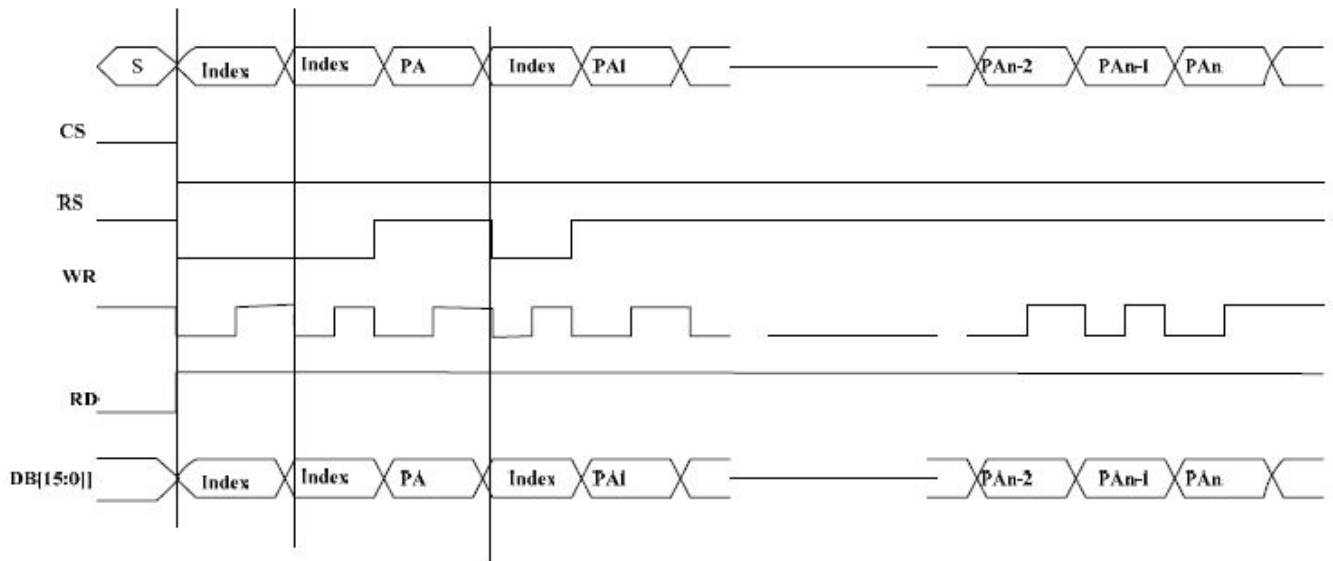

Index: write command code  
PA :write parameter or GRAM Data

#### 8.3.2 System Bus Interface Register or GRAM Read Timing

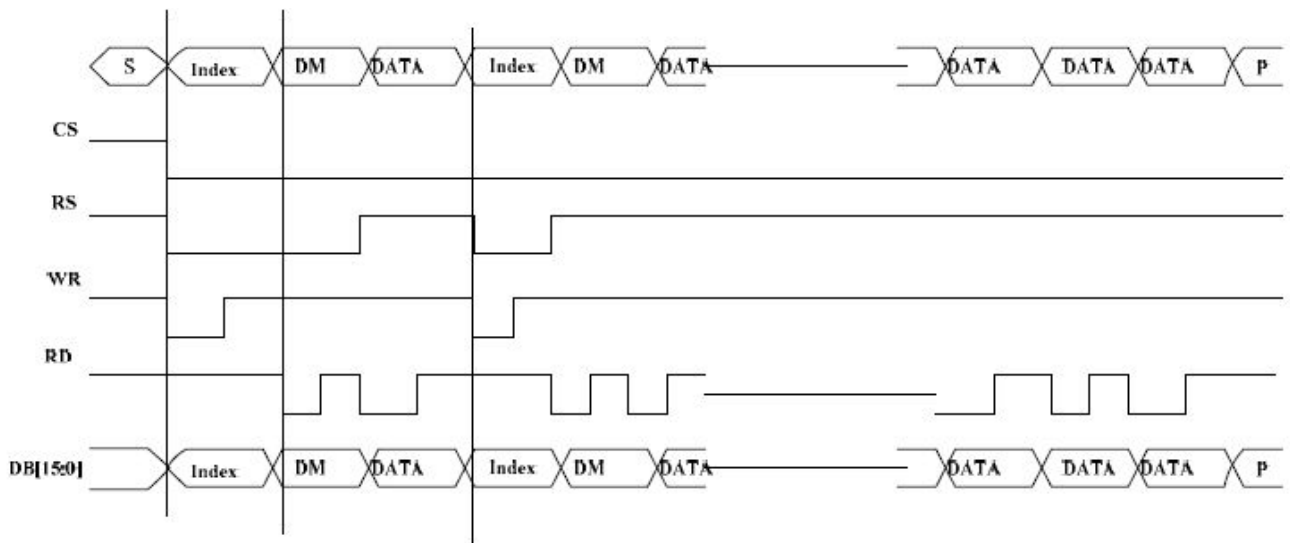

Index: write command code  
PA :write parameter or GRAM Data  
DM: Dummy Read

### 8.4 GRAM Write/Read Data Format

#### 8.4.1 Write data for RGB 5-6-5 (65k colors) bits input in 16-bit parallel Interface

65k Color Data	DCX	DB 17	DB 16	DB 15	DB 14	DB 13	DB 12	DB 11	DB 10	DB 9	DB 8	DB 7	DB 6	DB 5	DB 4	DB 3	DB 2	DB 1	DB 0	GRAM Write
MEMWR	0	x	x	x	x	x	x	x	x	x	x	GRAM Write command code								-
1st write	1	x	x	R14	R13	R12	R11	R10	G15	G14	G13	G12	G11	G10	B14	B13	B12	B11	B10	1st pixel (R1/G1/B1)
2nd write	1	x	x	R24	R23	R22	R21	R20	G25	G24	G23	G22	G21	G20	B24	B23	B22	B21	B20	2nd pixel (R2/G2/B2)

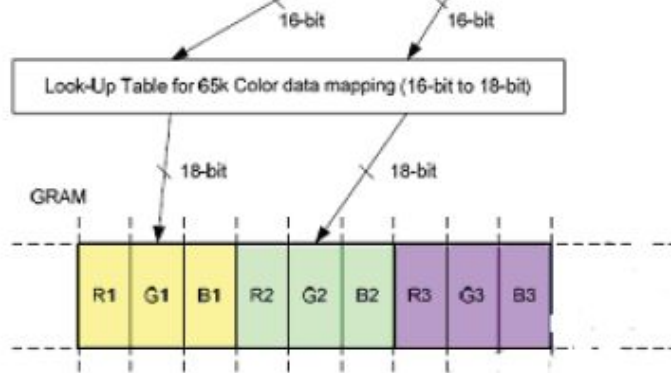

#### 8.4.2 Write data for RGB 5-6-5 (262k colours) bits input in 16-bit parallel Interface

262K Color Data	DCX	DB 17	DB 16	DB 15	DB 14	DB 13	DB 12	DB 11	DB 10	DB 9	DB 8	DB 7	DB 6	DB 5	DB 4	DB 3	DB 2	DB 1	DB 0	GRAM Write
MEMWR	0	x	x	x	x	x	x	x	x	x	x	GRAM Write command code								-
1st write	1	x	x	R15	R14	R13	R12	R11	R10	x	x	G15	G14	G13	G12	G11	G10	x	x	1st pixel (R1/G1/B1)
2nd write	1	x	x	D15	D14	D13	D12	D11	D10	x	x	R25	R24	R23	R22	R21	R20	x	x	-
3rd write	1	x	x	Q25	Q24	Q23	Q22	Q21	Q20	x	x	B25	B24	B23	B22	B21	B20	x	x	2nd pixel (R2/G2/B2)

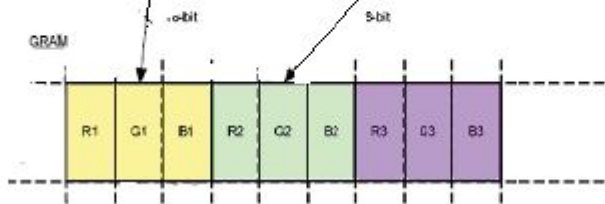

8.5 Reset Timing Characteristics

a. Reset Input Timing

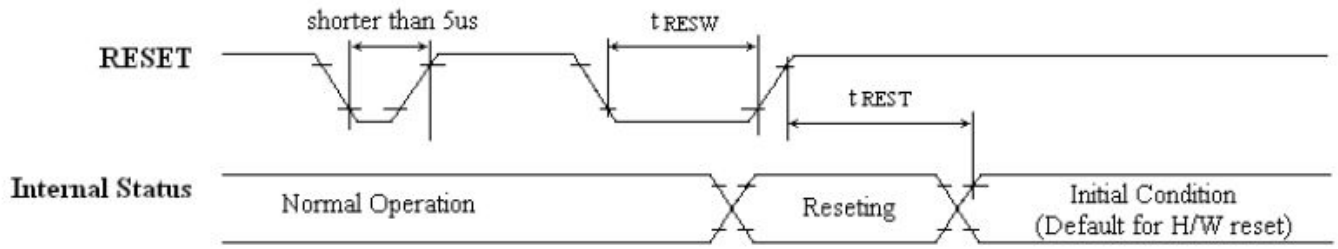

Signal	Parameter	Related pins	Min	Max	Unit	note
tRESW	Reset low pulse width	RESET	10	-	µs	-
tREST	Reset complete time	-	--	5	ms	When reset Applied during "Sleep In mode"
		-	--	120	ms	When reset Applied during "Sleep Out mode"

Note:

RESET Pulse	Action
Shorter than 5µs	Reset Rejected
Longer than 10µs	Reset
Between 5µs and 10µs	Reset Start

### 8.6 Power On/Off Sequence

#### a. Power On Sequence

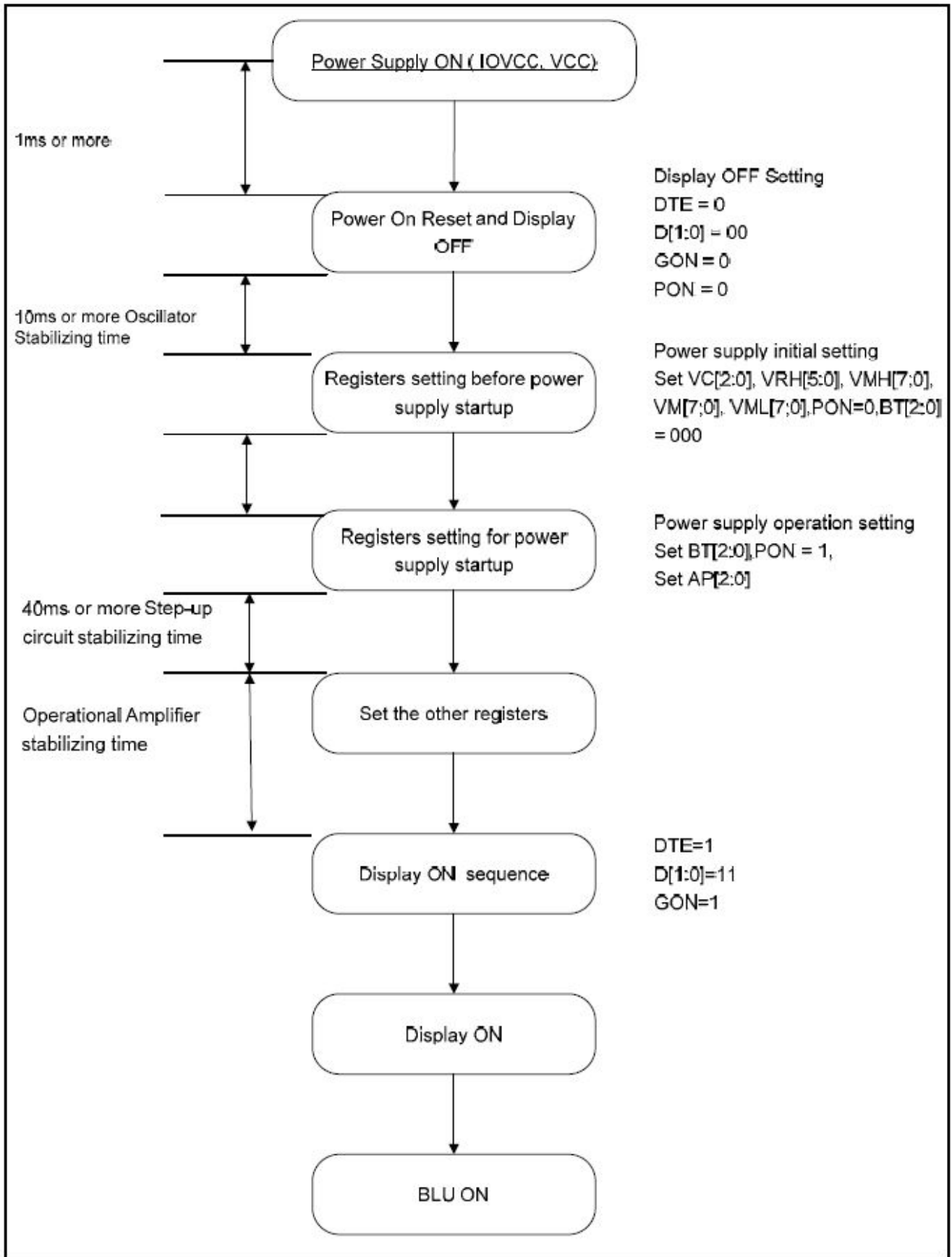

## b. Power Off Sequence

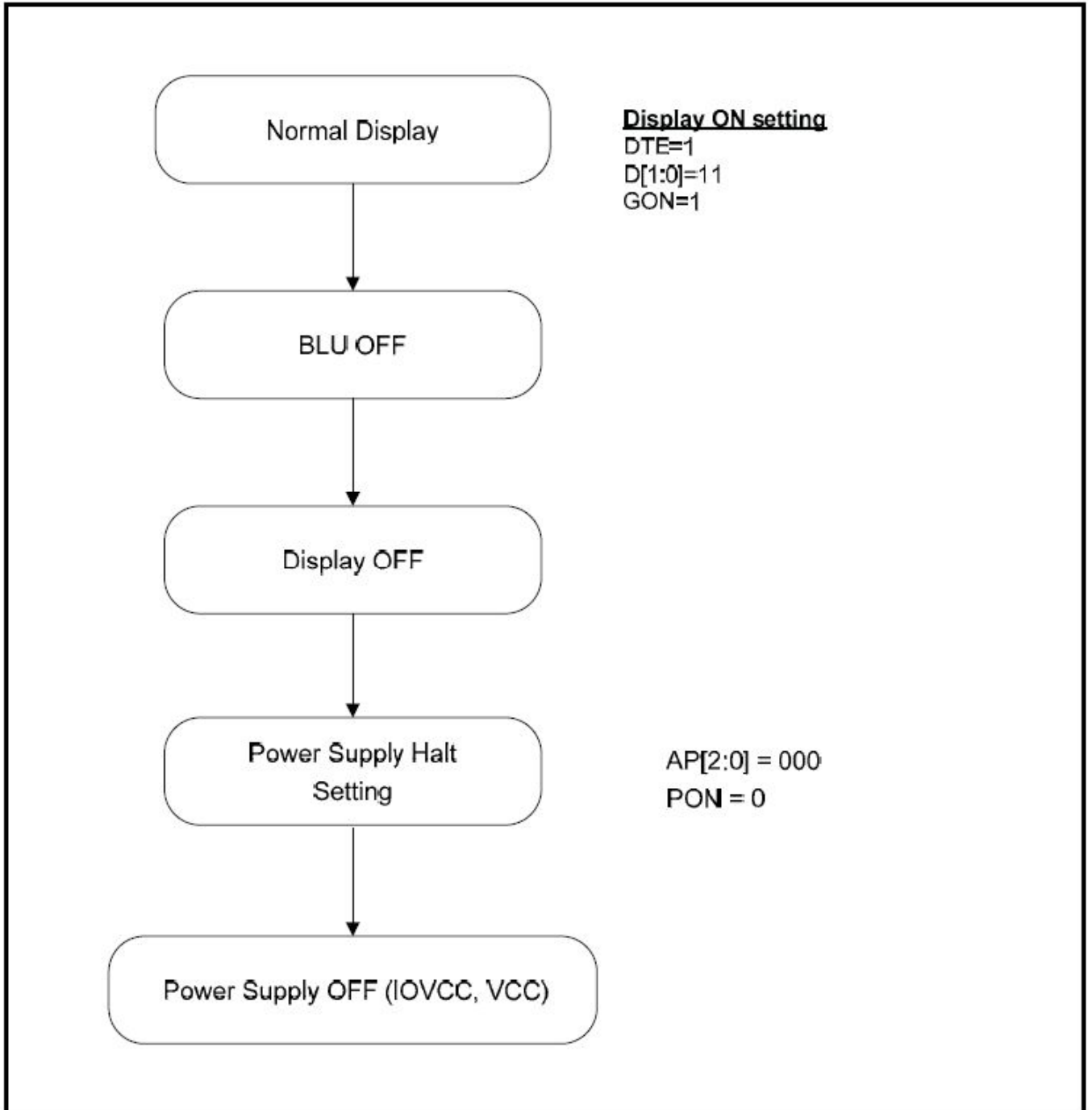

## 9. Optical Specification

Ta=25°C

Item	Symbol	Condition	Min	Typ.	Max.	Unit	Remark
Contrast Ratio	CR	$\theta=0^\circ$	-	500	-		Note1 Note2
Response Time	Ton/ Toff	25°C	-	25	-	ms	Note1 Note3
View Angles	$\Theta T$	CR $\geq 10$	-	60	-	Degree	Note 4
	$\Theta B$		-	50	-		
	$\Theta L$		-	60	-		
	$\theta R$		-	60	-		
Chromaticity	White	x	Brightness is on	Typ-0.05	Tpy+0.05		Note5, Note1
		y					
	RED	x					
		y					
	GREEN	x					
		y					
	BLUE	x					
		y					
NTSC	$\delta L$		-	50	-	%	Note5
Uniformity	U		-	80	-	%	Note1 Note6
Luminance	L		-	200	-	cd/m <sup>2</sup>	Note1 Note7

Test condition: Vf=3.2V, If=60mA ,the ambient temperature is 25°C.

Note 1: Definition of optical measurement system.

Temperature = 25°C(±3°C)

LED back-light: ON, Environment brightness < 150 lx

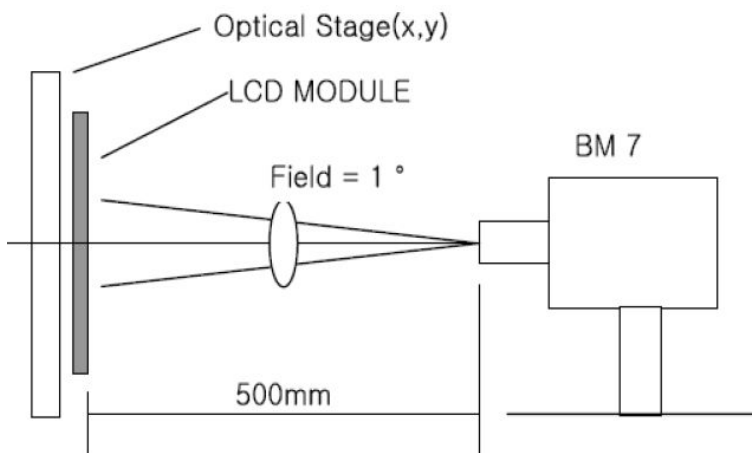



Note 2: Contrast ratio is defined as follow:

$$\text{Contrast Ratio} = \frac{\text{Surface Luminance with all white pixels}}{\text{Surface Luminance with all black pixels}}$$

Note 3: Response time is defined as follow:

Response time is the time required for the display to transition from black to white (Rise Time,  $T_r$ ) and from white to black (Decay Time,  $T_f$ ).

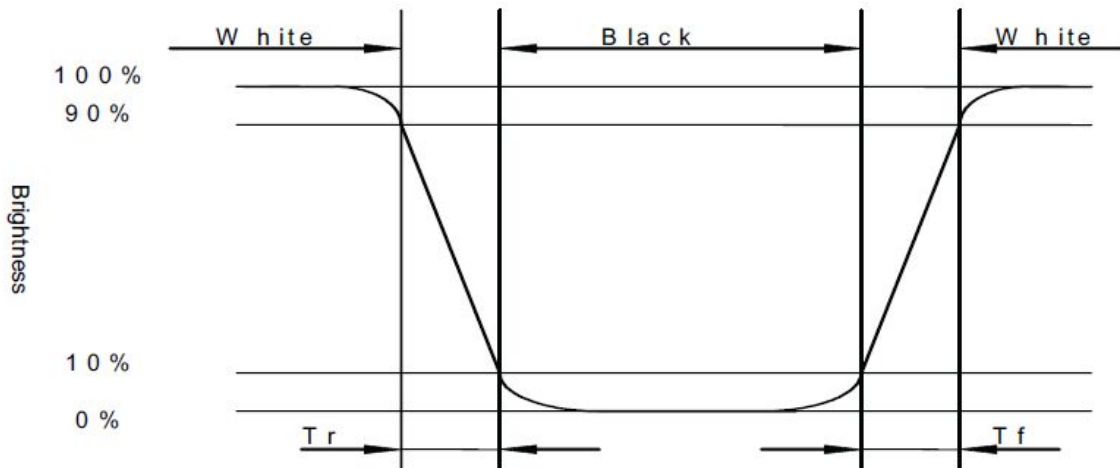

Note 4: Viewing angle range is defined as follow:

Viewing angle is measured at the center point of the LCD.

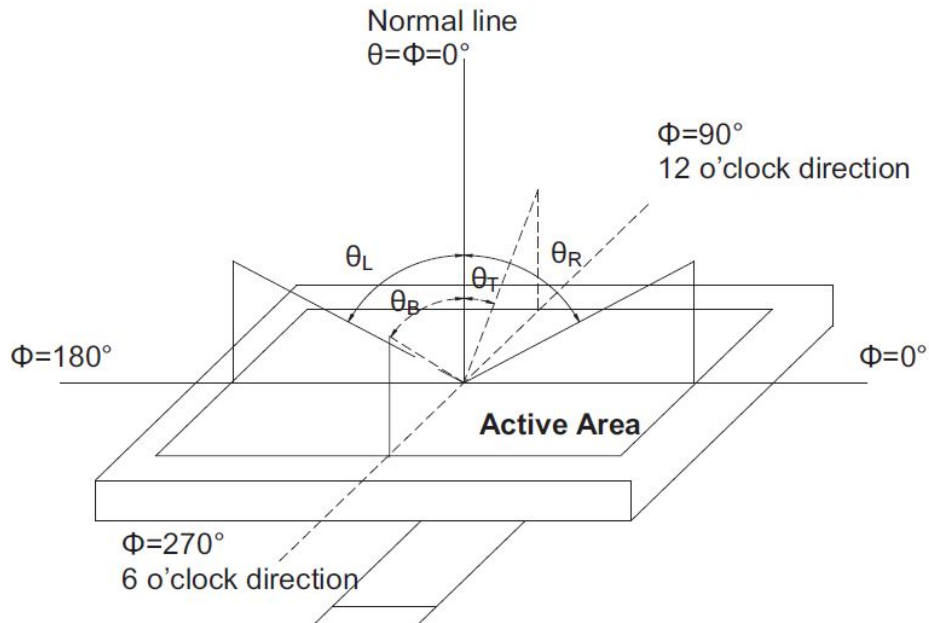

Note 5: Color chromaticity is defined as follow: (CIE1931)

Color coordinates measured at center point of LCD.

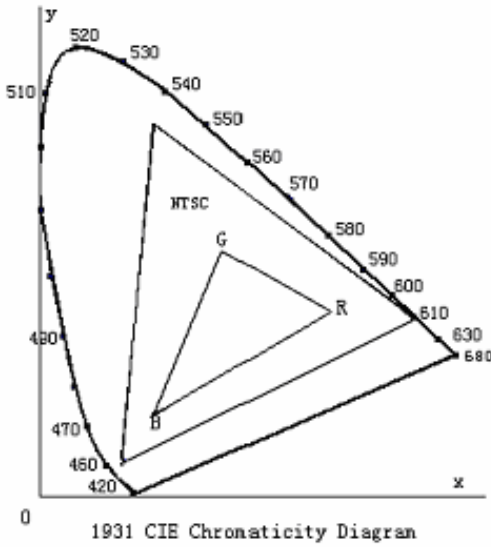

$$S = \frac{\text{area of RGB triangle}}{\text{area of NTSC triangle}} \times 100\%$$

Note 6: Luminance is defined as follow:

Luminance is defined as the brightness of all pixels “White” at the center of display area on optimum contrast.

Note 7: Luminance Uniformity is defined as follow:

Active area is divided into 9 measuring areas (Refer Fig. 2). Every measuring point is placed at the center of each measuring area.

$$\text{Uniformity (U)} = \frac{\text{Minimum Luminance( brightness ) in 9 points}}{\text{Maximum Luminance( brightness ) in 9 points}}$$

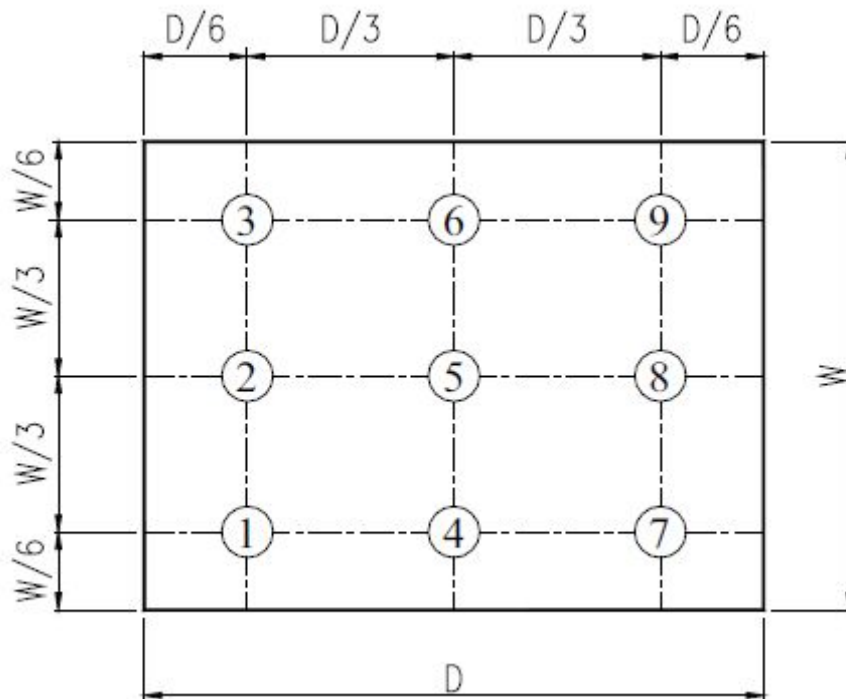

Fig. 2 Definition of uniformity

## 10. Environmental / Reliability Tests

No	Test Item	Condition	Judgment criteria
1	High Operation Temp	Ts=+70°C, 120hrs	Per table in below
2	Low Operation Temp	Ta=-20°C, 120hrs	Per table in below
3	High Temp Storage	Ta=+80°C, 120hrs	Per table in below
4	Low Temp Storage	Ta=-30°C, 120hrs	Per table in below
5	High Temp & High Humidity Storage	Ta=+40°C, 90% RH 120 hours	Per table in below (polarizer discoloration is excluded)
6	Thermal Shock (Non-operation)	-30°C 30 min~+80°C 30 min, Change time:5min, 10 Cycles	Per table in below
7	ESD (Operation)	C=150pF, R=330Ω 5points/panel Air:±8KV, 5times; Contact:±4KV, 5 times;	Per table in below
8	Vibration (Non-operation)	Frequency range:10~55Hz, Stroke:1.5mm Sweep:10Hz~55Hz~10Hz hours for each direction of X.Y.Z.	2 Per table in below
9	Shock (Non-operation)	60G 6ms, ±X,±Y,±Z 3times, for each direction	Per table in below
10	Package Drop Test	Height:80 cm, 1 corner, 3 edges, 6 surfaces	Per table in below

INSPECTION	CRITERION(after test)
Appearance	No Crack on the FPC, on the LCD Panel
Alignment of LCD Panel	No Bubbles in the LCD Panel No other Defects of Alignment in Active area
Electrical current	Within device specifications
Function / Display	No Broken Circuit, No Short Circuit or No Black line No Other Defects of Display

## 11. Precautions for Use of LCD Modules

### 11.1 Safety

The liquid crystal in the LCD is poisonous. Do not put it in your mouth. If the liquid crystal touches your skin or clothes, wash it off immediately using soap and water.

### 11.2 Handling

- A. The LCD and touch panel is made of plate glass. Do not subject the panel to mechanical shock or to excessive force on its surface.
- B. Do not handle the product by holding the flexible pattern portion in order to assure the reliability
- C. Transparency is an important factor for the touch panel. Please wear clear finger sacks, gloves and mask to protect the touch panel from finger print or stain and also hold the portion outside the view area when handling the touch panel.
- D. Provide a space so that the panel does not come into contact with other components.
- E. To protect the product from external force, put a covering lens (acrylic board or similar board) and keep an appropriate gap between them.
- F. Transparent electrodes may be disconnected if the panel is used under environmental conditions where dew condensation occurs.
- G. Property of semiconductor devices may be affected when they are exposed to light, possibly resulting in IC malfunctions.
- H. To prevent such IC malfunctions, your design and mounting layout shall be done in the way that the IC is not exposed to light in actual use.

### 11.3 Static Electricity

- A. Ground soldering iron tips, tools and testers when they are in operation.
- B. Ground your body when handling the products.
- C. Power on the LCD module before applying the voltage to the input terminals.
- D. Do not apply voltage which exceeds the absolute maximum rating.
- E. Store the products in an anti-electrostatic bag or container.

### 11.4 Storage

- A. Store the products in a dark place at  $+25^{\circ}\text{C} \pm 10^{\circ}\text{C}$  with low humidity (40% RH to 60% RH). Don't expose to sunlight or fluorescent light.
- B. Storage in a clean environment, free from dust, active gas, and solvent.

### 11.5 Cleaning

- A. Do not wipe the touch panel with dry cloth, as it may cause scratch.
- B. Wipe off the stain on the product by using soft cloth moistened with ethanol. Do not allow ethanol to get in between the upper film and the bottom glass. It may cause peeling issue or defective operation. Do not use any organic solvent or detergent other than ethanol.

### 11.6 Cautions for installing and assembling

Bezel edge must be positioned in the area between the Active area and View area. The bezel may press the touch screen and cause activation if the edge touches the active area. A gap of approximately 0.5mm is needed between the bezel and the top electrode. It may cause unexpected activation if the gap is too narrow. There is a tolerance of 0.2 to 0.3mm for the outside dimensions of the touch panel and tail. A gap must be made to absorb the tolerance in the case and connector.

