

**DLC Display Co., Limited**

德爾西顯示器有限公司



MODEL No: DLC0500KZG

TEL: 86-755-86029824

FAX: 86-755-86029827

E-MAIL: [sales@dlcdisplay.com](mailto:sales@dlcdisplay.com)

WEB: [www.dlcdisplay.com](http://www.dlcdisplay.com)

### Record of Revision

Date	Revision No.	Summary
2014 05 15	1.0	Rev 1.0 was issued

### 1. Scope

This data sheet is to introduce the specification of DLC0500KZG active matrix TFT module. It is composed of a color TFT-LCD panel, driver ICs, FPC and a backlight unit. The 5.0" display area contains 480(RGB) x 854 pixels.

### 2. Application

Digital equipments which need color display, mobile phone, mobile navigator/video systems.

### 3. General Information

Item	Contents	Unit
Size	5.0	inch
Resolution	480 (RGB) x 854	/
Interface	MIPI VIDEO MODE	/
Technology type	a-Si TFT	/
Pixel Configuration	RGB stripes	
Outline Dimension (W x H x D)	65.30x118.8x1.6	mm
Active Area	61.56 x 109.53	mm
Display Mode	Transmissive Normally white	/
Backlight Type	LED	/
Driver IC	ILI9806E	/

### 4. Outline Drawing

PN	NAME	PN	NAME
1	VBAT	21	MPI_D0P
2	KEYPAD_LED	22	MPI_D0N
3	VIBR	23	GND
4	GND	24	MPI_D1P
5	MIC	25	MPI_D1N
6	MIC	26	GND
7	GND	27	GND
8	SPK	28	VDD_2.8V
9	SPK	29	VDD_1.8V
10	GND	30	GND
11	KCOL_1	31	MPI_D0P
12	KROW_0	32	MPI_D0N
13	LCD_I0	33	GND
14	LPTE	34	NC
15	RESET	35	NC
16	NC	36	NC
17	GND	37	LED-K
18	MPI_CLKP	38	LED-A
19	MPI_CLKN	39	GND
20	GND		

BL 509-08G31  
(接小板)

PN	NAME
1	KEYPAD_LED
2	KEYPAD_LED
3	KEYPAD_LED
4	KEYPAD_LED
5	KEYPAD_LED
6	KEYPAD_LED
7	KEYPAD_LED
8	KEYPAD_LED

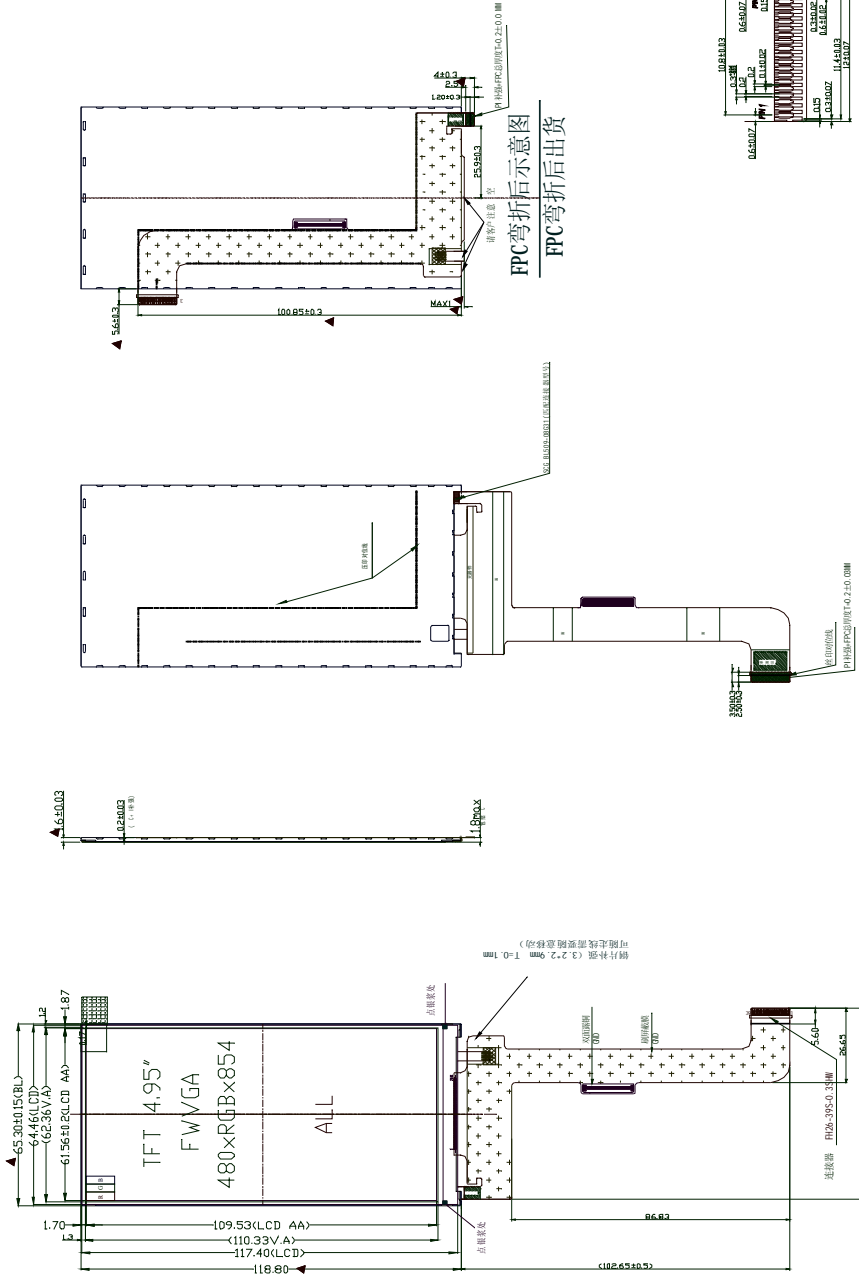

**FPC弯折后示意图**  
FPC弯折后出货

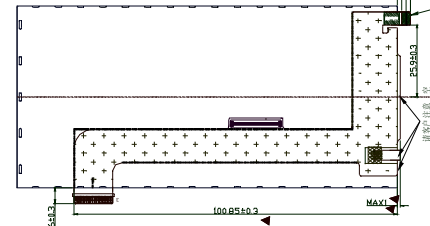
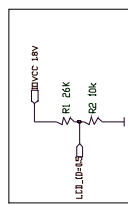
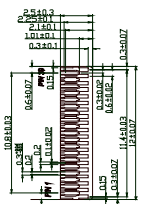
SCALE: 4:1  
FR26-395-0\_35HW

▲ 重点测量尺寸

**NOTE:**  
 1 DISPLAY TYPE : 4.95" FWGA TFT  
 2 VIEWING DIRECTION : ALL  
 3 LCD DRIVER : ILI9806E  
 4 OPERATING TEMP : -20° C--+70° C  
 5 STORAGE TEMP : -30° C--+80° C  
 6 UNSPECIFIED TOLERANCE ±0.2

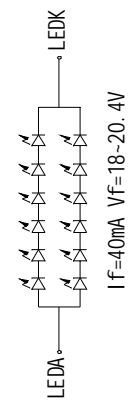

I<sub>f</sub>=40mA V<sub>f</sub>=18-20.4V

DLC Display Co., Limited

www.dlcdisplay.com

DRAWN BY:	TITLE: DLC0500KZG	SCALE:
CHECKED BY:	DWG NO:	UNIT: mm
APPROVED BY:	DWG NAME:	SHEET NO: 0F
CONFIRMED BY:		

**5. Interface signals**

NO.	SYMBOL	DISCRIPTION	I/O
1	VTAT	Phone motherboard connection	
2	KEYPAD_LED-	Phone motherboard connection	
3	VIBR+	Phone motherboard connection	
4	GND	Ground.	P
5	MIC+	Phone motherboard connection	
6	MIC-	Phone motherboard connection	
7	GND	Ground.	P
8	SPK+	Phone motherboard connection	
9	SPK-	Phone motherboard connection	
10	GND	Ground.	P
11	NC	-	
12	NC	-	
13	LCM_ID	LCM_ID=1.2V	O
14	TE	Tearing effect output. Be used after writing data to RAM	O
15	RESET	SYSTEM RESET	I
16	NC	-	
17	GND	Ground.	P
18	MIPI_CLKP	MIPI-DSI Clock differential signal input pins.	I
19	MIPI_CLKN		
20	GND	Ground.	P
21	MIPI_D0P	MIPI-DSI Data0 differential signal input pins.	I/O
22	MIPI_D0N		
23	GND	Ground	P

24	MIPI_D1P	MIPI-DSI Data1 differential signal input pins.	I
25	MIPI_D1N		
26	GND	Ground	P
27	GND	Ground	P
28	VCC	TYP: 2.8 V	P
29	IOVCC	TYP: 1.8 V	P
30-36	NC	-	
37	LEDK	Cathode pin OF backlight	P
38	LEDA	Anode pin of backlight	P
39	GND	Ground	P

## 6. Absolute maximum Ratings

### 6.1. Electrical Absolute max. ratings

Parameter	Symbol	MIN	MAX	Unit	Remark
Logic Supply Voltage	VCC	-0.3	4.6	V	
Power voltage for LCD	IOVCC	-0.3	4.0	V	
Input voltage for logic	VIN	-0.3	IOVCC +0.3	V	

### 6.2. Environment Conditions

Item	Symbol	MIN	MAX	Unit	Remark
Operating Temperature	TOPR	-20	70	°C	
Storage Temperature	TSTG	-30	80	°C	

## 7. Electrical Specifications

### 7.1 Electrical characteristics

GND=0V, Ta=25°C

Item	Symbol	MIN	TYP	MAX	Unit	Remark
Logic Supply Voltage	VCC	--	2.8	--	V	
Power voltage for LCD	IOVCC	--	1.8	--	V	

### 7.2 LED Backlight

Ta=25°C

Item	Symbol	MIN	TYP	MAX	Unit	Remark
Forward Current	IF	-	40	-	mA	
Forward Voltage	VF	18	-	20.4	V	

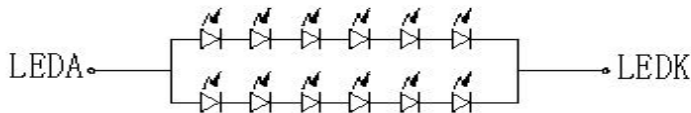

### 7.3 BLOCK DIAGRAM

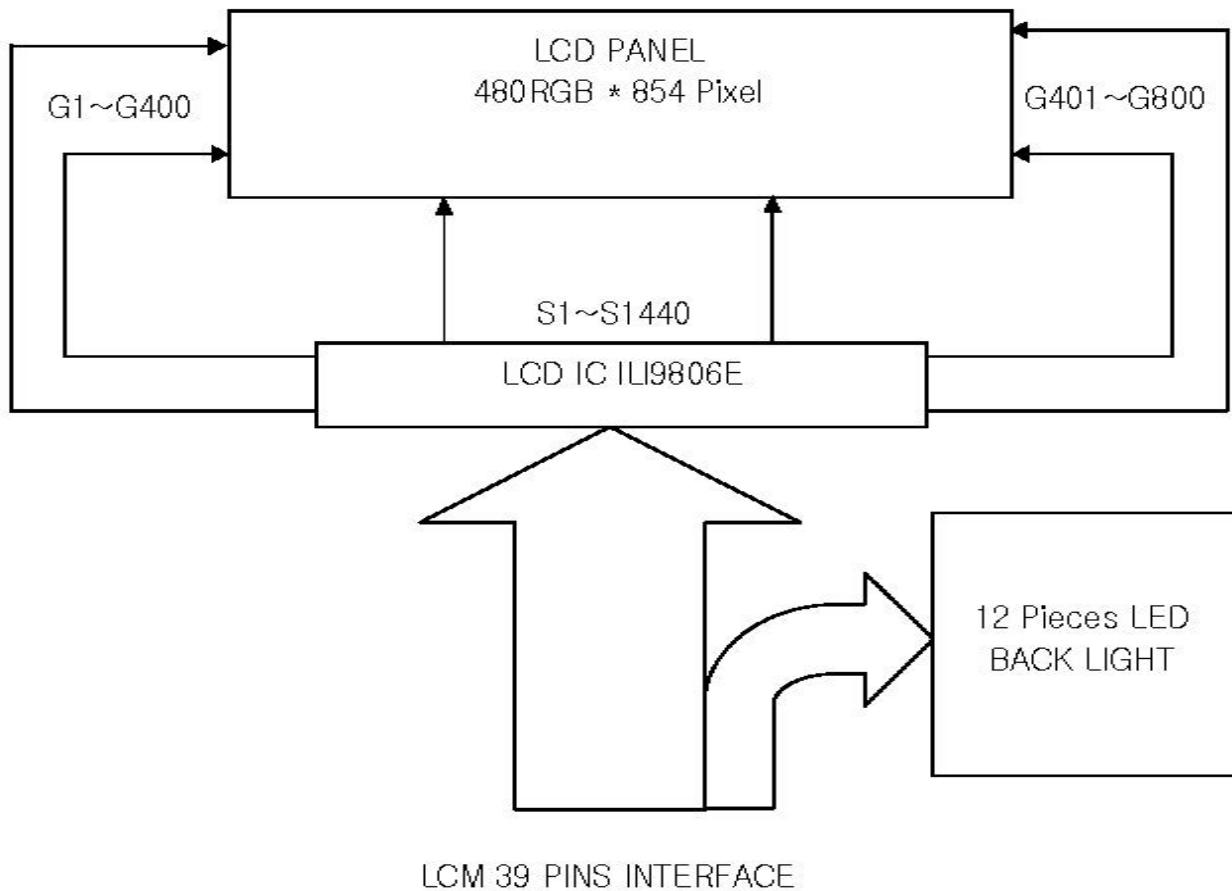

## 8. Optical Specification

Ta=25°C

Item	Symbol	Condition	Min	Typ.	Max.	Unit	Remark
Contrast Ratio	CR	$\theta=0^\circ$		800			Note1 Note2
Response Time	Ton/ Toff	25°C		30		ms	Note1 Note3
View Angles	$\theta T$	$CR \geq 10$		70		Degree	Note 4
	$\theta B$			60			
	$\theta L$			70			
	$\theta R$			70			
Luminance	L		280			cd/m <sup>2</sup>	Note1 Note5
Uniformity	U		--	75	--	%	Note1 Note6

Note 1: Definition of optical measurement system.

Temperature = 25°C(±3°C)

LED back-light: ON, Environment brightness < 150 lx

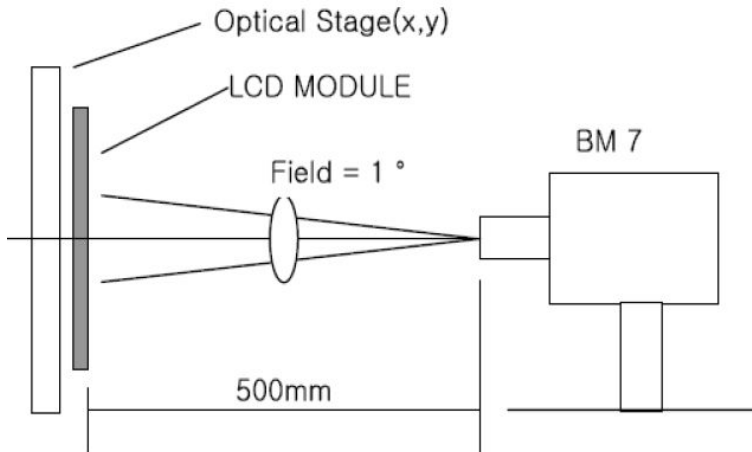

Note 2: Contrast ratio is defined as follow:

$$\text{Contrast Ratio} = \frac{\text{Surface Luminance with all white pixels}}{\text{Surface Luminance with all black pixels}}$$



Note 3: Response time is defined as follow:

Response time is the time required for the display to transition from black to white (Rise Time,  $T_r$ ) and from white to black(Decay Time,  $T_f$ ).

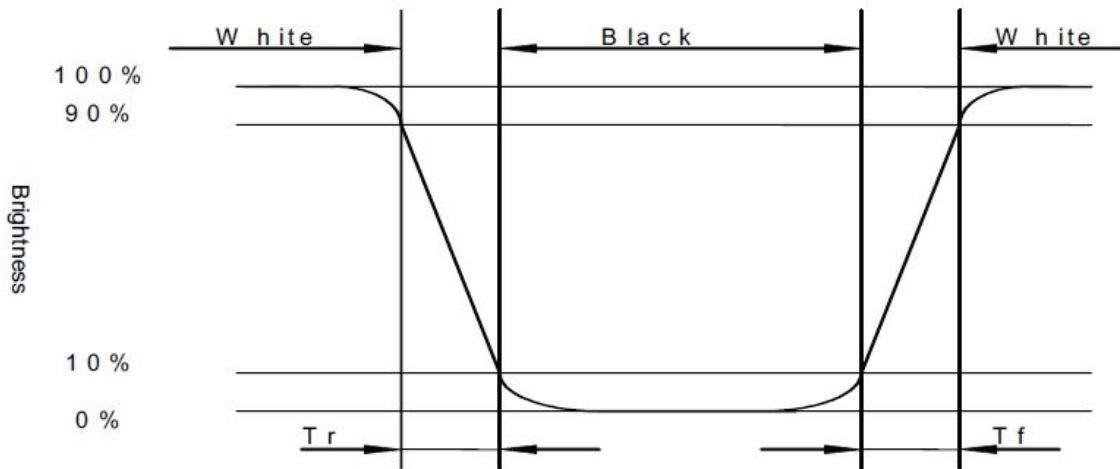

Note 4: Viewing angle range is defined as follow:

Viewing angle is measured at the center point of the LCD.

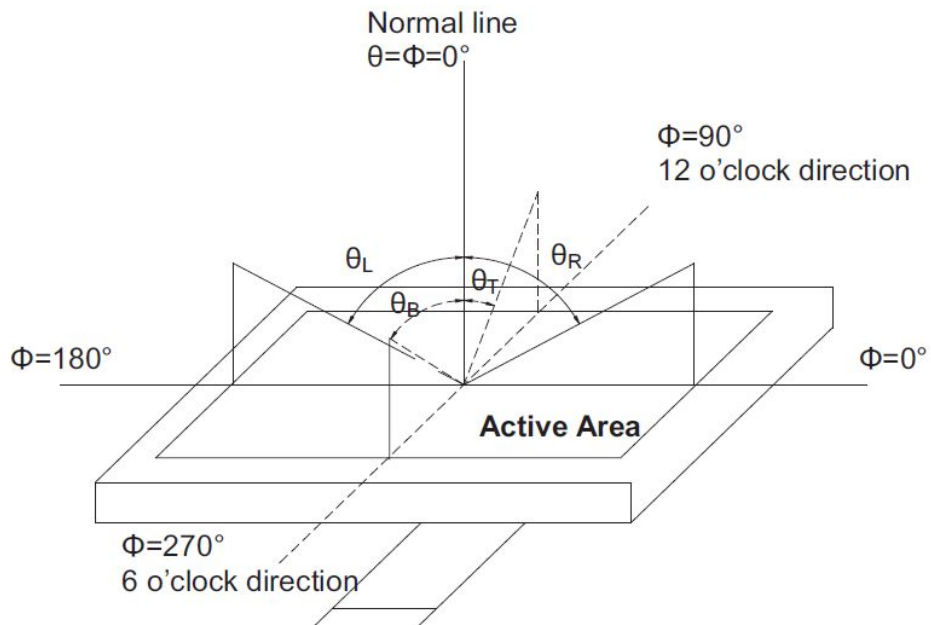

Note 5: Luminance is defined as follow:

Luminance is defined as the brightness of all pixels “White” at the center of display area on optimum contrast.

Note 6: Luminance Uniformity is defined as follow:

Active area is divided into 9 measuring areas (Refer Fig. 2). Every measuring point is placed at the center of each measuring area.

$$\text{Uniformity (U)} = \frac{\text{Minimum Luminance( brightness ) in 9 points}}{\text{Maximum Luminance( brightness ) in 9 points}}$$

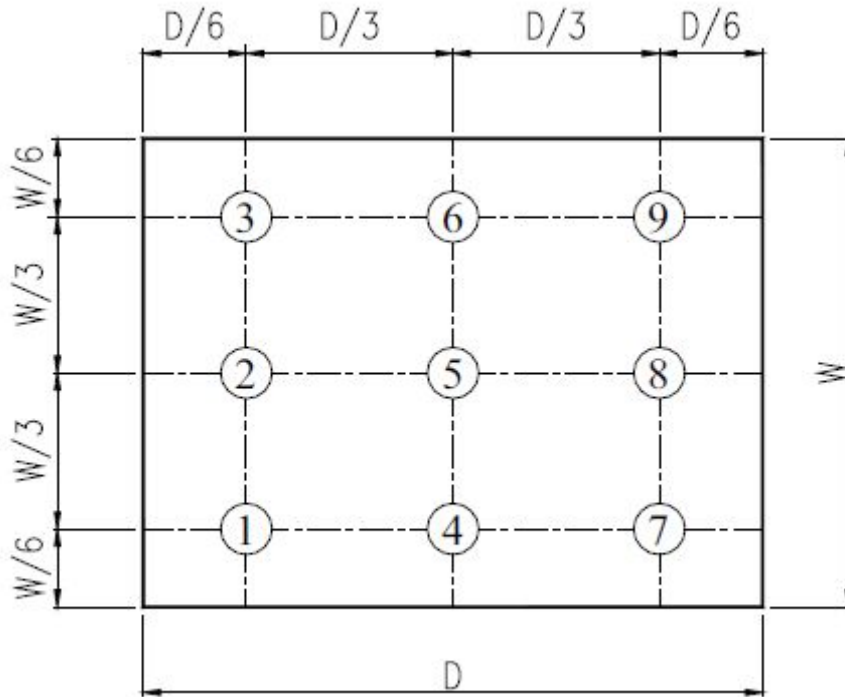

Fig. 2 Definition of uniformity

## 9. Environmental / Reliability Tests

No	Test Item	Condition	Judgment criteria
1	High Temp Operation	Ts=+70°C, 120hrs	Per table in below
2	Low Temp Operation	Ta= 20°C, 120hrs	Per table in below
3	High Temp Storage	Ta=+80°C, 120hrs	Per table in below
4	Low Temp Storage	Ta= 30°C, 120hrs	Per table in below
5	High Temp & High Humidity Storage	Ta=+40°C, 90% RH 120 hours	Per table in below (polarizer discoloration is excluded)
6	Thermal Shock (Non operation)	30°C 30 min~+80°C 30 min, Change time:5min, 10 Cycles	Per table in below
7	ESD (Operation)	C=150pF, R=330Ω , 5points/panel Air:±8KV, 5times; Contact:±4KV, 5 times;	Per table in below
8	Vibration (Non operation)	Frequency range:10~55Hz, Stroke:1.5mm Sweep:10Hz~55Hz~10Hz 2 hours for each direction of X.Y.Z.	Per table in below
9	Shock (Non operation)	60G 6ms, ±X,±Y,±Z 3times, for each direction	Per table in below
10	Package Drop Test	Height:80 cm, 1 corner, 3 edges, 6 surfaces	Per table in below

INSPECTION	CRITERION(after test)
Appearance	No Crack on the FPC, on the LCD Panel
Alignment of LCD Panel	No Bubbles in the LCD Panel No other Defects of Alignment in Active area
Electrical current	Within device specifications
Function / Display	No Broken Circuit, No Short Circuit or No Black line No Other Defects of Display

## 10. Precautions for Use of LCD Modules

### 10.1 Safety

The liquid crystal in the LCD is poisonous. Do not put it in your mouth. If the liquid crystal touches your skin or clothes, wash it off immediately using soap and water.

### 10.2 Handling

- A. The LCD and touch panel is made of plate glass. Do not subject the panel to mechanical shock or to excessive force on its surface.
- B. Do not handle the product by holding the flexible pattern portion in order to assure the reliability
- C. Transparency is an important factor for the touch panel. Please wear clear finger sacks, gloves and mask to protect the touch panel from finger print or stain and also hold the portion outside the view area when handling the touch panel.
- D. Provide a space so that the panel does not come into contact with other components.
- E. To protect the product from external force, put a covering lens (acrylic board or similar board) and keep an appropriate gap between them.
- F. Transparent electrodes may be disconnected if the panel is used under environmental conditions where dew condensation occurs.
- G. Property of semiconductor devices may be affected when they are exposed to light, possibly resulting in IC malfunctions.
- H. To prevent such IC malfunctions, your design and mounting layout shall be done in the way that the IC is not exposed to light in actual use.

### 10.3 Static Electricity

- A. Ground soldering iron tips, tools and testers when they are in operation.
- B. Ground your body when handling the products.
- C. Power on the LCD module before applying the voltage to the input terminals.
- D. Do not apply voltage which exceeds the absolute maximum rating.
- E. Store the products in an anti-electrostatic bag or container.

### 10.4 Storage

- A. Store the products in a dark place at  $+25^{\circ}\text{C} \pm 10^{\circ}\text{C}$  with low humidity (40% RH to 60% RH). Don't expose to sunlight or fluorescent light.
- B. Storage in a clean environment, free from dust, active gas, and solvent.

### 10.5 Cleaning

- A. Do not wipe the touch panel with dry cloth, as it may cause scratch.
- B. Wipe off the stain on the product by using soft cloth moistened with ethanol. Do not allow ethanol to get in between the upper film and the bottom glass. It may cause peeling issue or defective operation. Do not use any organic solvent or detergent other than ethanol.

### 10.6 Cautions for installing and assembling

Bezel edge must be positioned in the area between the Active area and View area. The bezel may press the touch screen and cause activation if the edge touches the active area. A gap of approximately 0.5mm is needed between the bezel and the top electrode. It may cause unexpected activation if the gap is too narrow. There is a tolerance of 0.2 to 0.3mm for the outside dimensions of the touch panel and tail. A gap must be made to absorb the tolerance in the case and connector.

