

DLC Display Co., Limited

德爾西顯示器有限公司



MODEL No:DLC1210BBG

TEL: 86-755-86029824

FAX: 86-755-86029827

E-MAIL: sales@dlcdisplay.com

WEB: www.dlcdisplay.com



Record of Revision

Date	Revision No.	Summary
2014-07-10	1.0	Rev 1.0 was issued

1. Scope

This data sheet is to introduce the specification of DLC1210BBG active matrix TFT module. It is composed of a color TFT-LCD panel, driver ICs, FPC and a backlight unit. The 12.1" display area contains 800(RGB) x600 pixels.

2. Application

Digital equipments which need color display, such as P.O.S, medical equipments and industrial equipments.

3. General Information

Item	Contents	Unit
Size	12.1	inch
Resolution	800(RGB)x600	/
Interface	LVDS	/
Technology type	a-Si TFT	/
Pixel pitch	0.3075x0.3075	mm
Pixel Configuration	R.G.B. Vertical Stripe	
Outline Dimension (W x H x D)	279.00x209.00x9.0	mm
Active Area	246.00x184.50	mm
Display Mode	Transmissive, Normally white	/
Backlight Type	LED	/

4. Outline Drawing

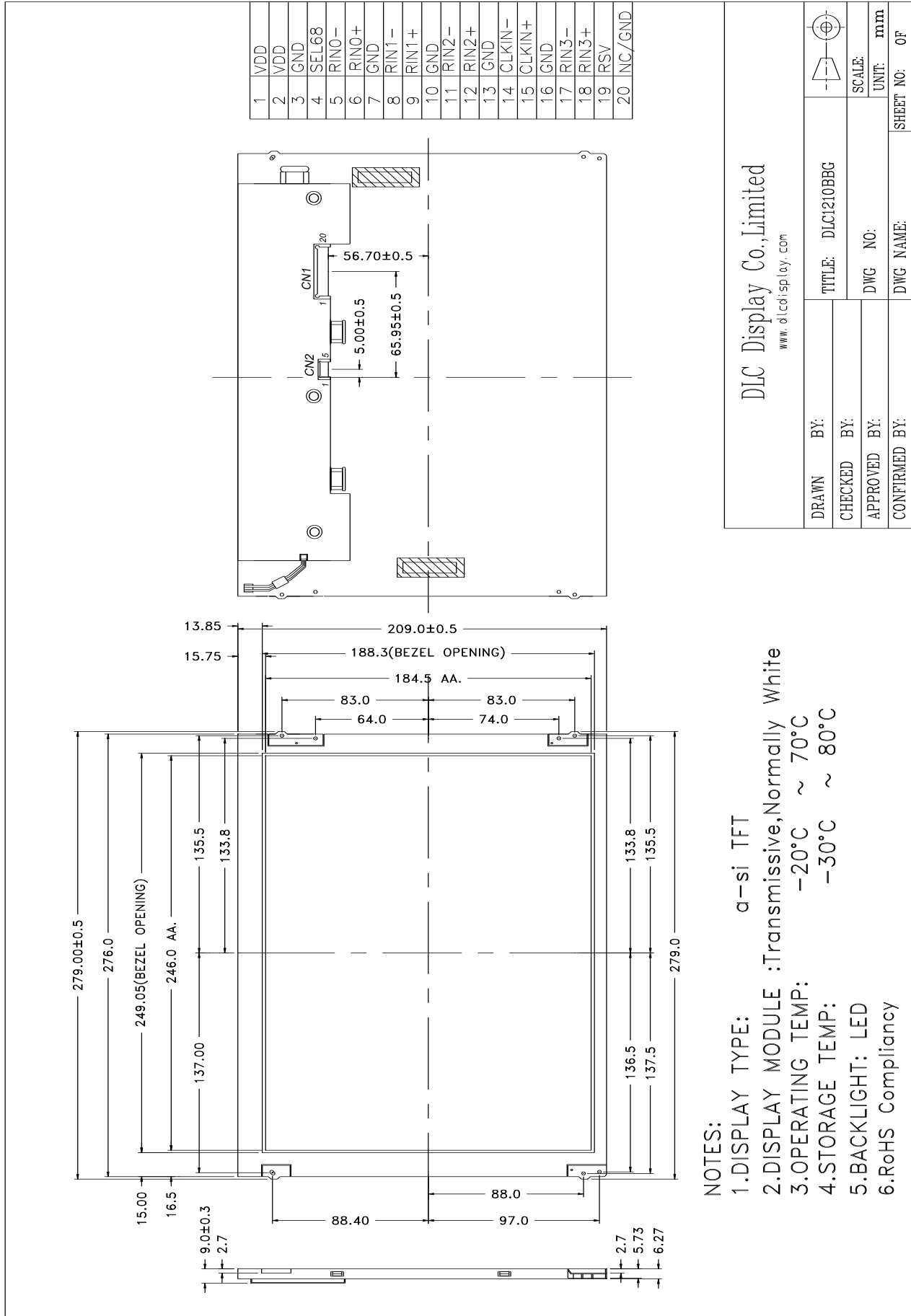

DLC Display Co., Limited
www.dlcdisplay.com

DRAWN BY:	TITLE: DLC1210BBG	
CHECKED BY:	DWG NO:	SCALE:
APPROVED BY:	DWG NAME:	UNIT: mm
CONFIRMED BY:	SHEET NO:	OF

- NOTES:
- 1.DISPLAY TYPE: a-si TFT
 - 2.DISPLAY MODULE :Transmissive,Normally White
 - 3.OPERATING TEMP: -20°C ~ 70°C
 - 4.STORAGE TEMP: -30°C ~ 80°C
 - 5.BACKLIGHT: LED
 - 6.RoHS Compliance

5. Interface signals

Pin	Name	Description
1	VDD	3.3V Power Supply
2	VDD	3.3V Power Supply
3	GND	Ground
4	SEL68	Select 6 or 8 Bits LVDS Input H:8Bits ; L/NC: 6Bits
5	RIN0-	LVDS receiver signal channel 0,
6	RIN0+	LVDS differential data input(R0,R1,R2,R3,R4,R5,G0)
7	GND	Ground
8	RIN1-	LVDS receiver signal channel 1,
9	RIN1+	LVDS differential data input(G1,G2,G3,G4,G5,B0,B1)
10	GND	Ground
11	RIN2-	LVDS receiver signal channel 2,
12	RIN2+	LVDS differential data input(B2,B3,B4,B5,HS,VS,DE)
13	GND	Ground
14	CLKIN-	LVDS receiver Signal Clock
15	CLKIN+	
16	GND	Ground
17	RIN3-	LVDS receiver signal channel 3, NC for 6Bits LVDS input
18	RIN3+	LVDS differential data input(R6,R7,G6,G7,B6,B7,RSV)
19	RSV	Reverse Scan Function H: Display Reverse; L/NC: Normal Display
20	NC/GND	Test Function Pin Please treat it as NC

Connector: MSB240420-E

LED backlight:

Pin	Name	Description
1	VCC	12V
2	GND	GND
3	On/Off	5V-On / 0V-Off
4	Dimming	PWM Dimming or Analog Dimming
5	NC	NC

Connector: 3808K-F03N-02R

6. Absolute maximum Ratings

6.1. Electrical Absolute max. ratings

The absolute maximum ratings are list on table as follows. When used out of the absolute maximum ratings, the LSI may be permanently damaged. Using the LSI within the following electrical characteristics limit is strongly recommended for normal operation. If these electrical characteristic conditions are exceeded during normal operation, the LSI will malfunction and cause poor reliability.

Source IC--- HX8245-C

Parameter	Symbol	MAX	Unit
Power Supply Voltage	AVDD	14.85	V
Driver supply voltage	VDD	3.96	V
Input voltage	Vr1~Vr18	AVDD+0.3	V
	Others	0.6VDD	V

Gate IC--- HX8677-G

Parameter	Symbol	MAX	Unit
Power Supply Voltage1	VDD	7.0	V
Power supply voltage2	VGH	42	V
Power supply voltage3	VGH-42	VGH-42	V
Power supply voltage4	VGH-VGL	42	V

Tcon IC---HX8841

Parameter	Symbol	MAX	Unit
Supply Voltage	VDD	3.6	V
CMOS/TTL input voltage	Vin	3.6	V
CMOS/TTL output voltage	Vout	3.6	V
LVDS receiver input voltage	Vin	3.6	V

6.2. Environment Conditions

Item	Symbol	MIN	MAX	Unit	Remark
Operating Temperature	TOPR	-20	70	°C	
Storage Temperature	TSTG	-30	80	°C	

7. Electrical Specifications

7.1 Electrical characteristics

Source IC--- HX8245-C

(For the analog circuit)

Parameter	Symbol	Spec.			Unit	Conditions
		Min.	Typ.	Max.		
Supply Voltage	AVDD	6.5	8.4	13.5	V	For the analog circuit power
Input Level of $V_{\gamma 1} \sim V_{\gamma 7}$	V_{REF}	0.4AVDD	-	AVDD-0.1	V	Gamma correction voltage
Input Level of $V_{\gamma 8} \sim V_{\gamma 14}$	V_{REF}	0.1	-	0.6AVDD	V	Gamma correction voltage
Output Voltage Deviation	V_{OD}	-	-	± 20	mV	-
Voltage Output Offset between Chips	V_{OC}	-	-	± 15	mV	-
Dynamic Range of Output	V_{DR}	0.1	-	AVDD-0.1	V	OUT1~OUT1200/1026
Sinking Current of Outputs	I_{OL}	-	-80	-	μA	OUT1~OUT1200/1026; AVDD=10V $V_o=0.1V$ v.s 1.0V
Driving Current of Outputs	I_{OH}	-	80	-	μA	OUT1~OUT1200/1026; AVDD=10V $V_o=9.9V$ v.s 9.0V
Impedance of Gamma Correction	R_i	0.8Rn	1.1Rn	1.4Rn	Ω	Rn: Internal gamma resistor
Analog Stand-by Current	I_{sc}	-	3.7	-	mA	No load, AVDD=8.4V and all operating is stopped
Analog Operating Current	I_{oc}	-	19	-	mA	$F_{CLK}=40MHz$ $F_{LD}=50KHz$ AVDD=8.4V $V_{\gamma 1}=8V$ $V_{\gamma 14}=0.4V$ in black pattern

Gate IC--- HX8677-G

Parameter	Symbol	Applicable pin	Condition	Spec.			Unit
				Min.	Typ.	Max.	
Input H voltage	V_{IH}	All input pins	-	0.7VDD	-	VDD	V
Input L voltage	V_{IL}	All input pins	-	VSS	-	0.3VDD	
Output H voltage	V_{OH}	STV1,2	$I_{OH}=40\mu A$	VDD-0.4	-	VDD	
Output L voltage	V_{OL}	STV1,2	$I_{OL}=40\mu A$	VSS	-	VSS+0.4	
Output H resistance	R_{OH}	OUT1 ~ OUT600	$V_{OUT}=$ VGH-0.5V	-	-	1000	Ω
Output L resistance	R_{OL}	OUT1 ~ OUT600	$V_{OUT}=$ VGL+0.5V	-	-	1000	Ω
Input leakage current	I_{IN}	Note ⁽¹⁾	-	-1.0	-	+1.0	μA
Pull high resistance1	R_{PU}	/XAO	$V_{IN}=VSS$	40	-	200	k Ω
Pull high resistance2	R_{PU}	Note ⁽²⁾	VDD=3.3V, $T_A=25^\circ C$	70	200	400	k Ω
Pull low resistance	R_{PD}	Note ⁽³⁾	VDD=3.3V, $T_A=25^\circ C$	70	200	400	k Ω
Power off reset threshold voltage	V_{POFF}	-	-	-	1.6	-	V
VGH Power consumption	I_{VGH}	VGH	Note ⁽⁴⁾	-	-	200	μA
VDD Power consumption	I_{VDD}	VDD		-	-	100	

Note: (1) All input except /XAO, MODE1, MODE2, SEG1, SEG2, EVEN.

(2) MODE1, MODE2.

(3) SEG1, SEG2, EVEN.

(4) Power consumption in the following condition.

Output no load, VGH=20V, VGL=-8V, VDD=3.0V, $V_{IH}=VDD$, $V_{IL}=VSS$, $F_{CPV}=50KHz$,
SEG1=SEG2=EVEN=OE1=OE2=OE3= V_{IL} , MODE1=MODE2=/XAO= V_{IH} .

Tcon IC---HX8841

For VDD33 = 3.3 V operation

Symbol	Parameter	Conditions	Min.	Typ.	Max.	Unit
I_{DD}	Supply Current	F=54MHz, VDD33=3.3V, PI=13K Ω ,RL=100 Ω pixel checker pattern	-	75	-	mA
CMOS/TTL DC SPECIFICATIONS						
V_{IH}	High Level Input Voltage	-	0.7VDD 33	-	VDD33	V
V_{IL}	Low Level Input Voltage	-	VSS	-	0.3VD D33	V
V_{OH}	High Level Output Voltage	-	0.8 VDD33	-	VDD33	V
V_{OL}	Low Level Output Voltage	-	VSS	-	0.2 VDD33	V
I_{IN}	Input Current	-	-10	-	10	μ A
LVDS DC SPECIFICATIONS						
V_{TH}	Differential Input High Threshold	Vlvcm=1.2V	-	-	+100	mV
V_{TL}	Differential Input Low Threshold		-100	-	-	mV
V_{IC}	LVDS Common mode voltage	-	0.7	-	1.6	V
V_{ID}	LVDS swing voltage	-	\pm 100	-	\pm 600	mV
I_{IN}	Input Current	$V_{IN}=+2.4V/0V$	-	-	10	μ A
RSDS DC SPECIFICATIONS						
V_{od}	Output differential voltage	RL=100 Ω PI=13K Ω (Temp=25 $^{\circ}$ C)	-	TBD	-	mV
V_{os}	Output offset voltage		1.0	1.2	1.4	V
I_{os}	Output current	output shorted to GND	-	-3.5	-5.0	mA

7.2 LED Backlight

 Ta=25 $^{\circ}$ C

Item	Symbol	MIN	TYP	MAX	Unit	Remark
Forward Current	IF	-	80	-	mA	
Forward Voltage	VF	-	27	28.2	V	
LED Life Time			50000	--	hrs	IF=80mA Note 1

Notes:

1. The LED Life-time define as the estimated time to 50% degradation of initial luminous.

7.3 Power Consumption

Item	Symbol	MIN	TYP	MAX	Unit	Remark
Normal mode	I_{VDDI+} I_{VCI}	-	6.7	-	W	Note

Note:

 Frame rate=60HZ, Typ. Pattern White pattern, worst case pattern 1x1 checker 25 $^{\circ}$ C.

8. Command/AC Timing

8.1 TIMING CHARACTERISTICS

Ideal strobe position for LVDS input

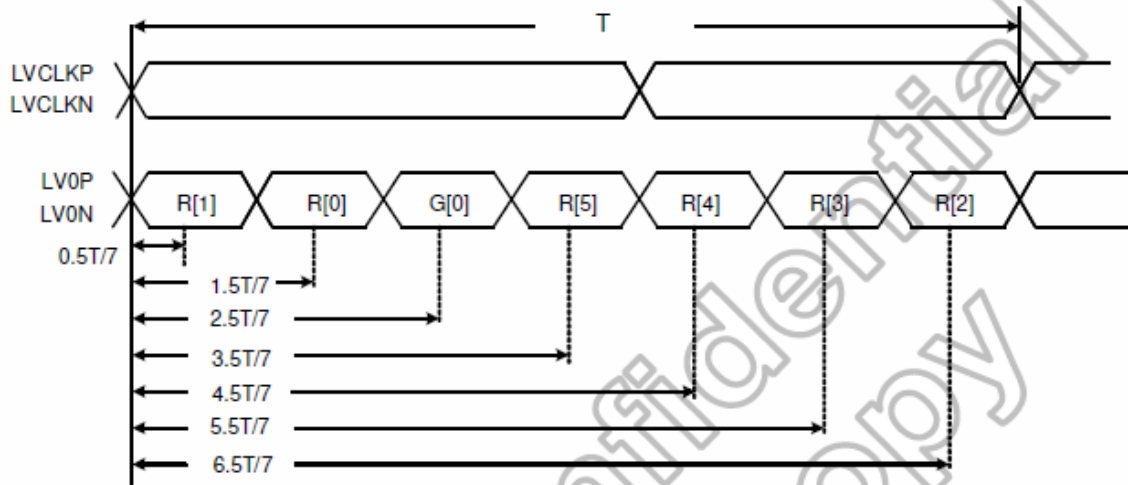

Figure 6.1: LVDS input data ideal strobe position

LVDS input data mapping

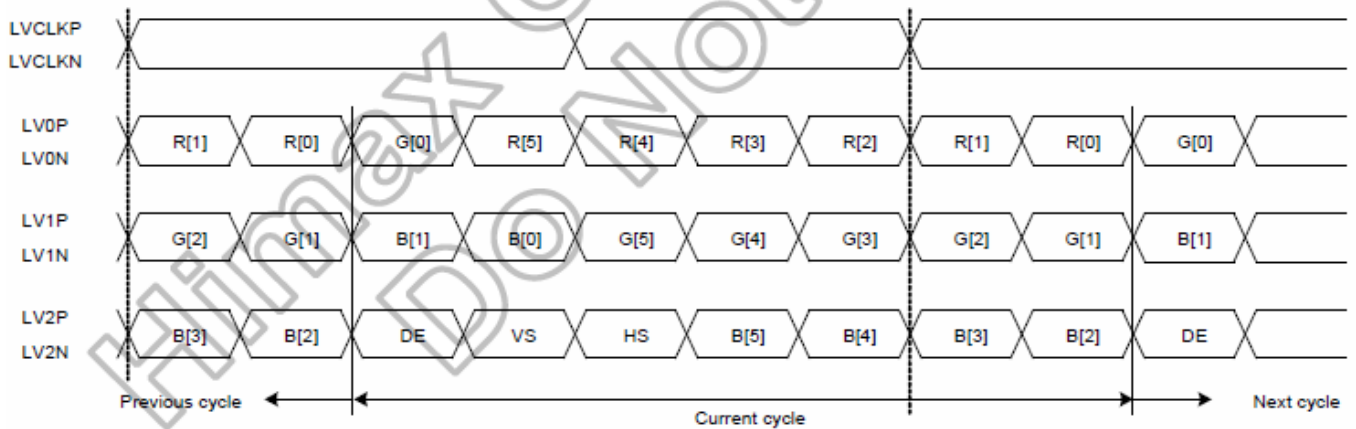

Figure 6.2: LVDS input data mapping

8.2 POWER ON SEQUENCE

Power up sequence

Figure 0.3: Power up sequence

Symbol	Parameter	Condition	Spec.			Unit
			Min.	Typ.	Max.	
V_{TH}	Reset threshold voltage	-	2	2.1	2.2	V
V_{HYS}	Hysteresis voltage	-	-	200	-	mV
T_{RST}	Reset duration @R=10K Ω , C=1 μ F	-	10	-	-	ms

9. Optical Specification

Ta=25°C

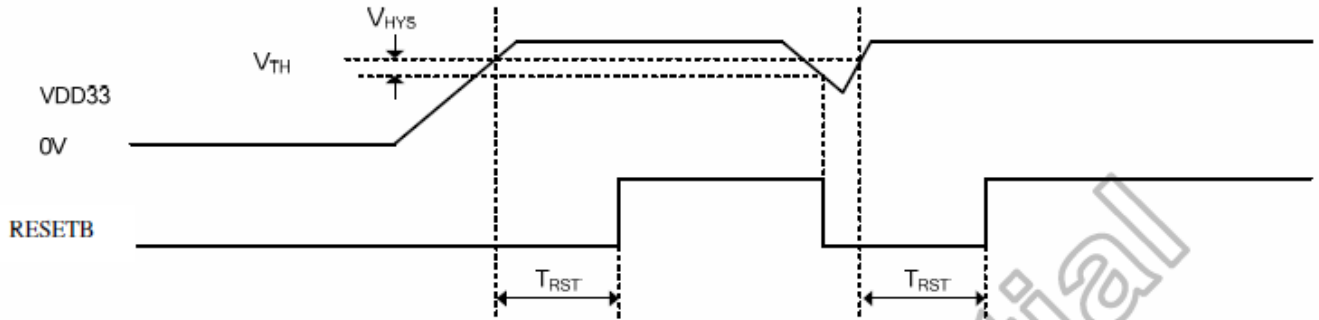
Item	Symbol	Condition	Min	Typ.	Max.	Unit	Remark
Contrast Ratio	CR	$\theta=0^\circ$	600	800	-		Note1 Note2
Response Time	Ton/ Toff	25°C	-	30	-	ms	Note1 Note3
View Angles	θT	$CR \geq 10$	55	65	-	Degree	Note 4
	θB		65	75	-		
	θL		70	80	-		
	θR		70	80	-		
Chromaticity	W	Brightness is on	X	0.313	-	Note5, Note1	
			Y	0.329	-		
	R		X	TBD	-		
			Y	TBD	-		
	G		X	TBD	-		
			Y	TBD	-		
	B		X	TBD	-		
			Y	TBD	-		
NTSC	S		-	55	-	%	Note 5
Luminance	L		300	400	-	cd/m ²	Note1 Note6
Uniformity	U		75	80	-	%	Note1 Note7
NTSC				55		%	

Note 1: Definition of optical measurement system.

Temperature = 25°C (±3°C)

LED back-light: ON, Environment brightness < 150 lx

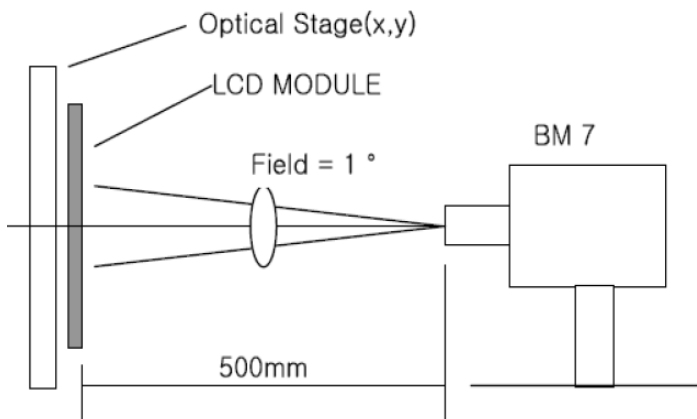

Note 2: Contrast ratio is defined as follow:

$$\text{Contrast Ratio} = \frac{\text{Surface Luminance with all white pixels}}{\text{Surface Luminance with all black pixels}}$$

Note 3: Response time is defined as follow:

Response time is the time required for the display to transition from black to white (Rise Time, T_r) and from white to black (Decay Time, T_f).

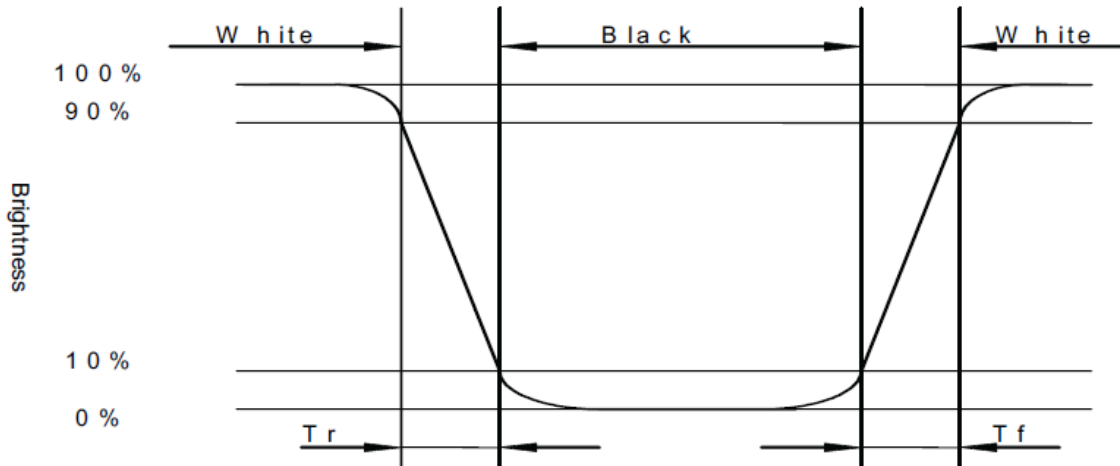

Note 4: Viewing angle range is defined as follow:

Viewing angle is measured at the center point of the LCD.

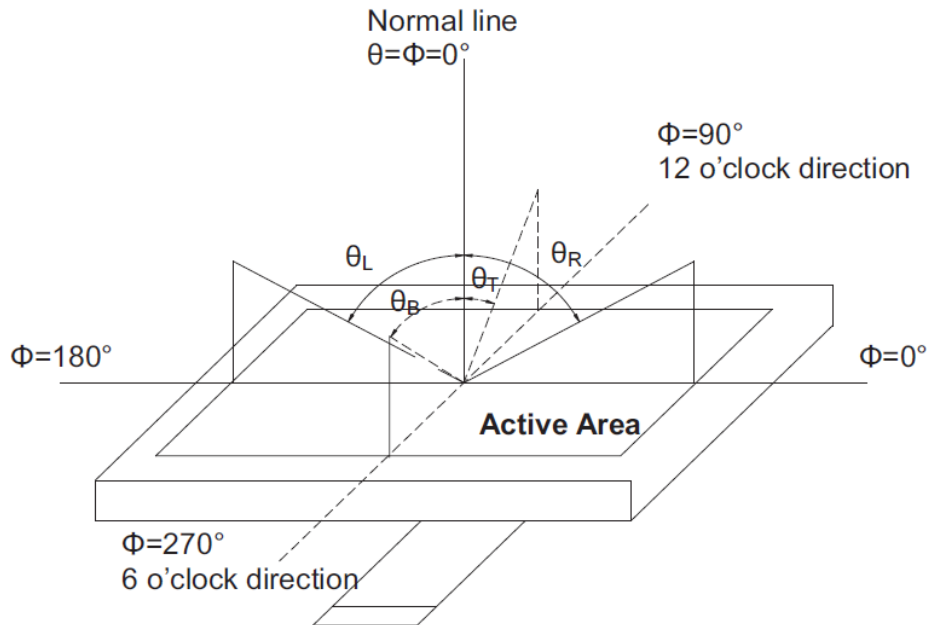

Note 5: Color chromaticity is defined as follow: (CIE1931)

Color coordinates measured at center point of LCD.

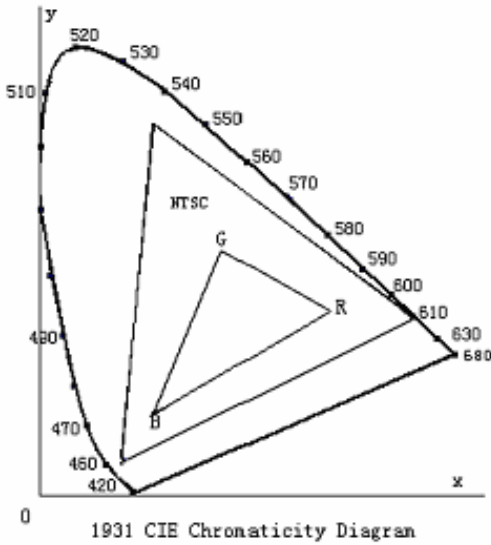

$$S = \frac{\text{area of RGB triangle}}{\text{area of NTSC triangle}} \times 100\%$$

Note 6: Luminance is defined as follow:

Luminance is defined as the brightness of all pixels “White” at the center of display area on optimum contrast.

Note 7: Luminance Uniformity is defined as follow:

Active area is divided into 9 measuring areas (Refer Fig. 2). Every measuring point is placed at the center of each measuring area.

$$\text{Uniformity (U)} = \frac{\text{Minimum Luminance (brightness) in 9 points}}{\text{Maximum Luminance (brightness) in 9 points}}$$

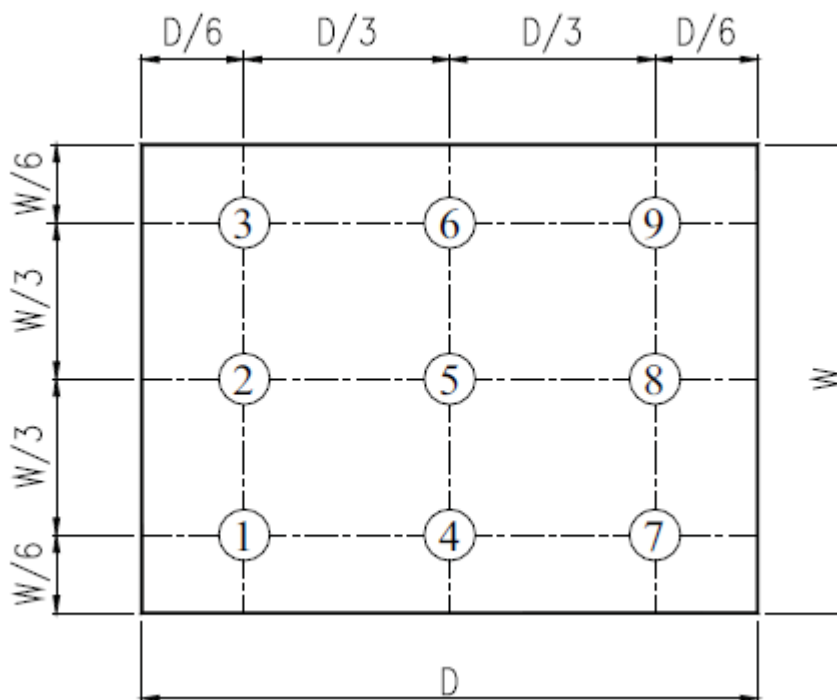

Fig. 2 Definition of uniformity

10. Environmental / Reliability Tests

No	Test Item	Condition	Judgment criteria
1	High Temp Operation	Ts=+80°C, 96hrs	Per table in below
2	Low Temp Operation	Ta=-30°C, 96hrs	Per table in below
3	High Temp Storage	Ta=+70°C, 48hrs	Per table in below
4	Low Temp Storage	Ta=-20°C, 48hrs	Per table in below
5	High Temp & High Humidity Storage	Ta=+40°C, 90% RH 48 hours	Per table in below (polarizer discoloration is excluded)
6	Thermal Shock (Non-operation)	-30°C 30 min~+80°C 30 min, Change time:5min, 10 Cycles	Per table in below
7	ESD (Operation)	C=150pF, R=330Ω , 5points/panel Air:±8KV, 5times; Contact:±4KV, 5 times;	Per table in below
8	Vibration (Non-operation)	10Hz~150Hz, 100m/s ² , 120min	Per table in below
9	Shock (Non-operation)	Half- sine wave, 300m/s ² , 18ms	Per table in below
10	Package Drop Test	25kPa 16H Restore 2H	Per table in below

INSPECTION	CRITERION(after test)
Appearance	No Crack on the FPC, on the LCD Panel
Alignment of LCD Panel	No Bubbles in the LCD Panel No other Defects of Alignment in Active area
Electrical current	Within device specifications
Function / Display	No Broken Circuit, No Short Circuit or No Black line No Other Defects of Display

