

DM137

Version : A.001
Issue Date : 2007/01/01
File Name : SP-DM137-A.001.doc
Total Pages: 32

16-bit Constant Current LED Driver with Error Detection



新竹市科學園區展業一路9號7樓之1
SILICON TOUCH TECHNOLOGY INC.
9-7F-1, Prosperity Road I, Science Based Industrial Park,
Hsin-Chu, Taiwan 300, R.O.C.
Tel : 886-3-5645656 Fax : 886-3-5645626

DM137

16-bit Constant Current LED Driver with Error Detection

General Description

DM137 is a constant-current sink driver specifically designed for LED display applications. The device incorporates shift registers, data latches, and constant current circuitry on the silicon CMOS chip. The maximum output current value of all 16 channels is adjustable by a single external resistor. Its built-in open/short detection and thermal alarm circuits help users detect LED failures and overheating. There are two methods to communicate the error messages to the system. One is through serial output data to indicate which channel has failure. The other is by means of dedicated Alarm pin.

Features

- Constant-current outputs: 5mA to 90mA adjustable by one external resistor
- Maximum output voltage: 17V
- Maximum clock frequency: 25MHz
- Built-in LED open/short detection: real-time monitor or smart detection modes
- Fast detecting response: 0.1us (min.)
- Over temperature protection:
 - Alarm (junction temperature > 110°C)
 - Shutdown (junction temperature > 180°C)
- Power supply voltage: 3.3V to 5.5V

Applications

- LED Variable Message Signs (VMS) System
- Indoor/Outdoor LED Video Display

Block Diagram

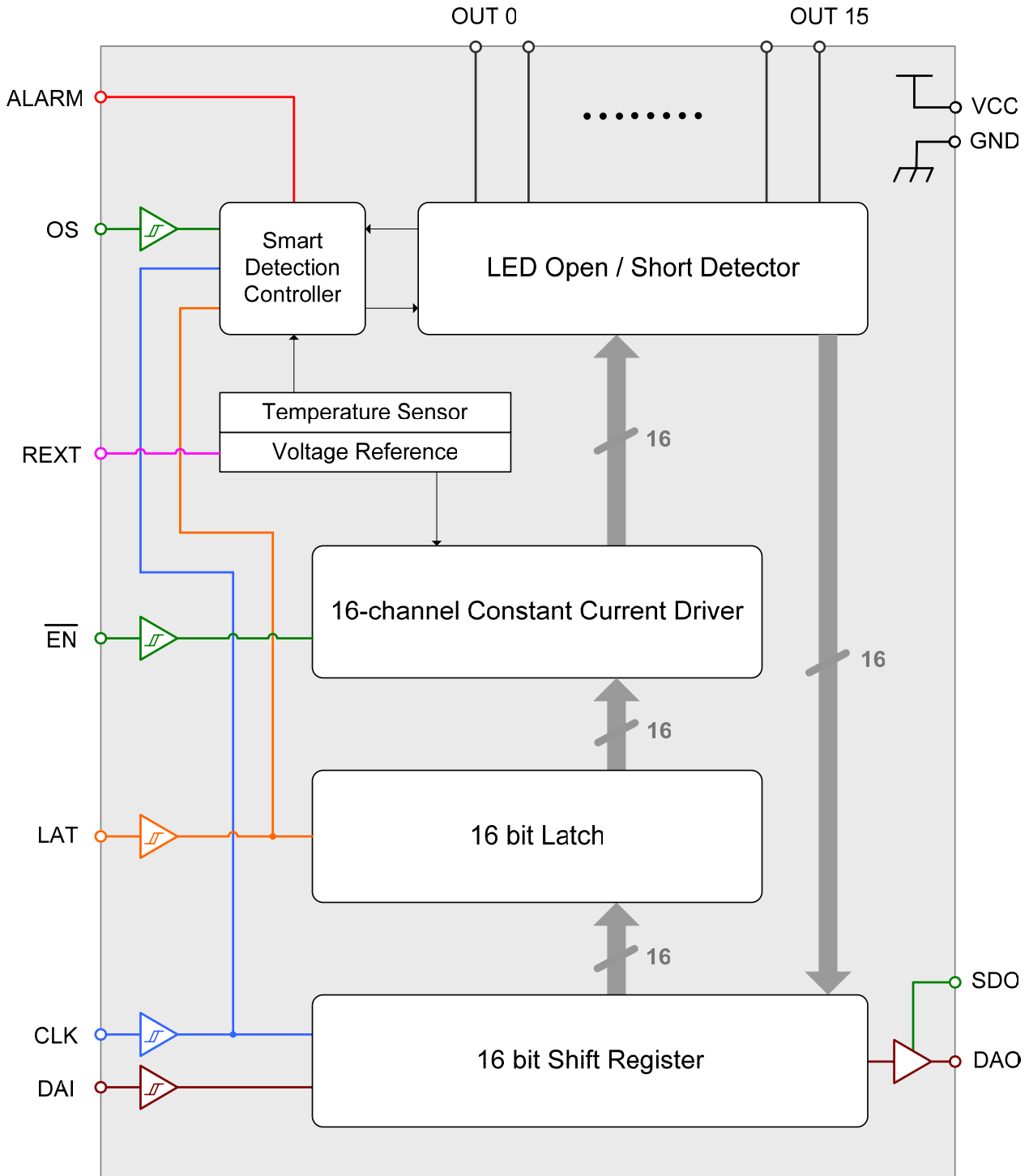

Pin Connection

SSOP28

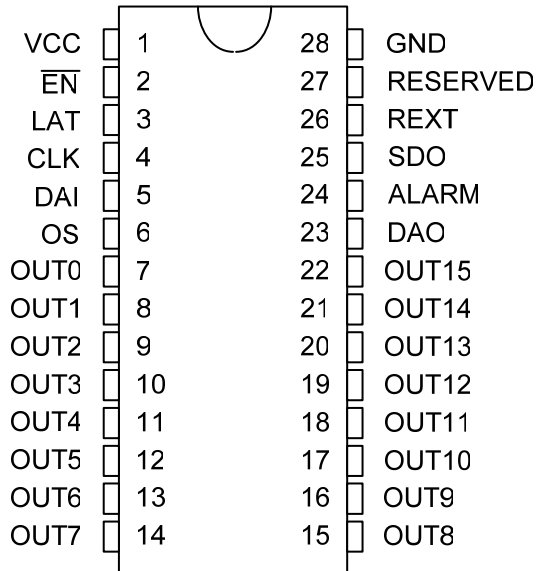

HSOP28

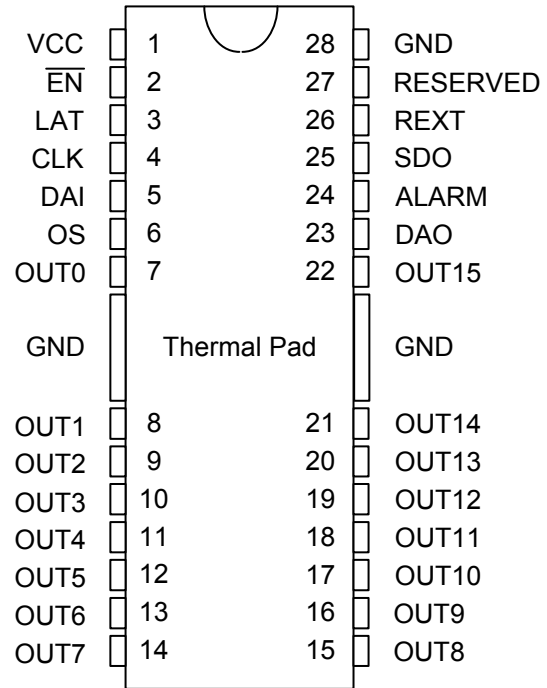

QFN32

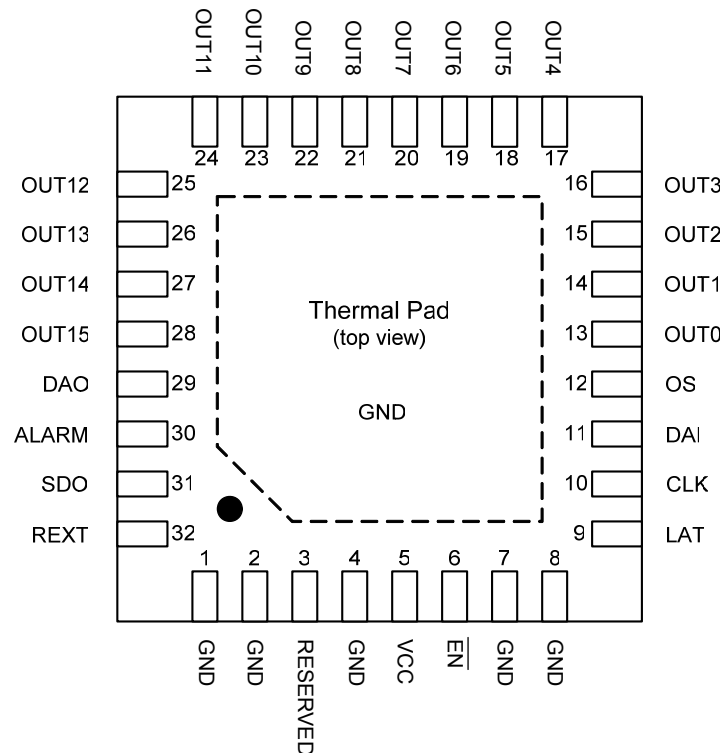



Pin Description

PIN No.	PIN NAME	FUNCTION
SSOP28/HSOP28: 1 QFN32: 5	VCC	Supply voltage terminal.
SSOP28/HSOP28: 2 QFN32: 6	$\overline{\text{EN}}$	Output enable terminal: 'H' for all outputs are turned off , 'L' for all outputs are active.
SSOP28/HSOP28: 3 QFN32: 9	LAT	Input terminal of data strobe. Data on shift register goes through at the rising edge of LAT (edge trigger). Otherwise, data is latched.
SSOP28/HSOP28: 4 QFN32: 10	CLK	Synchronous clock input terminal for serial data transfer. Data is sampled at the rising edge of CLK.
SSOP28/HSOP28: 5 QFN32: 11	DAI	Serial data input terminal.
SSOP28/HSOP28: 6 QFN32: 12	OS	Input open/short detection selection: 'H' for LED short detection mode, 'L' for LED open detection mode, 'Edge' ^{*1} for smart detection mode.
SSOP28/HSOP28: 7~22 QFN32: 13~28	OUT0~15	Sink constant-current outputs (open-drain).
SSOP28/HSOP28: 23 QFN32: 29	DAO	Serial data output terminal.
SSOP28/HSOP28: 24 QFN32: 30	ALARM	Output open drain terminal: (connected to a pull-high resistor) 'H' for normal conditions, 'L' for LED open/short or chip overheated.
SSOP28/HSOP28: 25 QFN32: 31	SDO	Serial data output trigger mode selection: 'H' means data is shifted out on synchronization to falling edge of CKO, 'L' means data is shifted out on synchronization to rising edge of CKO.
SSOP28/HSOP28: 26 QFN32: 32	REXT	External resistors connected between REXT and GND for output current value setting.
SSOP28/HSOP28: 27 QFN32: 3	RESERVED	Terminal for testing, user should leave this pin open.
SSOP28/HSOP28: 28 Thermal pad QFN32: 1, 2, 4, 7, 8 Thermal pad	GND	Ground terminal.

^{*1} Rising edge or falling edge. See detailed description (page 14~16).

Equivalent Circuit of Inputs and Outputs

1. CLK, DAI, LAT, SDO, $\overline{\text{EN}}$, OS terminals

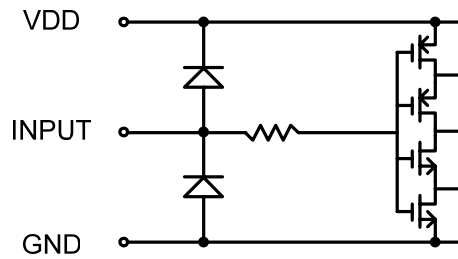

2. DAO terminals

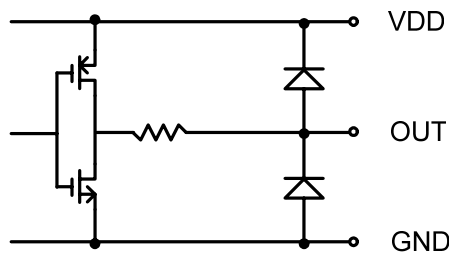

3. ALARM terminal

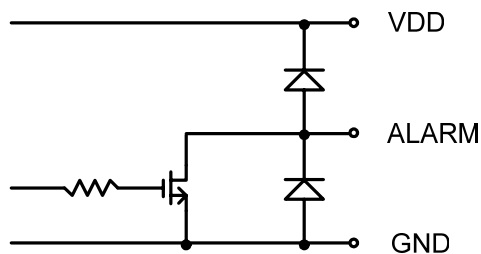



Maximum Ratings (Ta=25°C, Tj(max) = 150°C)

CHARACTERISTIC	SYMBOL	RATING	UNIT
Supply Voltage	VCC	-0.3 ~ 7.0	V
Input Voltage	VIN	-0.3 ~ VCC+0.3	V
Output Current	IOUT	100	mA
Output Voltage	VOUT	-0.3 ~ 17	V
Input Clock Frequency	FCKI	25	MHz
GND Terminal Current	IGND	1600	mA
Power Dissipation (4 layer PCB)	PD	1.1 (SSOP28 : Ta=25°C)	W
		2.11 (HSOP28 : Ta=25°C)	
		3.18 (QFN32 : Ta=25°C)	
Thermal Resistance	Rth(j-a)	113.3 (SSOP28)	°C/W
		59.1 (HSOP28)	
		39.3 (QFN32)	
Operating Temperature	Top	-40 ~ 85	°C
Storage Temperature	Tstg	-55 ~ 150	°C

Recommended Operating Condition

CHARACTERISTIC	SYMBOL	CONDITION	MIN.	TYP.	MAX.	UNIT
Supply Voltage	VCC	—	3.3	5.0	5.5	V
Output Voltage	VOUT	Driver On ^{*1}	1.0	—	0.5VCC	V
Output Voltage	VOUT	Driver Off ^{*2}	—	—	17	
Output Current	IO	OUTn	5	—	90	mA
	IOH	VOH = VCC – 0.2 V	—	—	+1.6	
	IOL	VOL = 0.2 V	—	—	-1.5	
Input Voltage	VIH	VCC = 3.3 V ~ 5.5V	0.8VCC	—	VCC	V
	VIL		0.0	—	0.2VCC	
Input Clock Frequency	FCKI	Single Chip Operation	—	—	25	MHz
		Cascade Operation (SDO='H', CL=13pF)			15	
		Cascade Operation (SDO='L', CL=13pF)			25	
LAT Pulse Width	tw LAT	VCC = 5.0V	15	—	—	ns
CLK Pulse Width	tw CLK		15	—	—	
EN Pulse Width	tw EN		15	—	—	
OS Pulse Width	tw OS		15	—	—	
Set-up Time for DAI	tsetup(D)		10	—	—	
Hold Time for DAI	thold(D)		10	—	—	
Set-up Time for LAT	tsetup(L)		10	—	—	
Hold Time for LAT	thold(L)		10	—	—	
Set-up Time for OS	tsetup(O)		25	—	—	
Open/Short Detection Response	tdet		100	—	—	

*1 Notice that the power dissipation is limited to its package and ambient temperature.

*2 The driver output voltage including any overshoot stress has to be compliant with the maximum voltage (17V).



Electrical Characteristics (VCC = 5.0 V, Ta = 25°C unless otherwise noted)

CHARACTERISTIC	SYMBOL	CONDITION	MIN.	TYP.	MAX.	UNIT
Input Voltage "H" Level	VIH	CMOS logic level	0.8VCC	—	VCC	V
Input Voltage "L" Level	VIL	CMOS logic level	GND	—	0.2VCC	
Input Leakage Current	I _{IH}	VIH = VCC	—	—	1.0	uA
	I _{IL}	VIL = GND	—	—	1.0	
Output Leakage Current	IOL	VOH = 17 V	—	—	±1.0	uA
Output Voltage (S-OUT)	VOL	IOL = 1.5 mA	—	—	0.2	V
	VOH	IOH = 1.6 mA	VCC-0.2	—	—	
Output Current Skew (Channel-to-Channel) * ¹	IOL1	VOUT = 1.0 V R _{rext} = 2.2 KΩ	—	—	±3	%
Output Current Skew (Chip-to-Chip) * ²	IOL2		23.5	25	26.5	mA
Output Voltage Regulation	% / VOUT	R _{rext} = 2.2 KΩ VOUT = 1 V ~ 3 V	—	±0.1	±0.5	% / V
Supply Voltage Regulation	% / VCC	R _{rext} = 2.2 KΩ	—	±1	±4	
LED Open Detection Threshold	V(od)	all outputs turn on	—	0.3	—	V
LED Short Detection Threshold	V(sd)		—	0.5VCC	—	
Thermal Alarm Threshold	T(alm)	junction temperature	—	110	—	°C
Thermal Shutdown Threshold	T(sht)		—	180	—	
Supply Current * ³	I _{DD(off)}	power on all pins are open unless VCC and GND	—	3.0	—	mA
	I _{DD(off)}	input signal is static R _{rext} = 2.9 KΩ all outputs turn off	—	4.8	—	
	I _{DD(on)}	input signal is static R _{rext} = 2.9 KΩ all outputs turn on	—	6.5	—	
	I _{DD(on)}	input signal is static R _{rext} = 560 Ω all outputs turn off	—	12.5	—	
	I _{DD(on)}	input signal is static R _{rext} = 560 Ω all outputs turn on	—	14.7	—	

*¹ Channel-to-channel skew is defined as the ratio between (any I_{out} – average I_{out}) and average I_{out}, where average I_{out} = (I_{max} + I_{min}) / 2.

*² Chip-to-Chip skew is defined as the range into which any output current of any IC falls.

*³ IO excluded.

Switching Characteristics (VCC = 5.0V, Ta = 25°C unless otherwise noted)

CHARACTERISTIC		SYMBOL	CONDITION	MIN.	TYP.	MAX.	UNIT
Propagation Delay (‘L’ to ‘H’)	EN-to-OUT15	tpLH	VIH = VCC VIL = GND R _{rext} = 2.9 KΩ VL = 5.0 V CL ^{*1} = 13 pF Ra = 470 Ω	—	18	—	ns
	LAT-to-OUT15			—	20	—	
	CLK-to-DAO (SDO = ‘L’)			—	22	—	
	CLK-to-DAO (SDO = ‘H’)			—	15	—	
Propagation Delay (‘H’ to ‘L’)	EN-to-OUT15	tpHL		—	22	—	
	LAT-to-OUT15			—	15	—	
	CLK-to-DAO (SDO = ‘L’)			—	20	—	
	CLK-to-DAO (SDO = ‘H’)			—	14	—	
Output Current Rise Time		tor	—	4.0	—		
Output Current Fall Time		tof	—	6.0	—		
Output Delay Time (OUT _(n) -to-OUT _(n+1))		tod	—	2.0	—		

Switching Characteristics (VCC = 3.3V, Ta = 25°C unless otherwise noted)

CHARACTERISTIC		SYMBOL	CONDITION	MIN.	TYP.	MAX.	UNIT
Propagation Delay (‘L’ to ‘H’)	EN-to-OUT15	tpLH	VIH = VCC VIL = GND R _{rext} = 2.9 KΩ VL = 5.0 V CL ^{*1} = 13 pF Ra = 470 Ω	—	35	—	ns
	LAT-to-OUT15			—	27	—	
	CLK-to-DAO (SDO = ‘L’)			—	20	—	
	CLK-to-DAO (SDO = ‘H’)			—	18	—	
Propagation Delay (‘H’ to ‘L’)	EN-to-OUT15	tpHL		—	24	—	
	LAT-to-OUT15			—	31	—	
	CLK-to-DAO (SDO = ‘L’)			—	18	—	
	CLK-to-DAO (SDO = ‘H’)			—	19	—	
Output Current Rise Time		tor	—	43	—		
Output Current Fall Time		tof	—	9.0	—		
Output Delay Time (OUT _(n) -to-OUT _(n+1))		tod	—	2.8	—		

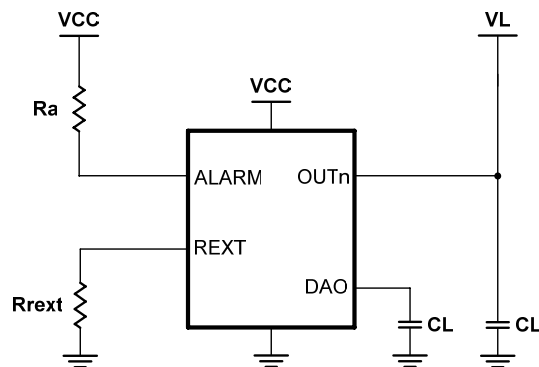

Switching Characteristics Test Circuit

*1 CL means the probe capacitance of oscilloscope.

Timing Diagram

1. CLK-DAI, DAO

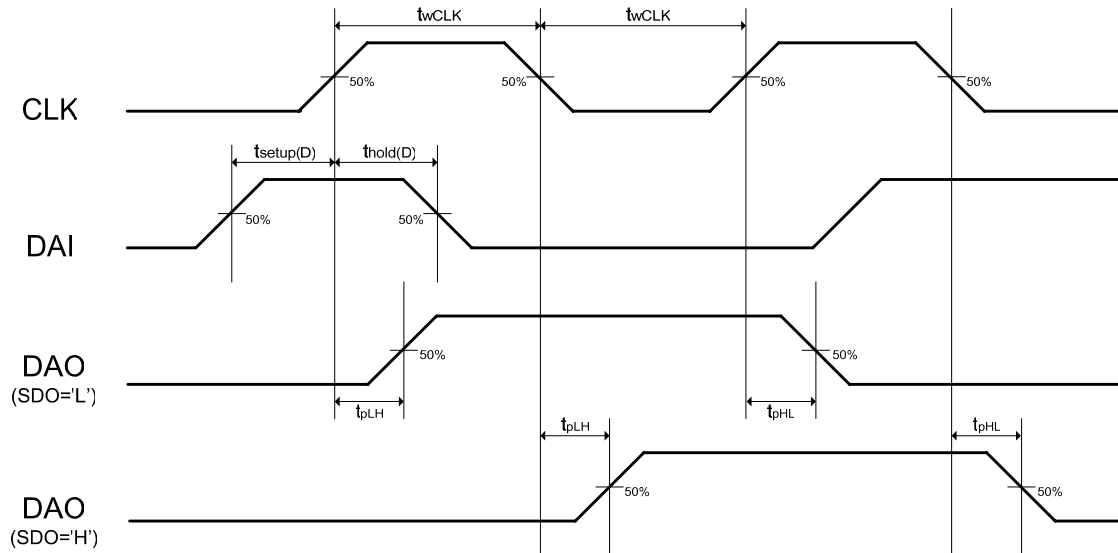

2. CLK-LAT

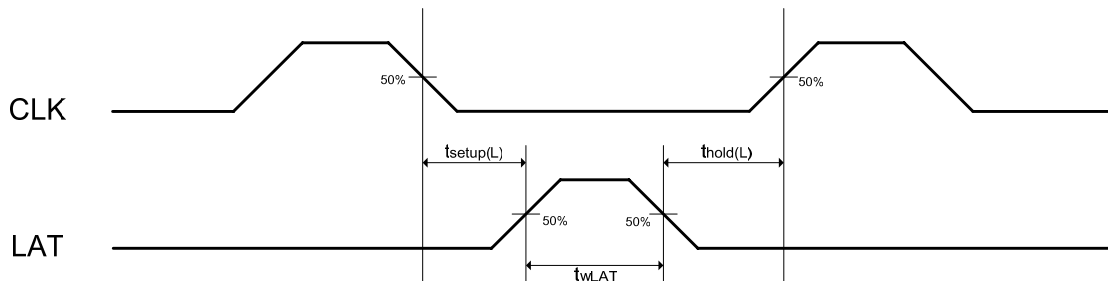

3. LAT-OUT15

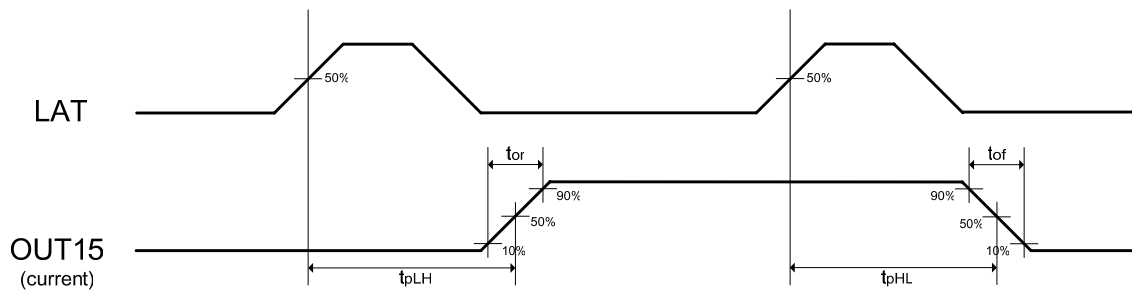

4. \overline{EN} -OUT15

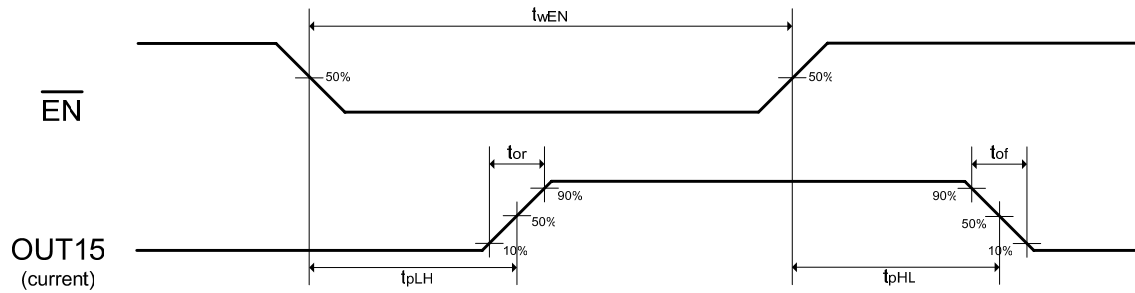

5. OUT_{n+1} - OUT_n

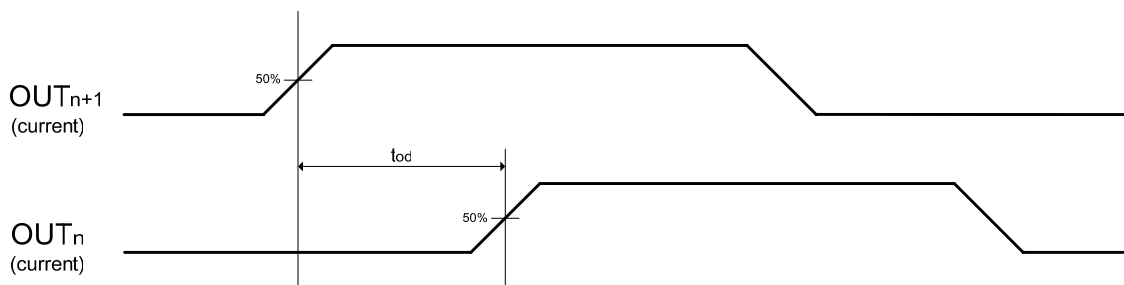

6. OS-LAT, CLK (\overline{EN} 'L')

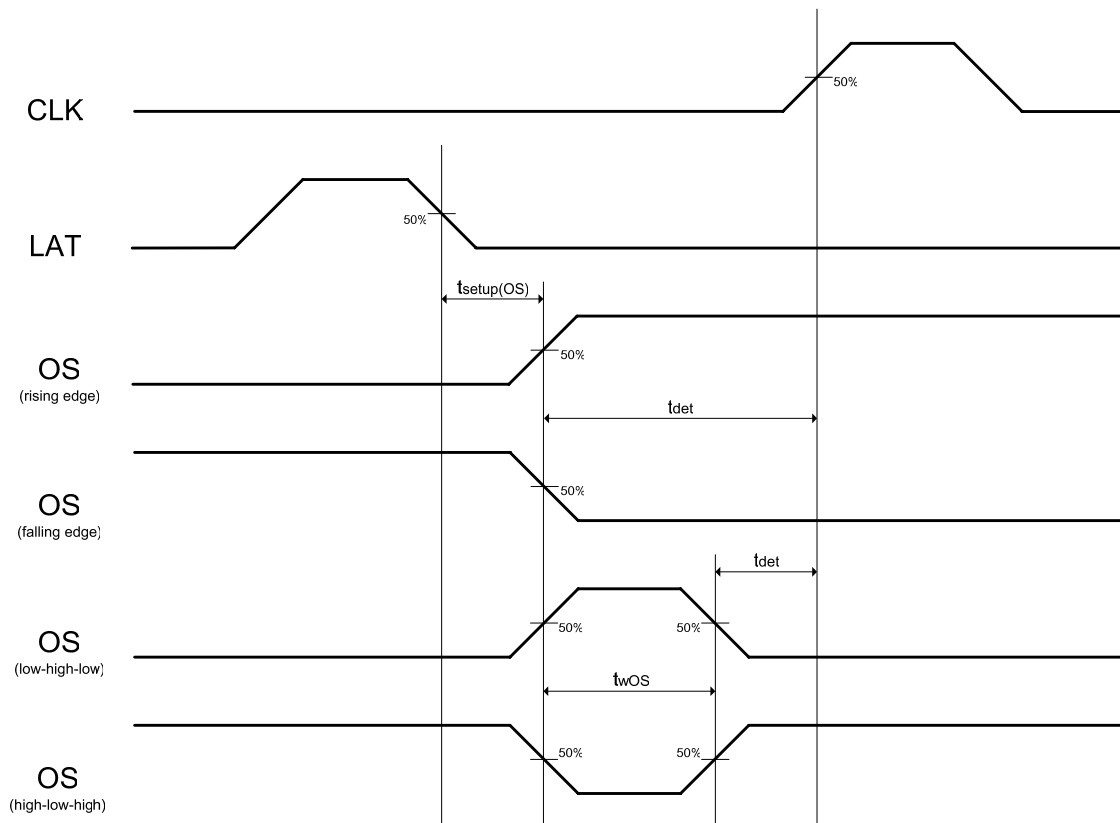

Constant-Current Output

Constant-current value of each output channel is set by an external resistor connected between the REXT pin and GND. The current scale ranging can be adjusted from 5mA to 90mA by varying the resistor value. The reference voltage of REXT terminal (V_{rxt}) is approximately 0.6V. The output current value is calculated by the following equation:

lout(mA)	5	10	20	30	40	50	60	70	80	90
M	99.7	98.1	96.0	94.2	92.5	90.8	89.1	87.1	85.1	84.4

Output Current as a Function of Rrxt value

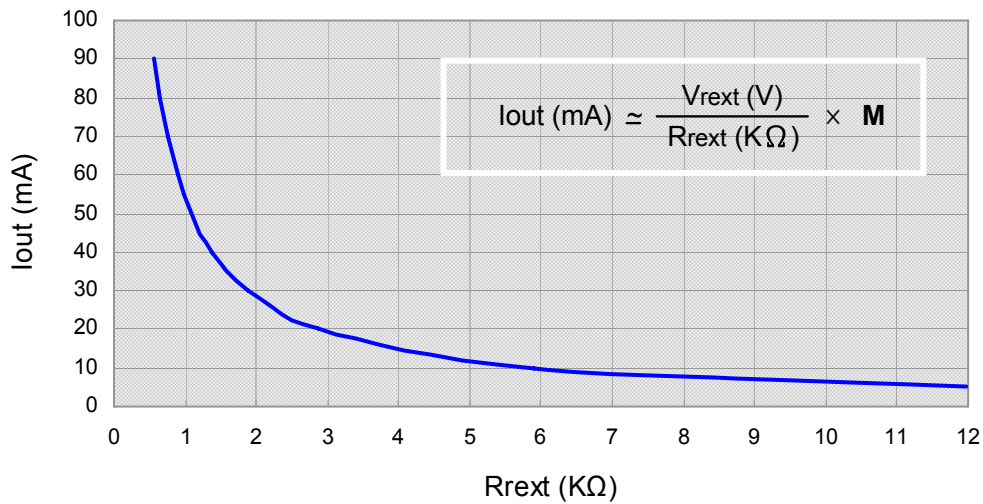

Output Current as a Function of Output Voltage

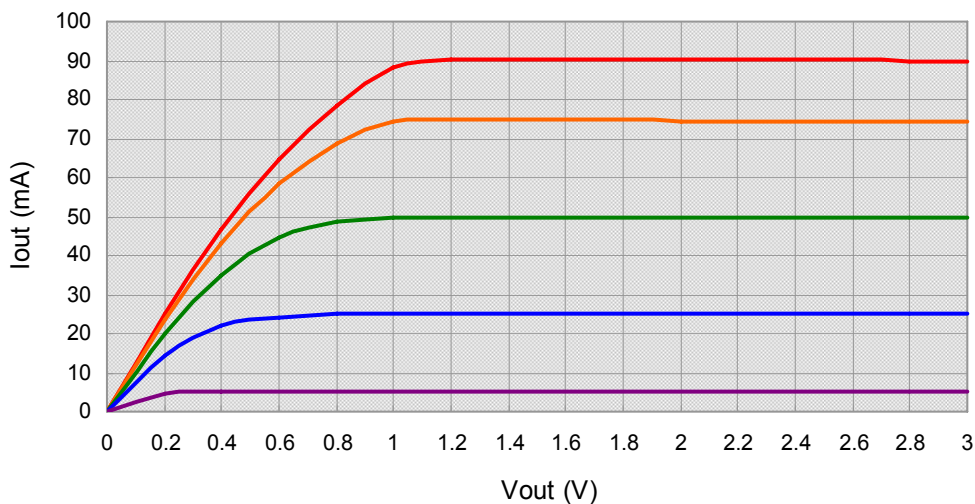

In order to obtain a good performance of constant-current output, a suitable output voltage is necessary. Users can get related information about the minimum output voltage above.

Serial Data Interface

The serial-in data (DAI) will be clocked into 16 bit shift register synchronized on the rising edge of the clock (CLK). The data '1' represents the corresponding current output 'ON', while the data '0' stands for 'OFF'. The data will be transferred into the 16 bit latch synchronized on the rising edge of the strobe signal (LAT); otherwise, the data will be latched. The latch pulse should be sent after the falling edge of the last clock within a frame data.

The trigger timing of the serial-out data (DAO) can be selected by the SDO pin. When SDO is set to 'H', the data will be shifted out on synchronization to the falling edge of the clock (CLK). And when SDO is set to 'L', the data will be shifted out on synchronization to the rising edge of the clock.

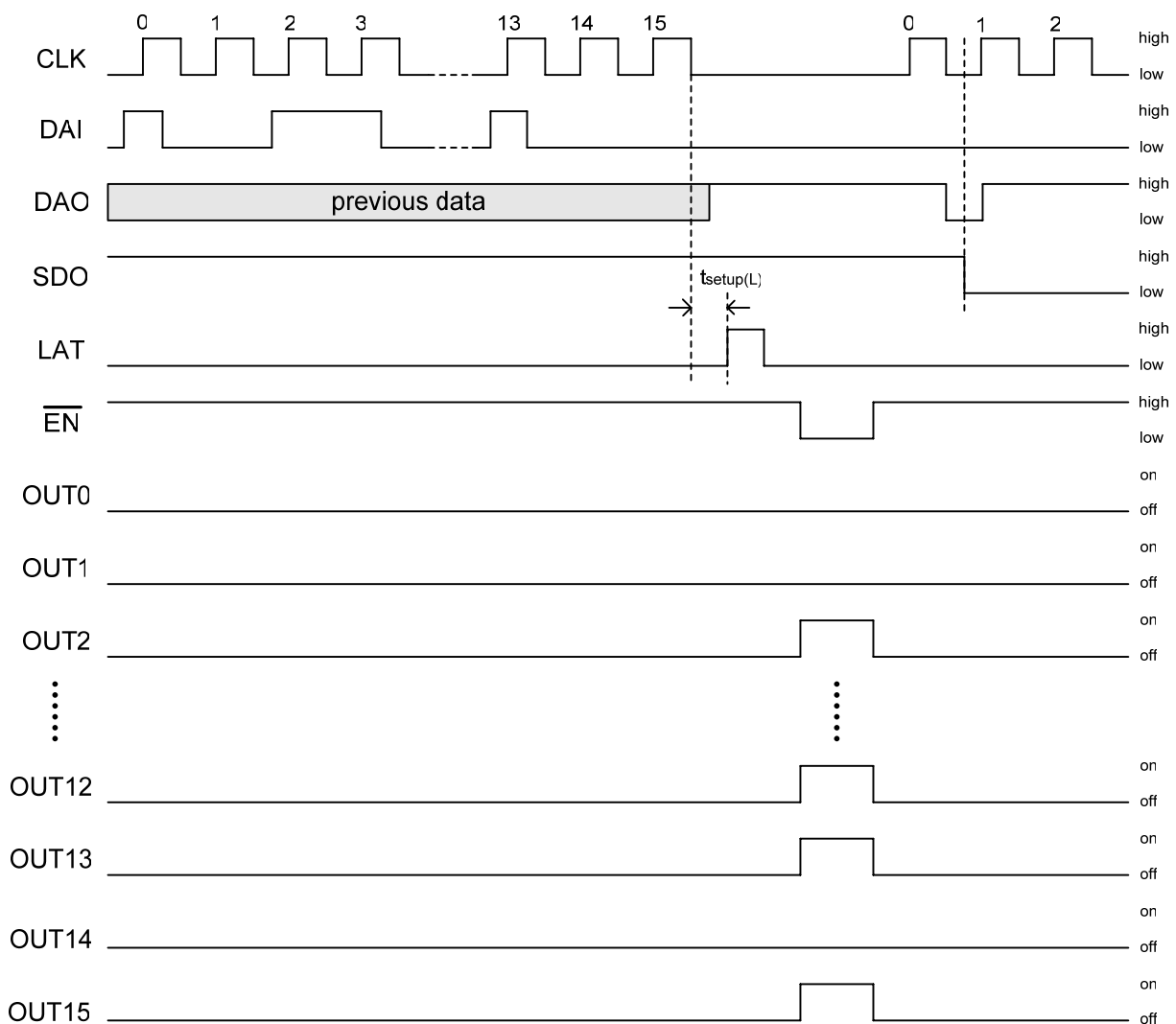

Alarm Function

It can detect the operating status by connecting a pull-high resistor to the open-drain ALARM pin. The ALARM pin is kept 'H' for normal conditions, and shifted to 'L' if there is any failure like LED open/short, overheating or both occurrence. User can determine the different status from the truth table below:

ALARM	\overline{EN}	OS	Status
H	L	don't care	Normal Operation
H→L	L	L	LED Open or Thermal issue
H→L	L	H	LED Short or Thermal issue
H→L	H	don't care	Thermal Alarm or Shutdown

When the latch is at its rising edge, the ALARM pin will reset to high level and start to detect once again. It will send out the test result after the next clock pulse. The detection cycle of the alarm signal will continue until it reaches the rising edge of the latch pulse again. Please see the timing diagram below:

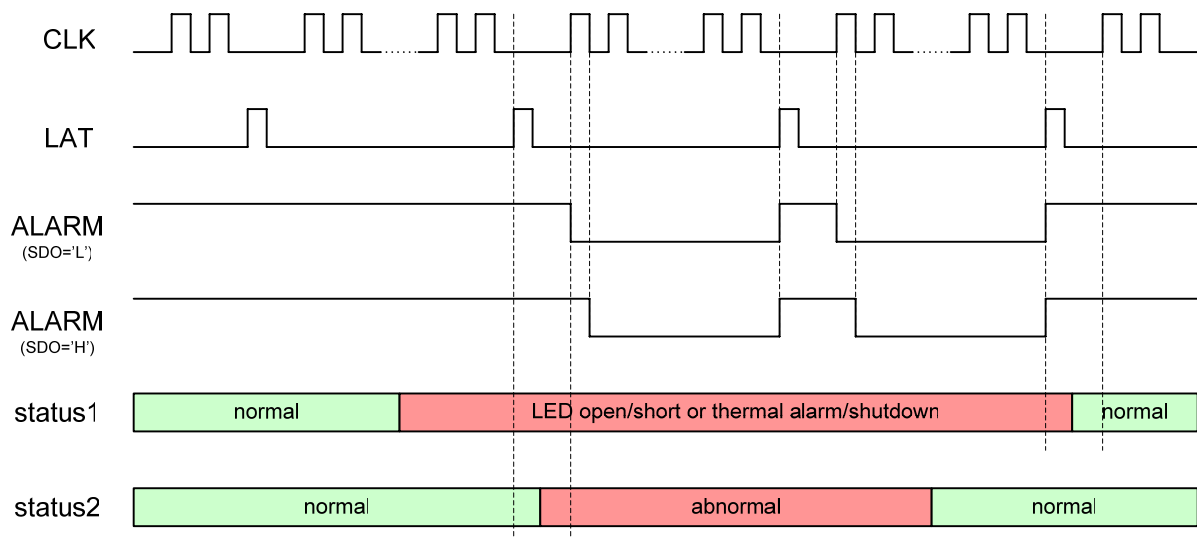

For actual application, the controller could connect all the ALARM pins with one pull-high resistor to simplify circuit designs and feedback loops.

Thermal Alarm and Shutdown

During operation, when the junction temperature of the IC will reach about 110°C, the ALARM pin will shift to low level and produce a warning signal. Suggested cooling measures is to start the fan, lower the output currents and etc. If no cooling measures were activated, the junction temperature might continue to rise. Once it reaches approximately above 180°C, it will cause the driver to shutdown all the outputs. Basically, the IC will cool down and return to the safe operating temperature which is approximately below 110°C. The ALARM pin will reset to high level, disable the warning, and restart all the outputs at the same time. Operation in the thermal situation for a long time may cause chip damage permanently.

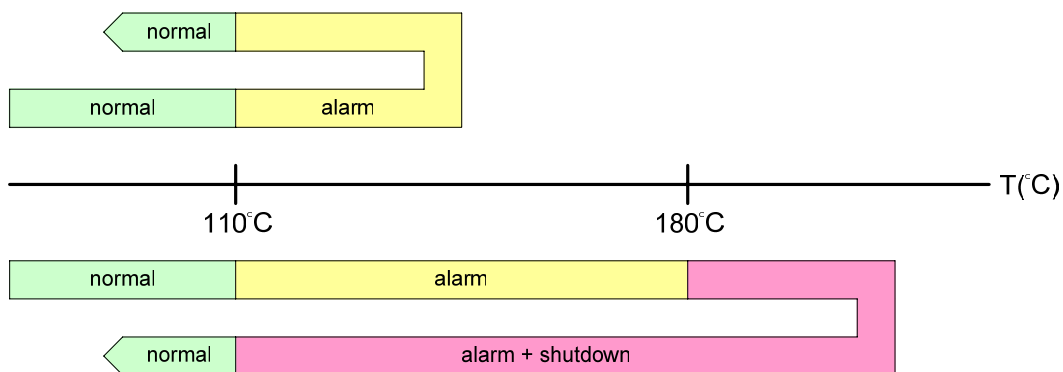

Relations between Alarm Function and Junction Temperature

LED Open/Short Detection

Test result of DM137's open/short detection could be retrieved from ALARM pin or serial-out (DAO) data. Setting the OS pin to low level (L) will activate OPEN detection; which identifies a LED open failure when there is a current passing through the output but the voltage is below 0.3V. Setting the OS pin to high level (H) will activate SHORT detection; which identifies a LED short failure when there is a current passing through the output but the voltage is above 1/2 VCC.

DM137 will execute LED open/short detection then save the result within the particular shift register with the following conditions: 1) the shift register corresponding the particular output channel saves an image data of '1', 2) the output enable terminal is activated (EN='L'), and 3) the rising edge of the latch pulse takes place. By using the error message sent by serial-out, the controller can identify the status of every LED driven by each channel. For the process of either

open or short detection, the image data of the particular channel is always sent as '1', however, if '0' is retrieved, there must be a LED failure. If the input of image data is '0' or the output enable terminal is inactive (EN='H'), it will not execute any detection for the particular channel. The original image data will be retrieved by serial-out.

With the above operating principle, the controller could continuously retrieve data from serial-out and compare it with the frame data which have been sent and kept in the memory one by one. Therefore, once any discrepancy occurs ('1'→'0'), any fail LED of a particular channel can be clearly identified. Since the detection is now a continuous action, and is able to exist without shifting between image and detection modes, it does not interrupt the image data flow and the output display. This is known as “**real-time monitor**”.

The above mentioned detection method is more suitable for LED Variable Message Signs(VMS) system. However, for large LED display applications, there could be an additional load to the system since the frame data that needs to be compared and retrieved is greater within the memory. Therefore, DM137 provides two alternative solutions for LED open/short detection: The first solution is to activate the output enable terminal (EN='L') and send image data of '1' to all channels. Failures will be identified when any data of '0' is retrieved from serial-out. By counting the number of clock pulse, failure channels can be pointed out accurately. With this solution the load and memory resource of the system can be greatly minimized.

The second method, which is also known as DM137's “smart” detection, is triggered by using any change of edge (including rising edge, falling edge, low-high-low, high-low-high) produced by OS pin. It is recommended placing the signal between strobe signal (LAT) and the first clock (CLK) of one frame data will activate the detection. LED's open or short failure is determined by the final kept level of the OS pin. Turn on all output channels (EN='L') simultaneously, DM137 will complete the following two actions automatically:

- 1) Resetting all image data stored within latch registers to '1'. This will save the system resources and the time of sending at least one frame containing all image data of '1' mentioned before.

- 2) Lowering the maximum output current at the same time to about 1/10 of its original value until the next rising edge of the latch pulse. This is to prevent a glitch perceived when all outputs are turned on. Finally, counting again the clock to identify the locations of any channels with fail LED. The impression of “**invisible failure detection**” is achievable.

Timing Diagram for LED Open/Short Detection

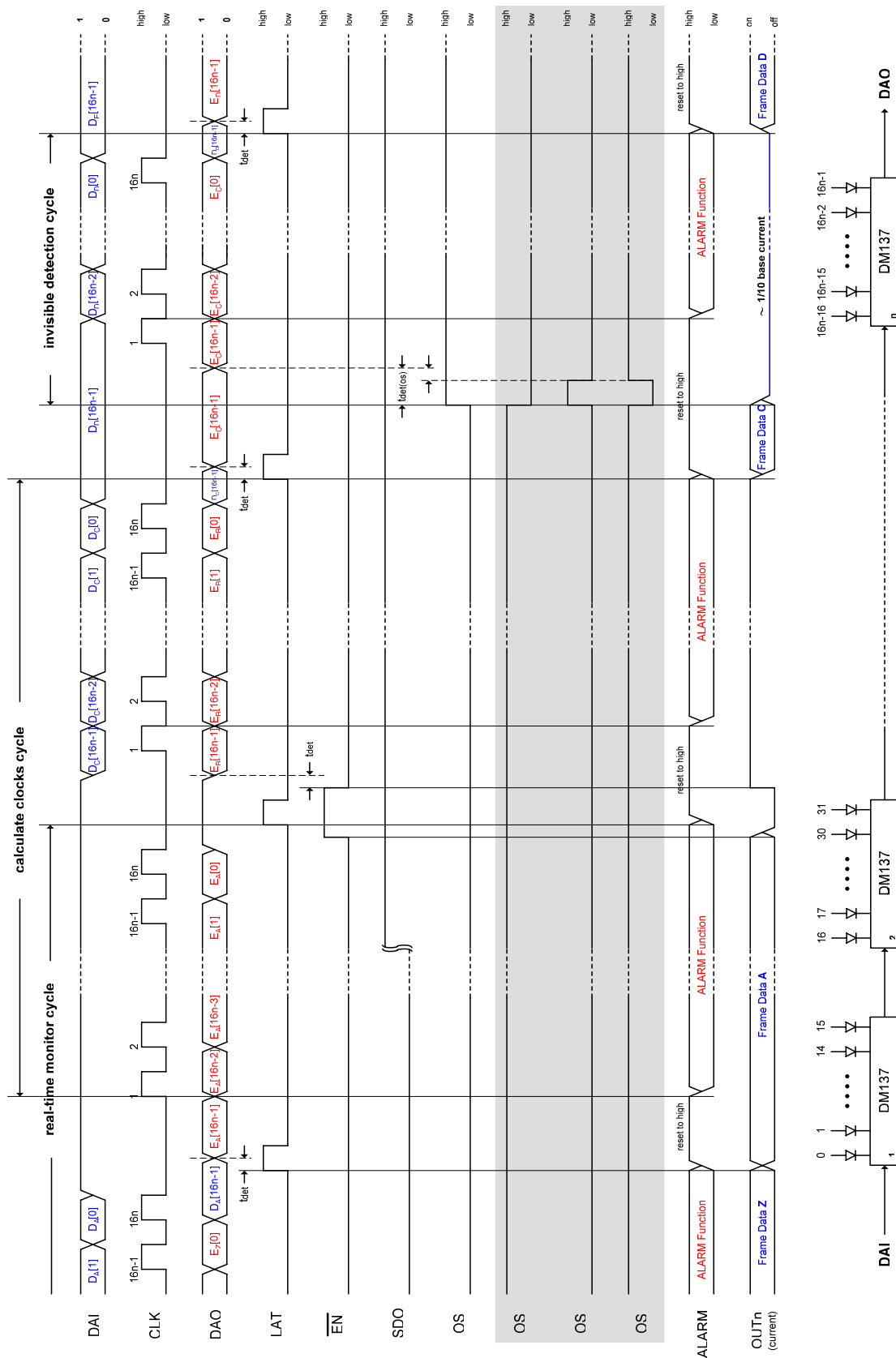

There are **n** x DM137 connected in cascade. **D[x]** : Image Data **E[x]** : Error Message of LED Open/Short Detection

Threshold for Short Detection

The default threshold voltage for LED short detection of DM137 is $\frac{1}{2} V_{CC}$. One could change the default voltage by switching or setting a new voltage of V_{LED} during short detection is going on. Please see the example below for reference:

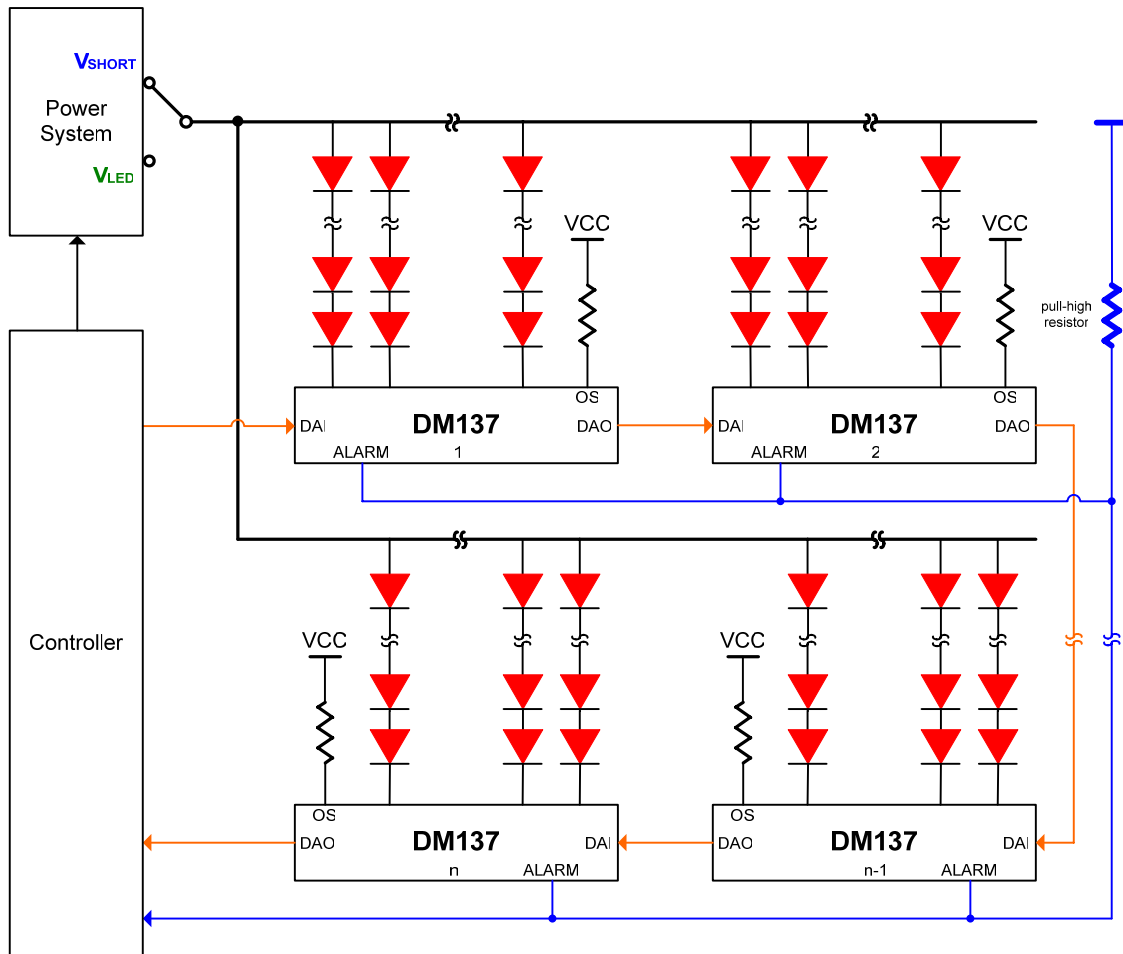

Example for shifting the threshold of LED short detection

Note that the V_{SHORT} should be satisfied with the following inequality:

$$\frac{1}{2} V_{CC} < V_{SHORT} < \frac{1}{2} V_{CC} + V_{F(LED \text{ forward voltage})} \times N_{(Numbers \text{ of LED in a string})}$$

The new threshold voltage of short detection will be equivalent to:

$$\frac{1}{2} V_{CC} + (V_{LED} - V_{SHORT})$$

Outputs Delay

Large in-rush currents will occur when the system activates all the outputs at once. To reduce this effect, DM137 is designed to have a constant unit of delay (around 2ns) between outputs. The delay for every output goes like this: there is no delay for OUT15 and OUT7, 1 unit of delay for OUT14 and OUT6, 2 units of delay for OUT13 and OUT5 and so on.

Global Brightness Control

DM137 has no built-in global brightness control feature. In order to obtain a lower resolution of global brightness control effect, two methods could be utilized. One is providing PWM signal synchronized on latch pulse to modulate the output enable terminal (\overline{EN} pin). The other is to adjust the R_{rest} value or voltage drop across the external resistor. Please see the reference circuit below:

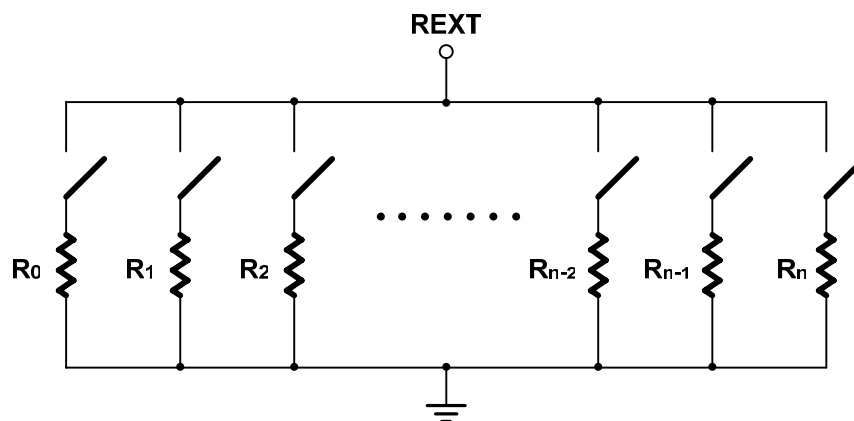

Global Brightness Control with Resistor Ladder

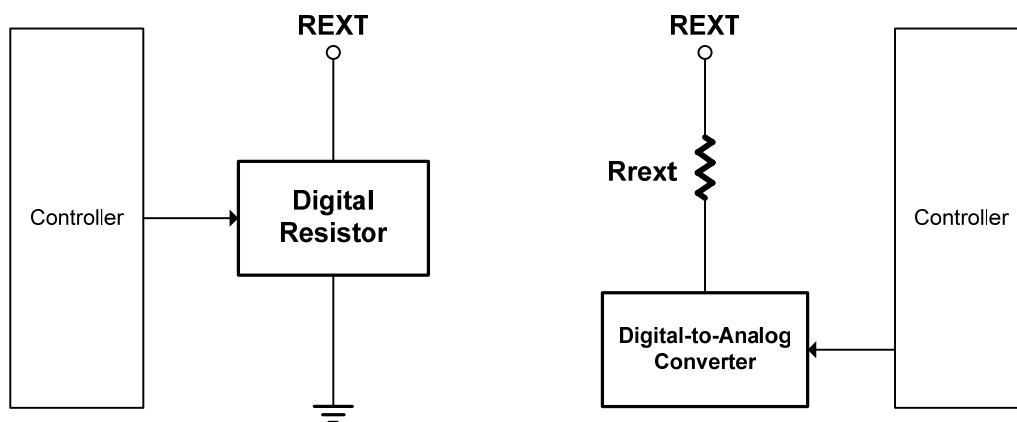

Global Brightness Control with Digital Resistor

Global Brightness Control with D/A converter

Power Dissipation

The power dissipation of a semiconductor chip is limited to its package and ambient temperature, in which the device requires the maximum output current calculated for given operating conditions. The maximum allowable power consumption can be calculated by the following equation:

$$Pd(max)(Watt) = \frac{Tj(junction\ temperature)(max)(\text{ }^{\circ}C) - Ta(ambient\ temperature)(\text{ }^{\circ}C)}{Rth(junction\text{-to}\text{-air\ thermal\ resistance})(\text{ }^{\circ}C/Watt)}$$

The relationship between power dissipation and operating temperature can be refer to the figure below:

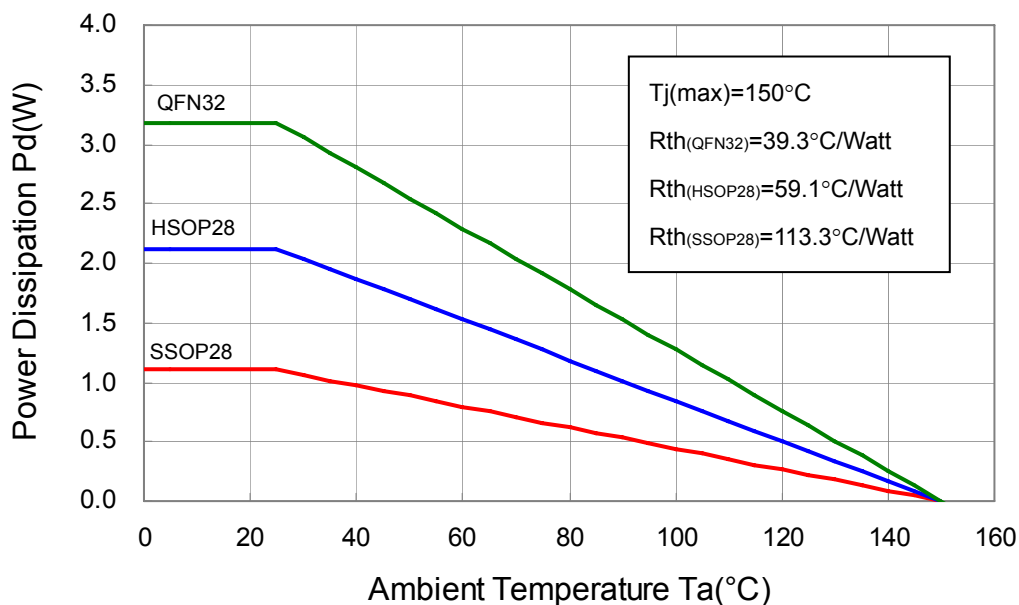

The power consumption of IC can be determined by the following equation and should be less than the maximum allowable power dissipation:

$$Pd(W) = Vcc(V) \times I_{DD}(A) + V_{out0} \times I_{out0} \times Duty_0 + \dots + V_{out15} \times I_{out15} \times Duty_{15} \leq Pd(max)(W)$$

Package Outline Dimension

DM137-SSOP

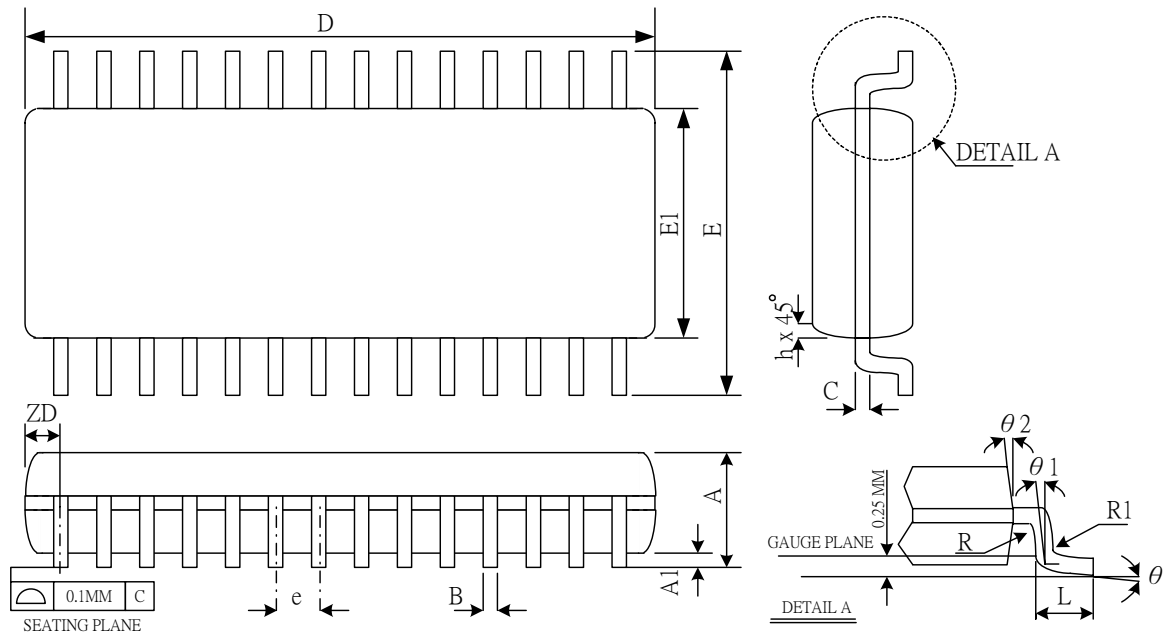

NOTES: DIMENSION D DOES NOT INCLUDE MOLD PROTRUSIONS OR GATE BURRS.
MOLD PROTRUSIONS AND GATE BURRS SHALL NOT EXCEED 0.006 INCH PER SIDE

SYMBOL	DIMENSION IN MM			DIMENSION IN INCH		
	MIN.	NOM.	MAX.	MIN.	NOM.	MAX.
A	1.35	1.63	1.75	0.053	0.064	0.069
A1	0.1	0.15	0.25	0.004	0.006	0.01
A2			1.5			0.059
B	0.2		0.3	0.008		0.012
C	0.18		0.25	0.007		0.01
e	0.635 BASIC			0.025 BASIC		
D	9.80	9.91	10.01	0.386	0.39	0.394
E	5.79	5.99	6.20	0.228	0.236	0.244
E1	3.81	3.91	3.99	0.150	0.154	0.157
L	0.41	0.635	1.27	0.016	0.025	0.05
h	0.25		0.5	0.01		0.02
ZD	0.838 REF			0.033 REF		
R1	0.2		0.33	0.008		0.013
R	0.2			0.008		
θ	0		8	0		8
$\theta 1$	0			0		
$\theta 2$	5	10	15	5	10	15
JEDEC	MO - 137 (AF)					



Package Outline Dimension

DM137-HSOP

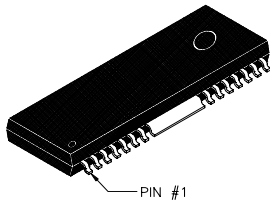
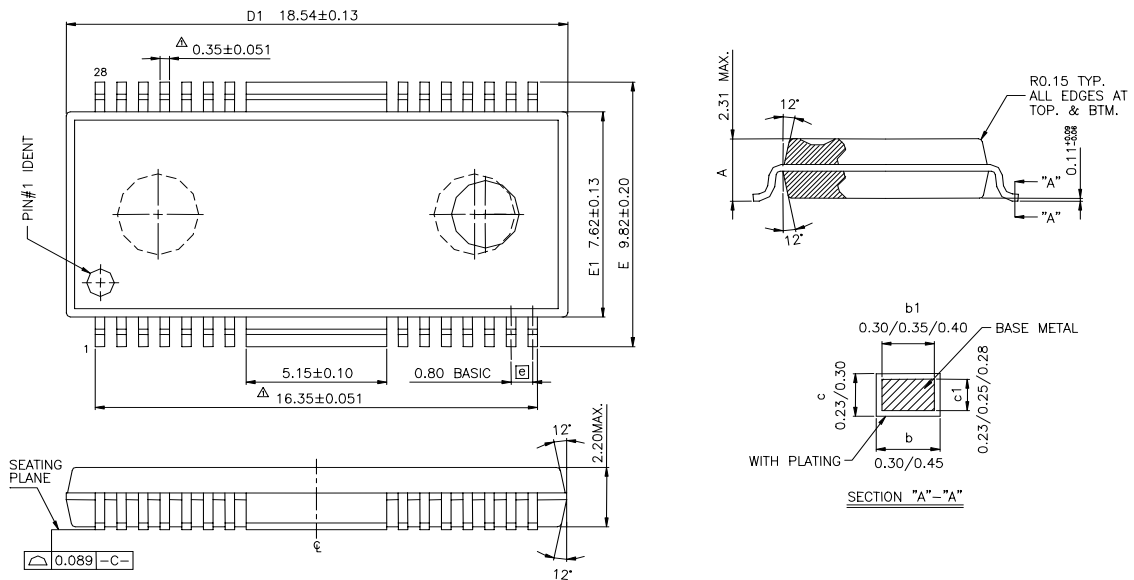

FORM:EG00005.C

- NOTES:
1. CONTROLLING DIMENSIONS ARE IN MILLIMETERS (MM).
 2. DIMENSION D1&E1 DOES NOT INCLUDE MOLD PROTRUSION.
 3. COPLANARITY OF ALL LEADS SHALL BE (BEFORE TEST) 0.089 MM MAX. FROM THE SEATING PLANE. UNLESS OTHERWISE SPECIFIED.
 4. GENERAL PHYSICAL OUTLINE SPEC IS REFER TO TMC'S FINAL VISUAL INSPECTION SPEC UNLESS OTHERWISE SPECIFIED.

Package Outline Dimension

DM137-QFN

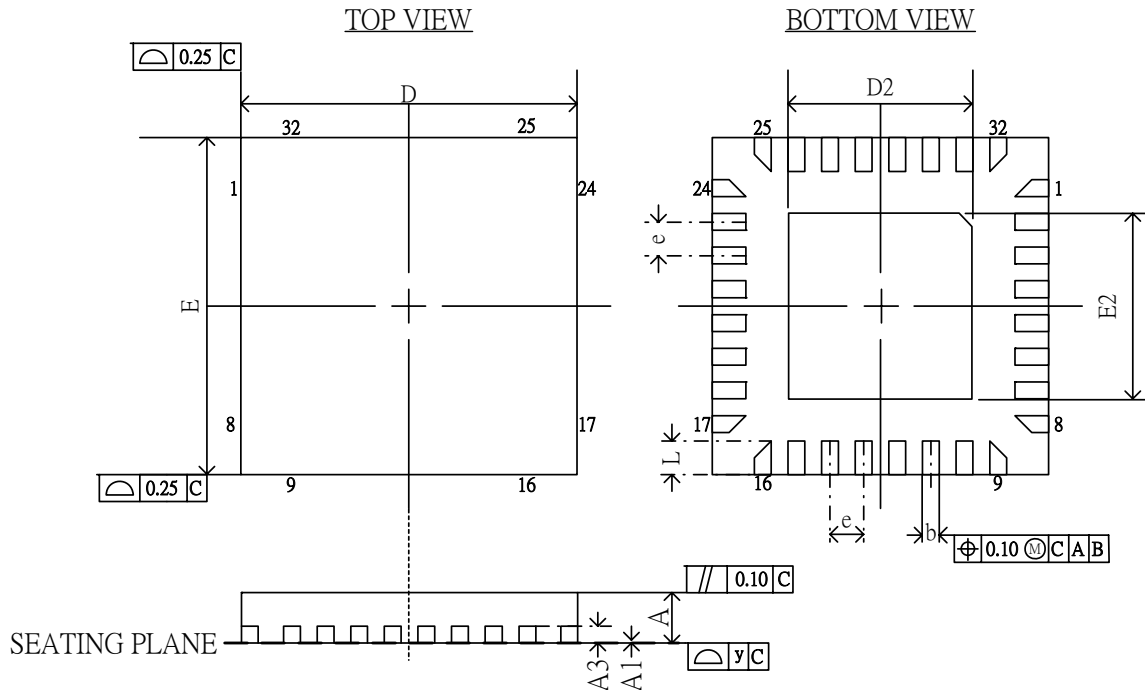

SYMBOL	DIMENSION (mm)			DIMENSION (MIL)		
	MIN.	NOM.	MAX.	MIN.	NOM.	MAX.
A	0.70	0.75	0.80	27.6	29.5	31.5
A1	0	0.02	0.05	0	0.79	1.97
A3	0.25 REF			9.84 REF		
b	0.18	0.23	0.30	7.09	9.06	11.81
D	5.00 BSC			196.85 BSC		
D2	1.25	2.70	3.25	49.21	106.30	127.95
E	5.00 BSC			196.85 BSC		
E2	1.25	2.70	3.25	49.21	106.30	127.95
e	0.50 BSC			19.69 BSC		
L	0.30	0.40	0.50	11.81	15.75	19.69
y	0.10			3.94		

Note: 1. DIMENSIONING AND TOLERANCING CONFORM TO ASME Y145.5M-1994.

2. REFER TO JEDEC STD. MO-220 WHHD-2 ISSUE A

DM137-SSOP Package and Weight (4 Boxes Set)

SSOP28 - 150 - 0.65

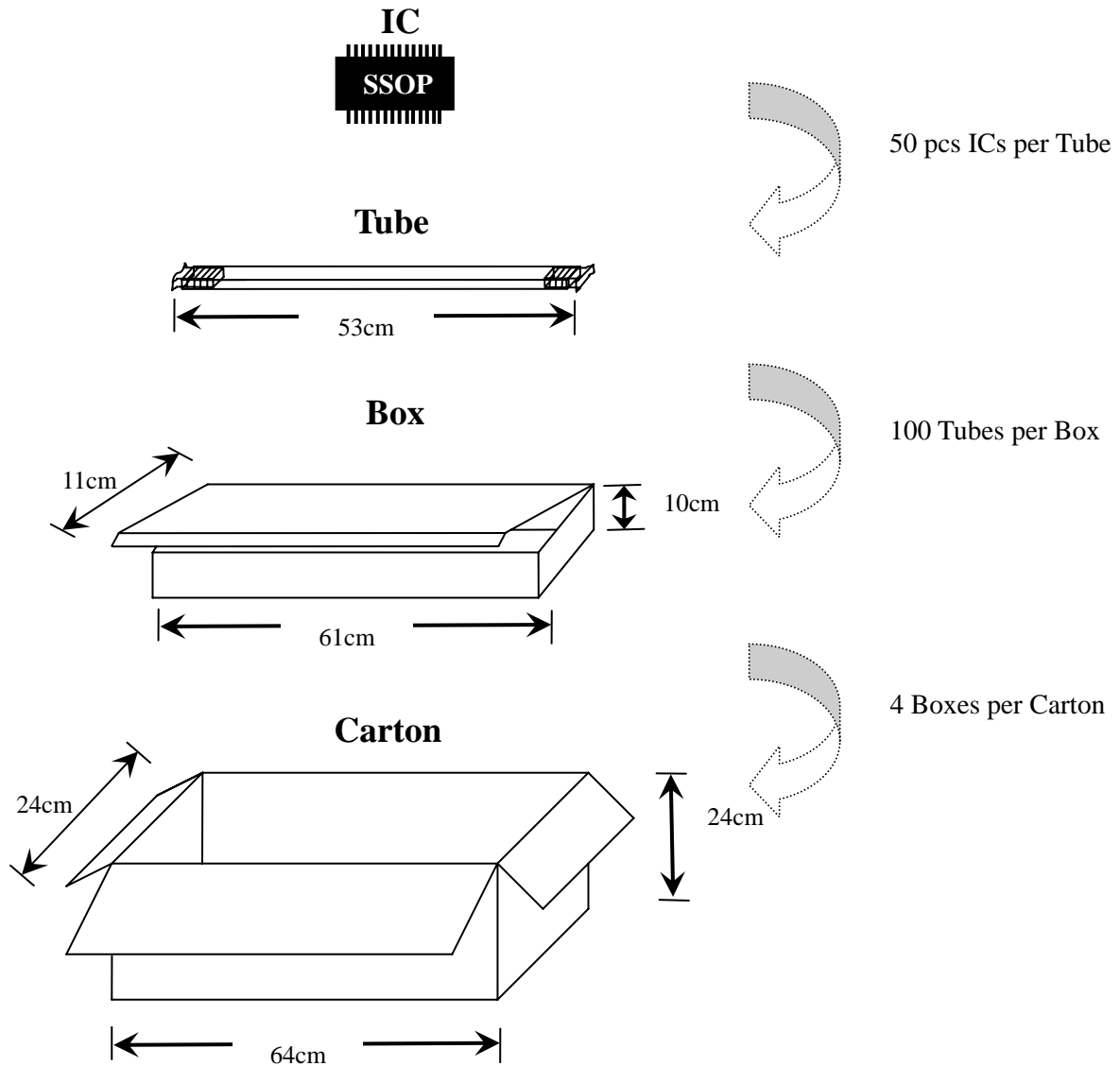

Weight

Item	Description	Weight (Kg)
1	50 pcs DM137-SSOP per Tube	0.016±5%
2	Net Weight of one Box	0.40±5%
3	Net Weight of one Carton	1.24±5%
4	Per Carton Set (4 Boxes, 20,000 pcs)	9.24±5%

DM137-SSOP Package and Weight (6 Boxes Set)

SSOP28 - 150 - 0.65

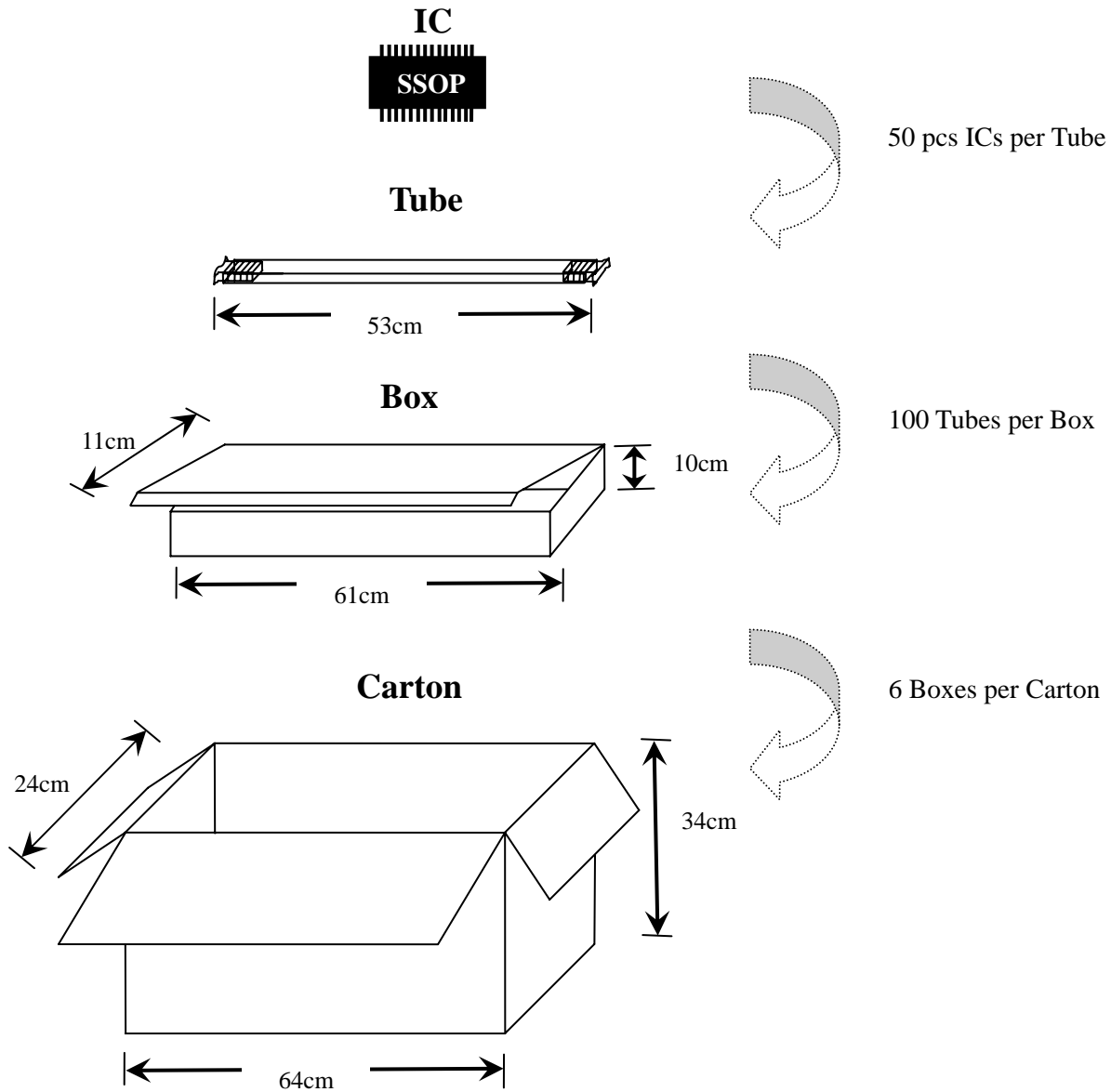

Weight

Item	Description	Weight (Kg)
1	50 pcs DM137-SSOP per Tube	0.016±5%
2	Net Weight of one Box	0.40±5%
3	Net Weight of one Carton	1.44±5%
4	Per Carton Set (6 Boxes, 30,000 pcs)	13.44±5%

DM137-SSOP Package and Weight

SSOP28 - 150 - 0.65

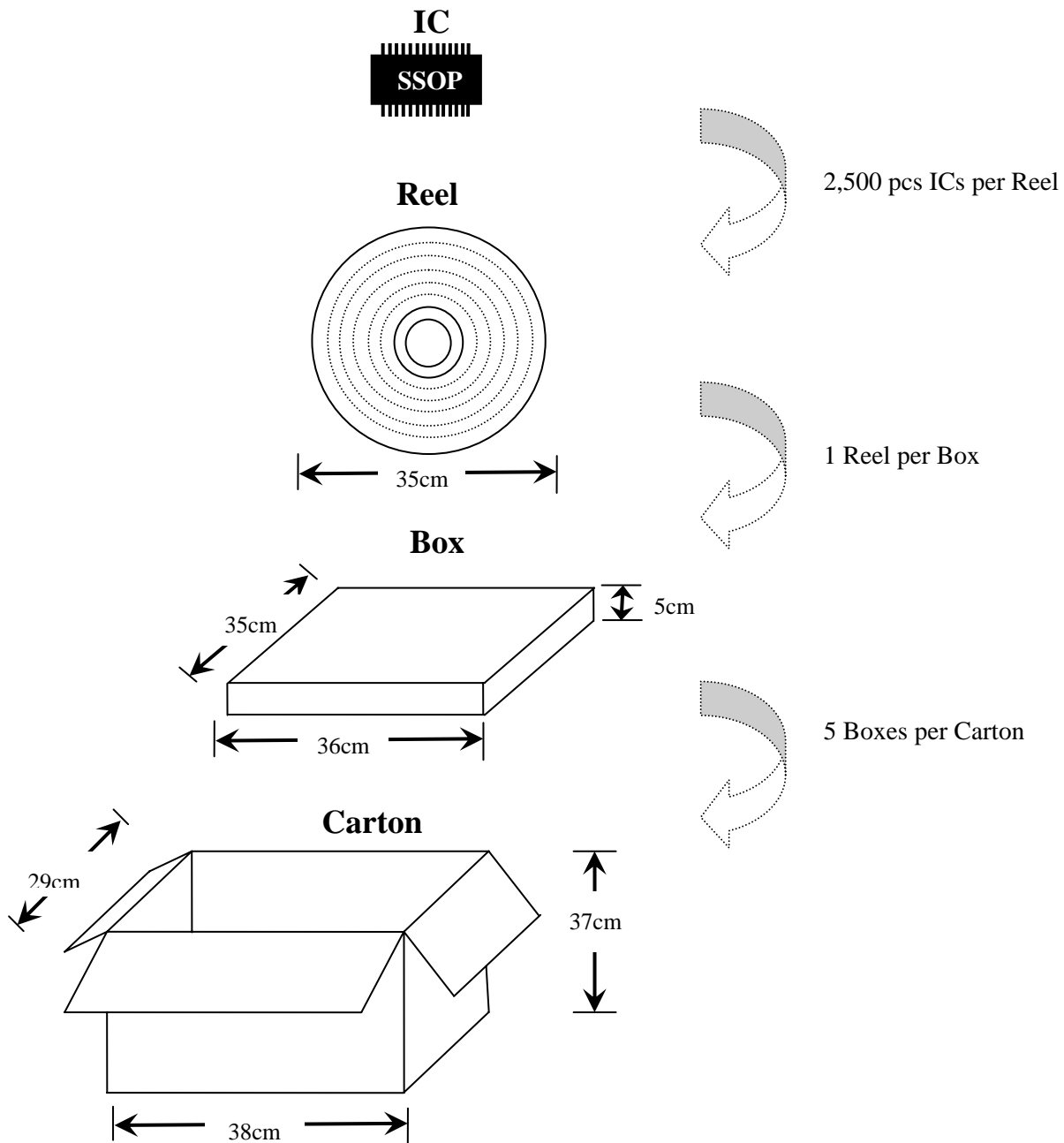

Weight

Item	Description	Weight (Kg)
1	2,500 pcs DM137-SSOP per Reel	0.96±5%
2	Net Weight of one Box	0.24±5%
3	Net Weight of one Carton	0.90±5%
4	Per Carton Set (5 Boxes, 12,500 pcs)	6.9±5%

DM137-HSOP Package and Weight (4 Boxes Set)

HSOP28 - 300 - 1.25

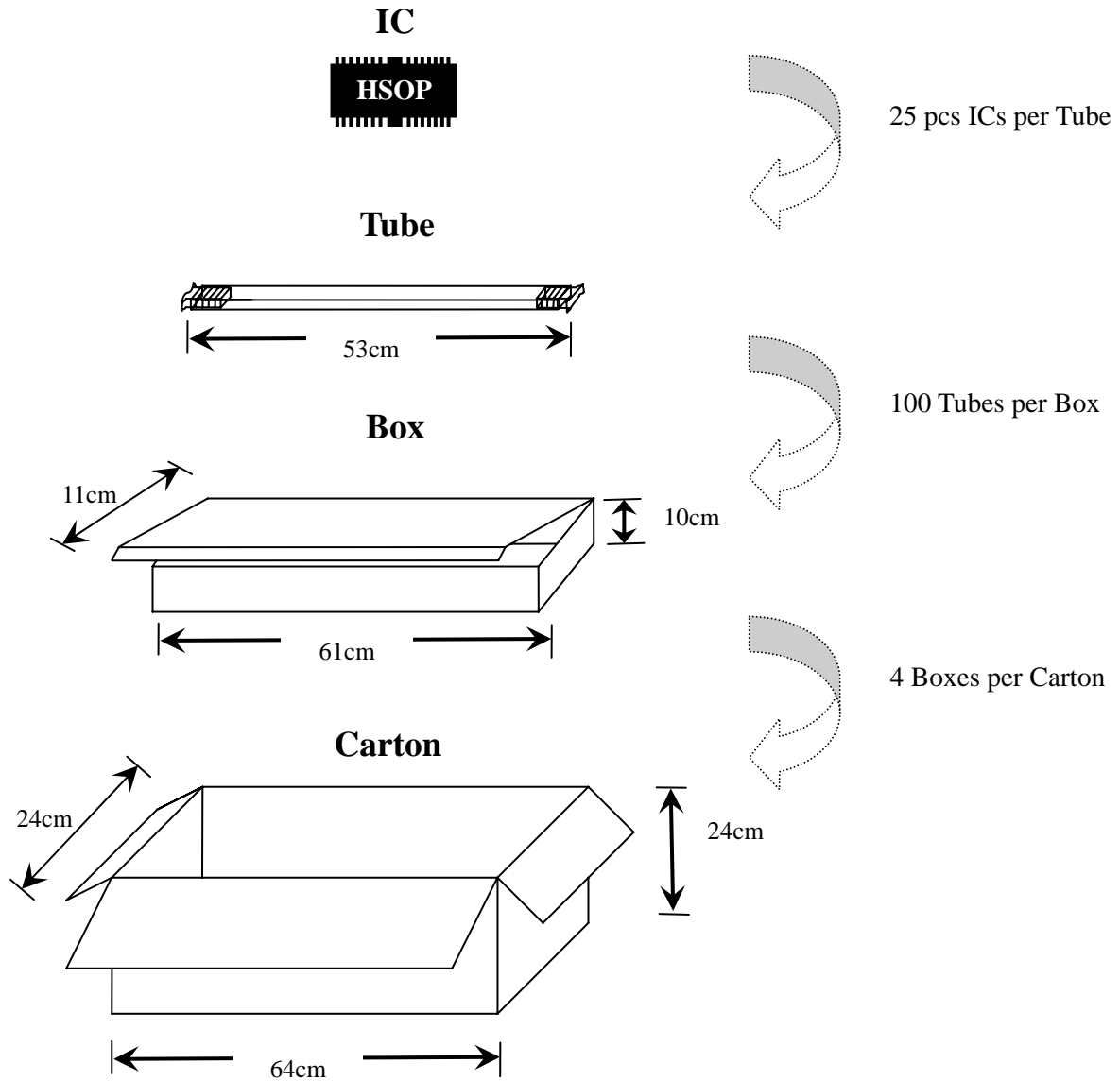

Weight

Item	Description	Weight (Kg)
1	25 pcs DM137-HSOP per Tube	0.03±5%
2	Net Weight of one Box	0.40±5%
3	Net Weight of one Carton	1.24±5%
4	Per Carton Set (4 Boxes, 10,000 pcs)	14.84±5%

DM137-HSOP Package and Weight (6 Boxes Set)

HSOP28 - 300 - 1.25

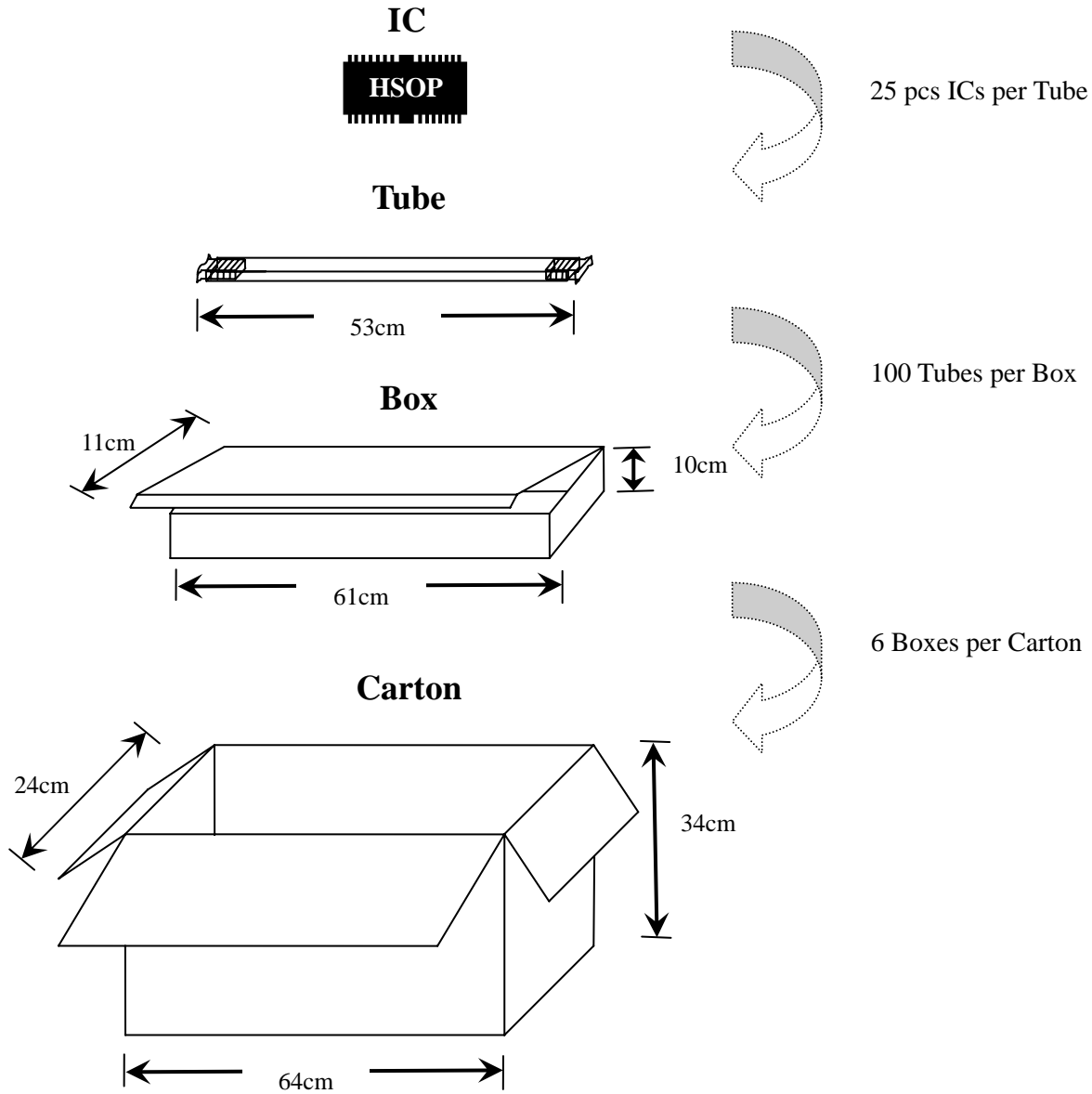

Weight

Item	Description	Weight (Kg)
1	25 pcs DM137-HSOP per Tube	0.03±5%
2	Net Weight of one Box	0.40±5%
3	Net Weight of one Carton	1.44±5%
4	Per Carton Set (6 Boxes, 15,000 pcs)	21.84±5%

DM137-HSOP Package and Weight

HSOP28 - 300 - 1.25

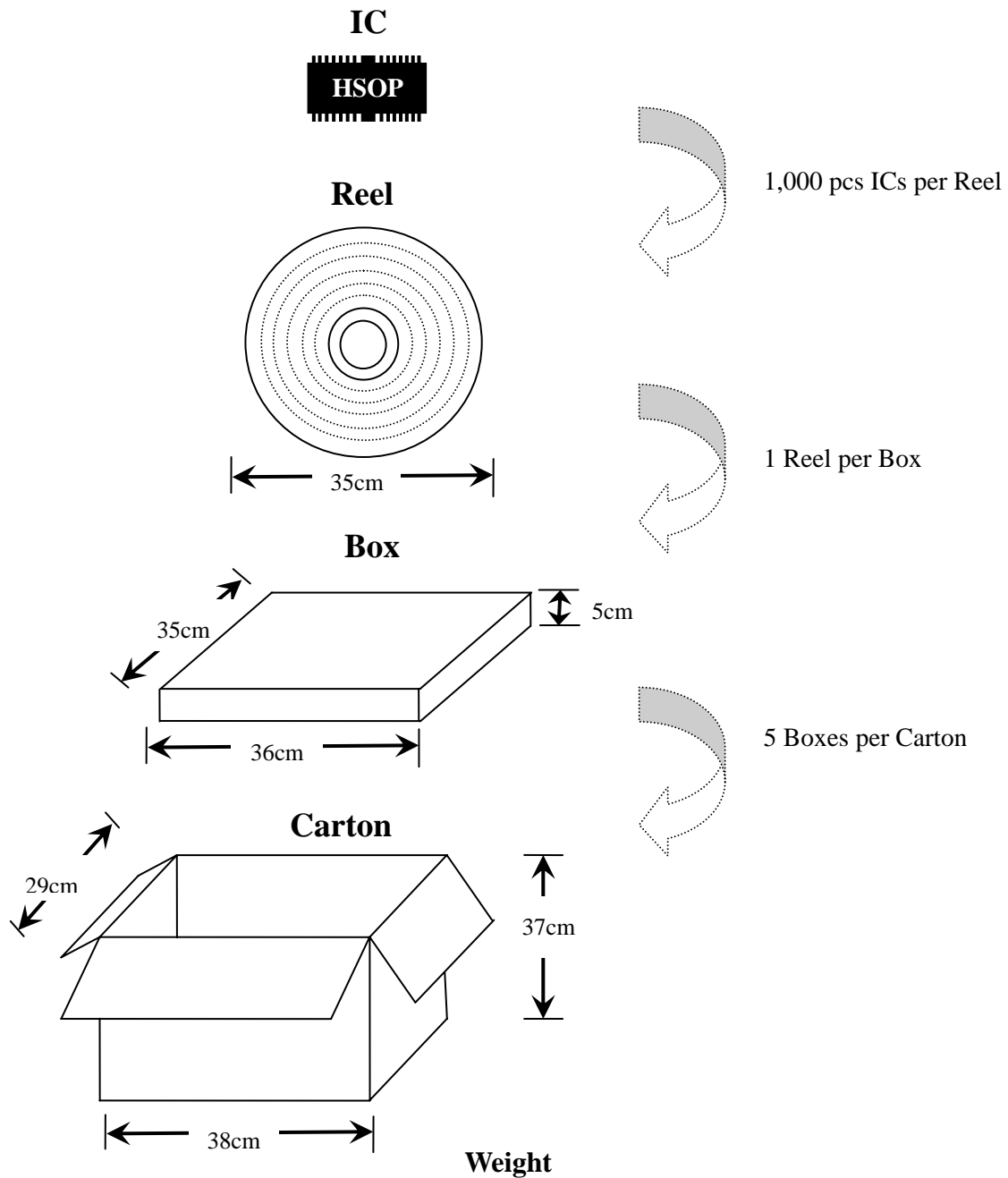

Weight

Item	Description	Weight (Kg)
1	1,000 pcs DM137-HSOP per Reel	1.48±5%
2	Net Weight of one Box	0.24±5%
3	Net Weight of one Carton	0.90±5%
4	Per Carton Set (5 Boxes, 5,000 pcs)	9.5±5%

DM137-QFN Package and Weight

QFN32 - 5×5

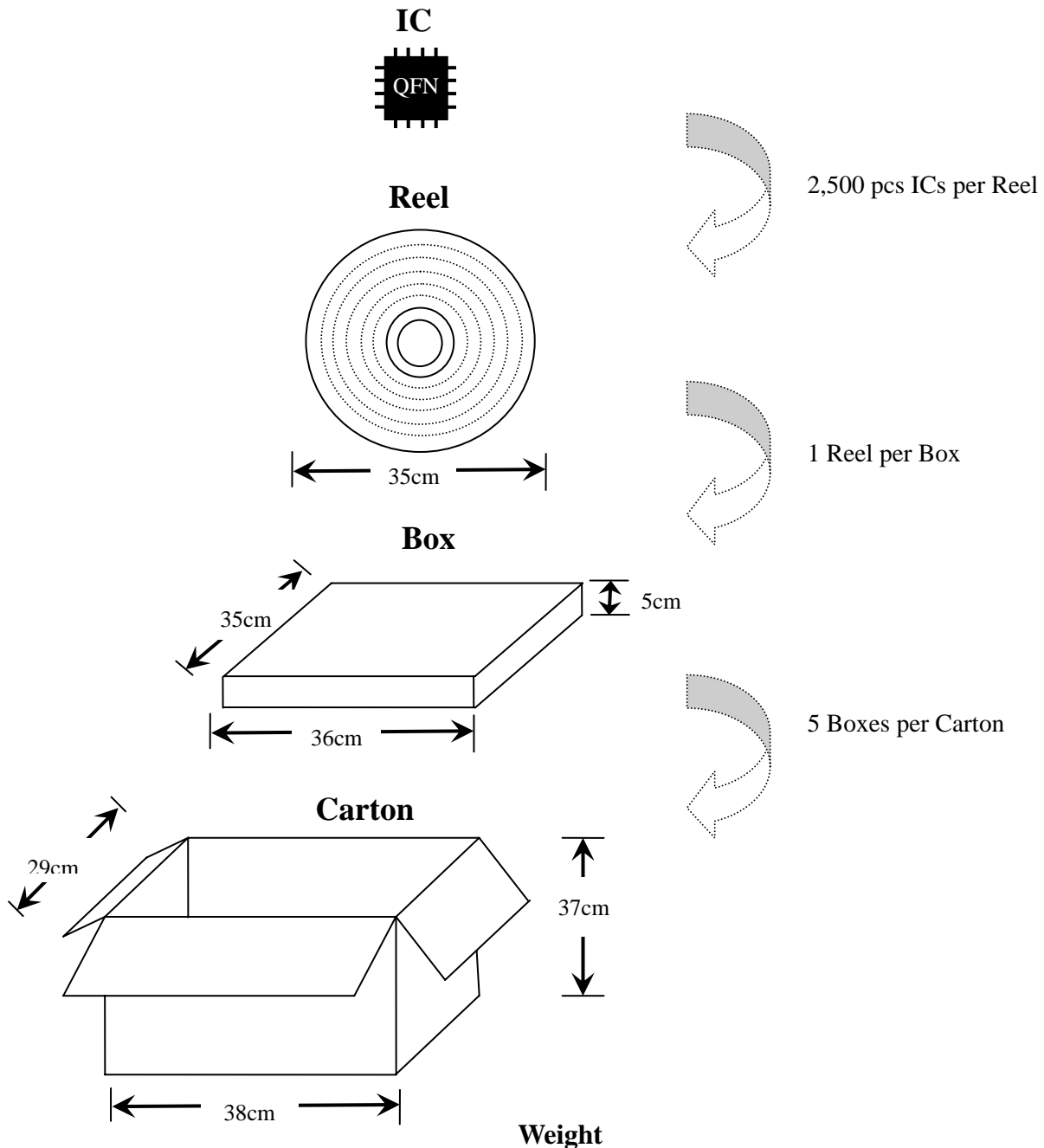

Weight

Item	Description	Weight (Kg)
1	2,500 pcs DM137-QFN per Reel	0.76±5%
2	Net Weight of one Box	0.24±5%
3	Net Weight of one Carton	0.90±5%
4	Per Carton Set (5 Boxes, 12,500 pcs)	5.90±5%



Product Ordering Information

Part Number	Package Type	Number / Weight (typ.)	
		Tube / Tray	Reel (Box included)
DM137-SSOP	SSOP28-150-0.65	50pcs / Tube 0.016kg ± 5%	2,500pcs / Reel 0.96kg ± 5%
DM137-HSOP	HSOP28-300-1.25	25pcs / Tube 0.03kg ± 5%	1,000pcs / Reel 1.48kg ± 5%
DM137-QFN	QFN32-5×5	—	2,500pcs / Reel 0.76kg ± 5%



The products listed herein are designed for ordinary electronic applications, such as electrical appliances, audio-visual equipment, communications devices and so on. Hence, it is advisable that the devices should not be used in medical instruments, surgical implants, aerospace machinery, nuclear power control systems, disaster/crime-prevention equipment and the like. Misusing those products may directly or indirectly endanger human life, or cause injury and property loss.

Silicon Touch Technology, Inc. will not take any responsibilities regarding the misuse of the products mentioned above. Anyone who purchases any products described herein with the above-mentioned intention or with such misused applications should accept full responsibility and indemnify. Silicon Touch Technology, Inc. and its distributors and all their officers and employees shall defend jointly and severally against any and all claims and litigation and all damages, cost and expenses associated with such intention and manipulation.