



Software Protect IC

DM2016

Product Datasheet

SDMC

## Lable of Contents

1、	FEATURES .....	3
2、	BLOCK DIAGRAM .....	3
3、	SUMMARY .....	4
4、	PIN CONNECTION .....	4
5、	PIN DESCRIPTION .....	4
6、	FUNCTION DESCRIPTION.....	5
	6.1 I <sup>2</sup> C .....	5
	6.2 Decryption Function.....	5
	6.3 EEPROM.....	6
	6.4 OTP memory .....	6
7、	ELECTRICAL CHARACTERISTICS .....	6
	7.1 Absolute Maximum Ratings .....	6
	7.2 Operating Conditions .....	6
	7.3 I <sup>2</sup> C Chronograms.....	7
8、	PACKAGE OUTLINE .....	8
	8.1 PACKAGE SOP8.....	8

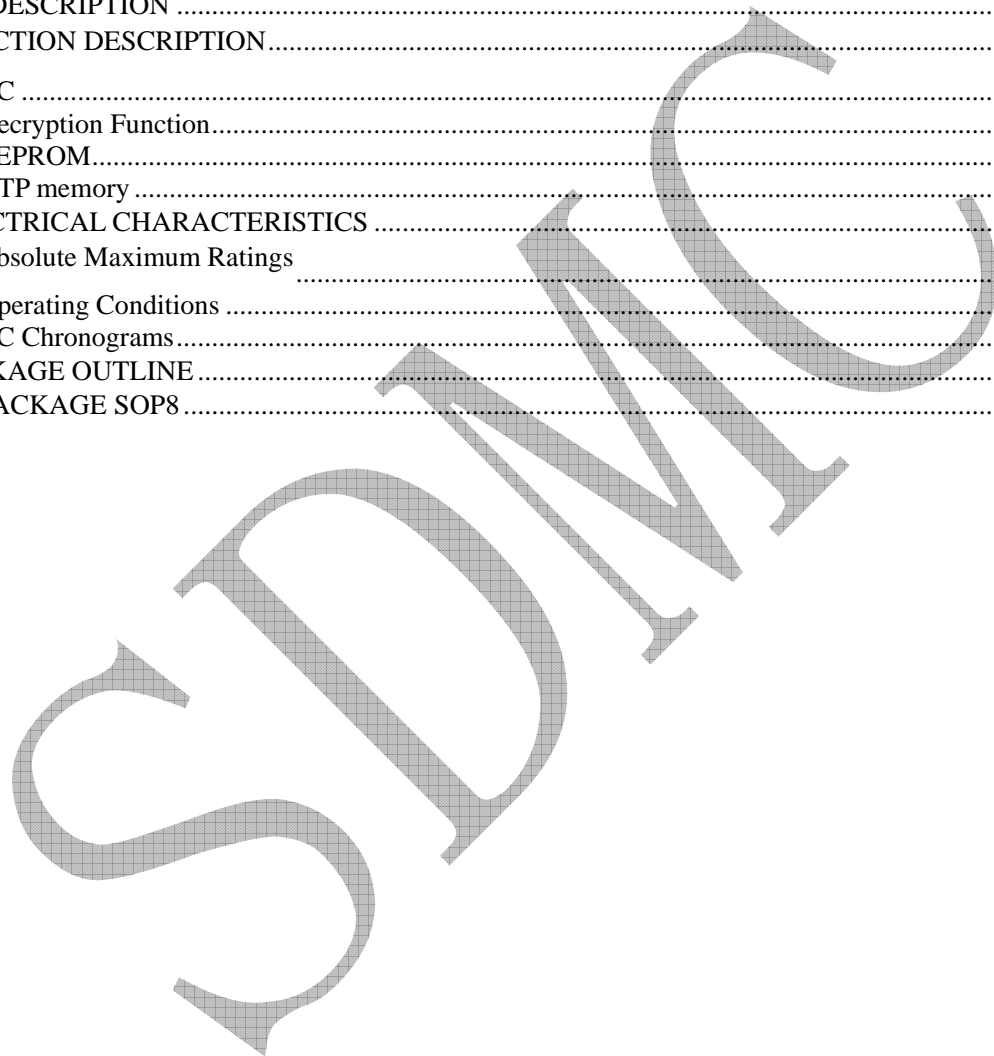

## 1、 FEATURES

- Compliant with I<sup>2</sup>C bus standard
- Support 2 I<sup>2</sup>C address select
- Embedded 128bit OTP memory for key
- Embedded 1024bit EEPROM, support single byte writing and multiple bytes reading
- The interval of EEPROM writing operation is 12ms
- Package type:SOP8

## 2、 BLOCK DIAGRAM

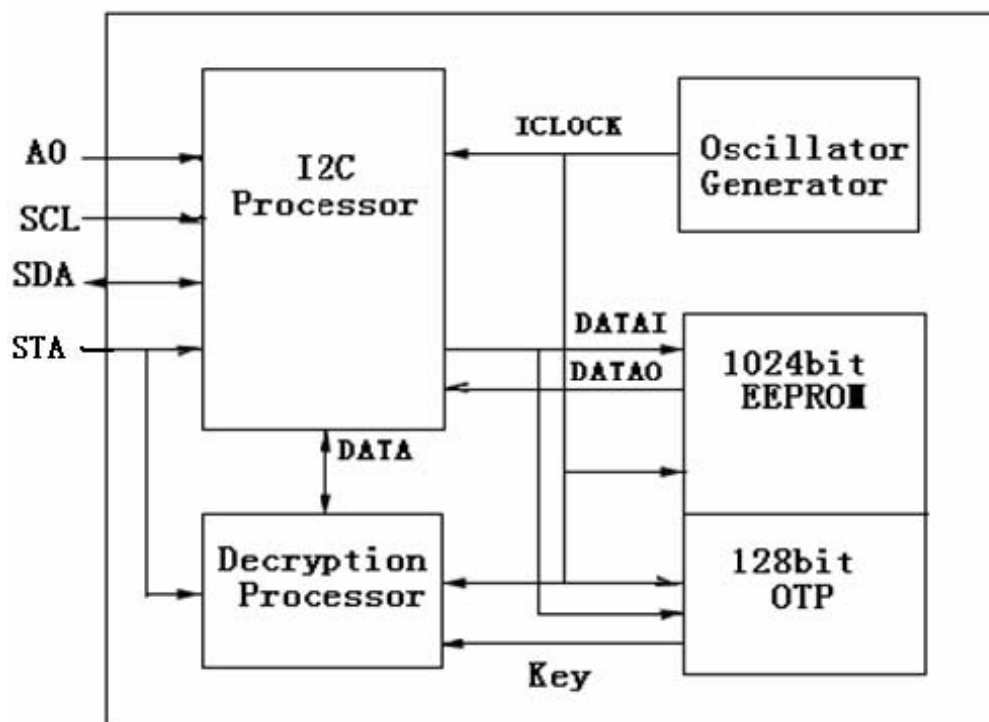

### 3、 SUMMARY

**DM2016** is an encryption chip to prevent from copying. It can effectively protect software design through a decryption arithmetic and the relative secret key of 128 bits. When inputting encrypted code, the decryption will be excuted, and then generates the plain code. The secret keys are stored in 128bit OTP memory.

Besides the decryption function, DM2016 embeds 1024bit EEPROM to store data, all the data transfer is through I<sup>2</sup>C bus.

### 4、 PIN CONNECTION

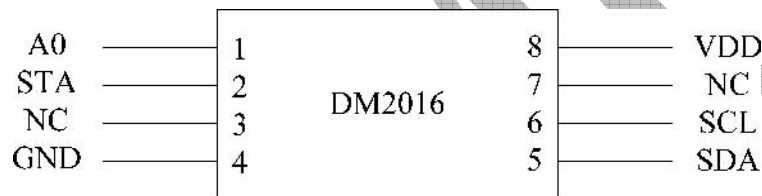

### 5、 PIN DESCRIPTION

Pin Number	Signal Name	I/O	Type	Function
1	A0	I	TTL	I <sup>2</sup> C device address 0
2	STA	I	TTL	Reset, High level is active
3	NC			Not connect
4	GND	/	Power	Power ground
5	SDA	B	TTL	I <sup>2</sup> C data signal
6	SCL	I	TTL	I <sup>2</sup> C clock signal
7	NC			Not connect
8	VCC	/	Power	Power supply 3.3V

**Note:** STA Signal only accept resistance capacitance reset, The time of STA pulse with is two milliseconds; and high level must be attained 2V.( The STA pin not support GPIO reset)

## 6、 FUNCTION DESCRIPTION

### 6.1 I<sup>2</sup>C

**DM2016** has an I<sup>2</sup>C slave device interface, there are two I<sup>2</sup>C device addresses can be selected through controlling the external port. The high 6-bit of I2C address is "101000", so the I<sup>2</sup>C device address can be selected with 0xA0, 0xA2.

I<sup>2</sup>C data address space assignment:

Address	Description
0x00-0x7F	EEPROM
0x80-0x8F	128 bit secret key
0x90-0x97	64 bit plain code and encrypted code

The most signification byte of 128 bit secret key is stored in address "0x80"; The least signification byte of 128 bit secret key is stored in address "0x8F".

The most signification byte of 64 bit plain code or encrypted code is stored in address "0x90", the least signification byte of 64 bit plain code or encrypted code is stored in address "0x97". When reading, the data is plain code. When writing, the data is encrypted code.

### 6.2 Decryption Function

**DM2016** is a security chip to prevent from copying. It can effectively protect software design through a decryption arithmetic and the relative 128 bit secret key. The 128 bit secret keys are stored in OTP memory.

The authentication process of **DM2016** is as below:

A group of 64bit random data generated by program acts as plain code. Program executes the encryption arithmetic by utilizing the plain code and the same secret key in 128 bit OTP memory, and generates a group of encrypted code. Then program sends the encrypted code to DM2016 through I<sup>2</sup>C interface. DM2016 executes the decryption arithmetic with 128 bit secret key and 64 bit encrypted code, then generates a group of 64 bit plain code. Program reads back the plain code through I<sup>2</sup>C interface, then compares the plain code with the original plain code (64bit random data). If the two values are equal, it will declare that the authentication pass and the program will continue to execute. Otherwise, the program will exit.

## 6.3 EEPROM

**DM2016** embeds 1024 bit EEPROM for users to store data. The access of EEPROM is through I<sup>2</sup>C interface.

## 6.4 OTP memory

**DM2016** embeds 128 bit OTP memory to store secret key. The access of OTP is also through I<sup>2</sup>C interface. OTP can only be written one time and can not be read.

# 7、 ELECTRICAL CHARACTERISTICS

## 7.1 Absolute Maximum Ratings

Symbol	Parameter	Value	Unit
Vs	Power Supply	-0.5 to 3.6	V
Vp	Signal Supply Voltage	-0.3 to 5.5	V
Tstg	Storage Temperature	0-125	°C
Iout	Output Current	8	mA

## 7.2 Operating Conditions

Symbol	Parameter	Min	Type	Max	Unit
VDD	Power Supply	3.0	3.3	3.6	V
V <sub>IL</sub>	Input Low Voltage	-0.3		0.8	V
V <sub>IH</sub>	Input High Voltage	2.0		5.5	V <sub>IL</sub>
V <sub>OL</sub>	Output Low Voltage			0.4	V
V <sub>OH</sub>	Output High Voltage	2.4			uA
I <sub>OZ</sub>	Tristate Output Leakage Current	-10		+10	uA
I <sub>L</sub>	Input Leakage Current	-10		+10	uA
I <sub>OL</sub>	Output Low Current @ V <sub>OL</sub> =0.4V	2.2	3.4	4.0	mA
I <sub>OH</sub>	Output High Current @ V <sub>OL</sub> =2.4V	2.89	4.78	6.63	mA
T <sub>J</sub>	Junction temperature	0	25	70	°C

## 7.3 I<sup>2</sup>C Chronograms

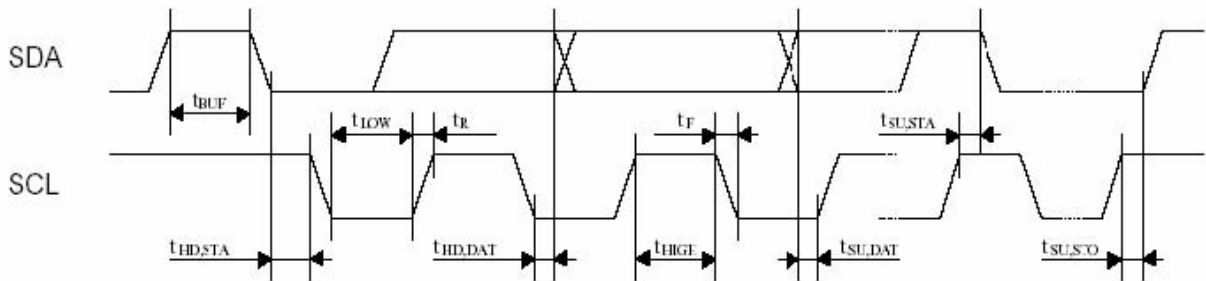

### I<sup>2</sup>C Chronograms

#### I<sup>2</sup>C Characteristics

Parameter	Symbol	Min	Max	Unit
SCL frequency	fSCL		400	KHz
Bus free time between stop and start	tBUF	1.3		μ s
Hold time start condition	tHD,STA	0.9		μ s
SCL low period	tLOW	1.3		μ s
SCL high period	tHIGH	0.9		μ s
Setup time before a repeated start	tSU,STA	0.9		μ s
Data hold time	tHD,DAT	0	0.9	μ s
Data setup time	tSU,DAT	100		ns
Rise time for both SDA and SCL signals	tR	20	300	ns
Fall time for both SDA and SCL signals	tF	20	300	ns
Setup time before a stop condition	tSU,STO	0.9		μ s
Capacitive load for each bus line	Cb		400	pF

## 8、 PACKAGE OUTLINE

### 8.1 PACKAGE SOP8

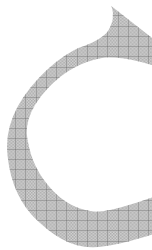
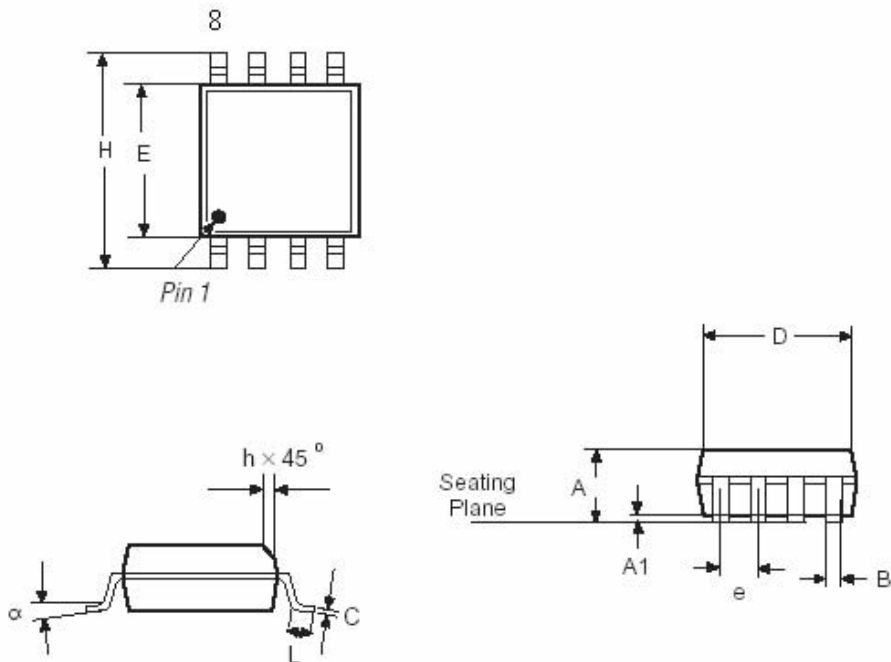

**Package Outline Figure Reference**

Symbol	Millimeters		
	Min.	Nom.	Max.
A	—	1.35	1.75
A1	—	0.10	0.25
B	—	0.33	0.51
C	—	0.19	0.25
D	—	4.80	5.00
E	—	3.80	4.00
e	1.27 BSC		
H	—	5.80	6.20
h	—	0.25	0.50
L	—	0.40	1.27
$\alpha$	—	0°C	8°C