

DM240128-21

*240x128DOTS 1/128Duty 1/12Bias
Yellow-Green or Blue mode STN Transflective

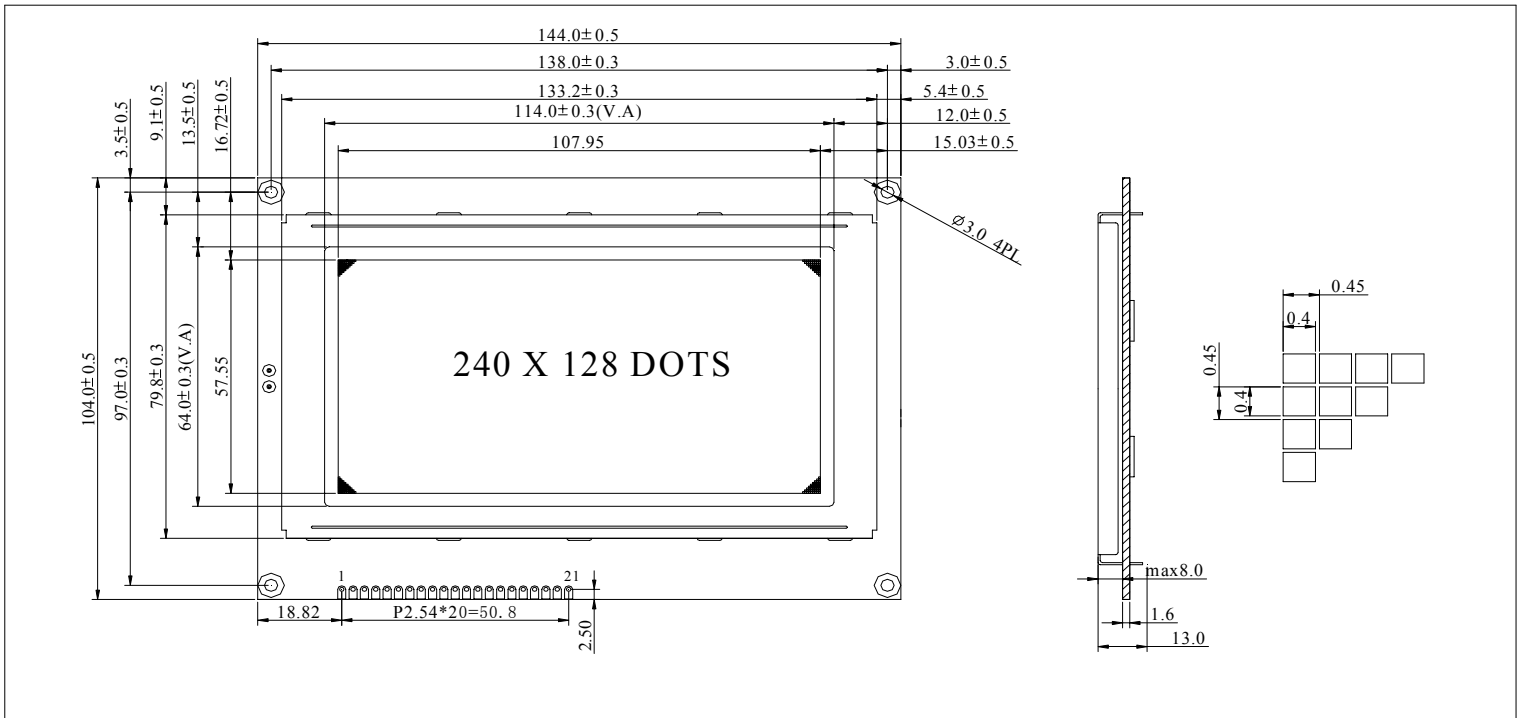

ABSOLUTE MAXIMUM RATINGS

Item	Symbol	Min.	Max.	Unit
Supply Voltage(Logic)	Vdd - Vss	-0.3	5.5	V
Supply Voltage(LCD)	Vdd - V0	-0.3	20	V
Input Voltage	Vi	-0.3	Vdd + 0.3	V
Operating Temp.	Topr	-20	70	°C
Storage Temp.	Tstg	-30	80	°C

MECHANICAL DATA

Item	Max.	Unit
Module Size (W X H X T)	144.0 X 104.0 X 14.0	mm
Viewing Area(W X H)	114.0 X 64.0	mm
Dot Pitch(W X H)	0.45 X 0.45	mm
Dot Size(W X H)	0.40 X 0.40	mm
View Angle	6 or 12 O'Clock	

ELECTRICAL CHARACTERISTICS (Vdd=5V±0.25V)

Item	Symbol	Test Condition	Min.	Typ.	Max.	Unit
Input High Voltage	Vih	--	2.0	--	Vdd	V
Input Low Voltage	Vil	--	-0.3	--	0.8	V
Output High Voltage	Voh	Ioh=-0.2mA	2.4	--	Vdd	V
Output Low Voltage	Vol	Iol=-1.6mA	0	--	0.4	V
Supply Current	Idd	Vdd=5.0V	--	20.0	25.0	mA
LCD Driving Voltage	Vdd - V0	Ta=25 °C	--	18.0	--	V

PIN CONNECTIONS

Pin	Symbol	Level	Function
1	FG	--	Frame ground
2	VSS	0V	Power GND
3	VDD	+5V	Power supply for logic
4	V0	--	Operation voltage for LCD
5	/WR	L	Write signal, active"L"
6	/RD	L	Read signal, active"L"
7	/CE	L	Chip enable signal, active"L"
8	C/D	H/L	L: Data H: Instruction code
9	RST	L	Reset signal, active"L"
10	DB0	H/L	Data bus line
11	DB1	H/L	
12	DB2	H/L	
13	DB3	H/L	
14	DB4	H/L	
15	DB5	H/L	
16	DB6	H/L	
17	DB7	H/L	
18	FS	H/L	Font selection L: 8 X 8, H:6 X 8
19	BLA	+5V	Power supply for LED backlight
20	BLK	0V	
21	NC		

BLOCK DIAGRAM

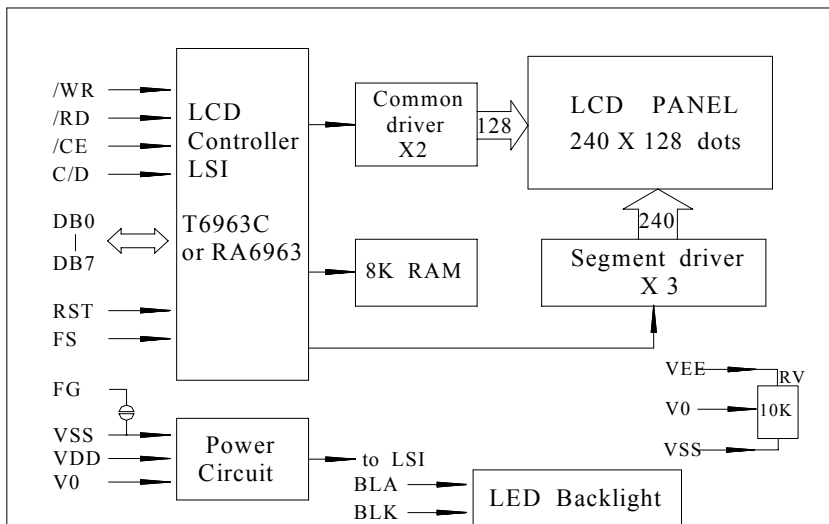

LCD Color	Backlight
Yellow Green	LED/Yellow Green/4.2V (≤500mA)
Blue	LED/White /3.1V (≤200mA)