



DM54141/DM74141 BCD to Decimal Decoders/Drivers

General Description

The DM54141/DM74141 is a BCD-to-decimal decoder designed to drive cold-cathode indicator tubes.

Full decoding is provided for all possible input states. For binary inputs 10 through 15, all the outputs are off. Therefore the DM54141/DM74141, combined with a minimum of external circuitry, can use these invalid codes in blanking leading- and/or trailing-edge zeros in a display.

Input clamp diodes are also provided to clamp negative-voltage transitions in order to minimize transmission-line effects.

Features

- Drive cold-cathode, numeric indicator tubes directly
- Fully decoded inputs
- Low leakage current 50 μ A @ 55V
- Low power dissipation 55 mW typical

Connection Diagram

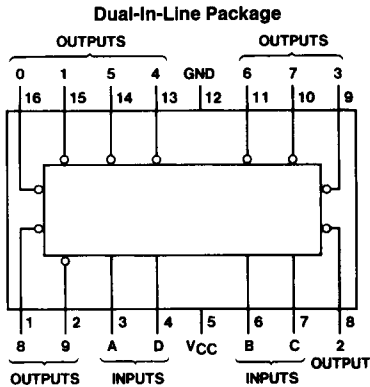

TL/F/6543-1

Order Number DM54141J or DM74141N
See NS Package Number J16A or N16A

Function Table

Inputs				Output On*
D	C	B	A	
L	L	L	L	0
L	L	L	H	1
L	L	H	L	2
L	L	H	H	3
L	H	L	L	4
L	H	L	H	5
L	H	H	L	6
L	H	H	H	7
H	L	L	L	8
H	L	L	H	9
(Over Range)				
H	L	H	L	None
H	L	H	H	None
H	H	L	L	None
H	H	L	H	None
H	H	H	L	None
H	H	H	H	None

H = High Level, L = Low Level

* All other outputs are off

Absolute Maximum Ratings (Note)

Specifications for Military/Aerospace products are not contained in this datasheet. Refer to the associated reliability electrical test specifications document.

Supply Voltage	7V
Input Voltage	5.5V
Operating Free Air Temperature Range	
DM54	-55°C to +125°C
DM74	0°C to +70°C
Storage Temperature Range	-65°C to +150°C

Note: The "Absolute Maximum Ratings" are those values beyond which the safety of the device cannot be guaranteed. The device should not be operated at these limits. The parametric values defined in the "Electrical Characteristics" table are not guaranteed at the absolute maximum ratings. The "Recommended Operating Conditions" table will define the conditions for actual device operation.

Recommended Operating Conditions

Symbol	Parameter	DM54141			DM74141			Units
		Min	Nom	Max	Min	Nom	Max	
V _{CC}	Supply Voltage	4.5	5	5.5	4.75	5	5.25	V
V _{IH}	High Level Input Voltage	2			2			V
V _{IL}	Low Level Input Voltage			0.8			0.8	V
I _{OL}	Low Level Output Current			7			7	mA
T _A	Free Air Operating Temperature	-55		125	0		70	°C

Electrical Characteristics over recommended operating free air temperature range (unless otherwise noted)

Symbol	Parameter	Conditions	Min	Typ (Note 1)	Max	Units
V _I	Input Clamp Voltage	V _{CC} = Min, I _I = -12 mA			-1.5	V
V _{OH}	High Level Output Voltage	V _{CC} = Min, I _{OH} = 0.5 mA	60			V
I _{OH}	Off-State Reverse Current for Input Counts 10-15	V _{CC} = Min V _O = 30V			5	μA
		T _A = -55°C			15	
I _{OH}	Off-State Reverse Current for Input Counts 0-9	V _{CC} = Min V _O = 55V			50	μA
V _{OL}	Low Level Output Voltage	V _{CC} = Min, I _{OL} = Max V _{IL} = Max, V _{IH} = Min			2.5	V
		T _A = -55°C to +70°C T _A = 125°C			3	
I _I	Input Current @ Max Input Voltage	V _{CC} = Max, V _I = 5.5V			1	mA
I _{IH}	High Level Input Current	V _{CC} = Max V _I = 2.4V			40	μA
		A Input B, C, D Inputs			80	
I _{IL}	Low Level Input Current	V _{CC} = Max V _I = 0.4V			-1.6	mA
		A Input B, C, D Inputs			-3.2	
I _{CC}	Supply Current	V _{CC} = Max (Note 2)		11	25	mA

Note 1: All typicals are at V_{CC} = 5V, T_A = 25°C.

Note 2: I_{CC} is measured with all inputs grounded and all outputs open.

Logic Diagram

54141/74141

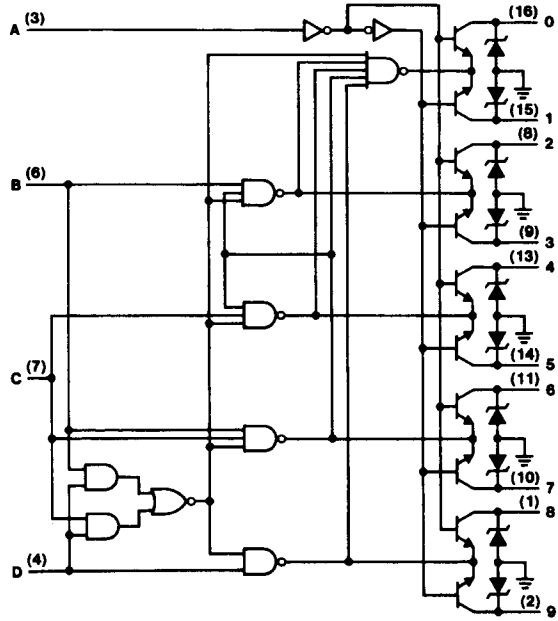

TL/F/6543-2