



DM54253/DM74253 TRI-STATE® Dual 1 of 4 Line Data Selectors/Multiplexers

General Description

This device is a TRI-STATE version of the very popular DM54153 (DM7214) data selectors/multiplexers. It contains full on-chip decoding to select the desired data input. The DM54/74253 is a dual, four-line multiplexer that has common select lines which therefore select the same input line of both multiplexers. However, the two outputs can be individually controlled by means of the separate enable lines; which, when taken to a high logic level, places the output in the high-impedance TRI-STATE condition. The data at the output of the DM54/74253 is true.

- Typical propagation delay 13.5 ns
- Typical power dissipation 170 mW
- Strobe / enable override

Absolute Maximum Ratings (Note 1)

Supply Voltage	7V
Input Voltage	5.5V
Storage Temperature Range	- 65°C to 150°C

Note 1: The "Absolute Maximum Ratings" are those values beyond which the safety of the device can not be guaranteed. The device should not be operated at these limits. The parametric values defined in the "Electrical Characteristics" table are not guaranteed at the absolute maximum ratings. The "Recommended Operating Conditions" table will define the conditions for actual device operation.

Features

- TRI-STATE pin equivalents to popular 54/74 TTL devices
DM7214/8214 — 54153/74153

Connection Diagrams

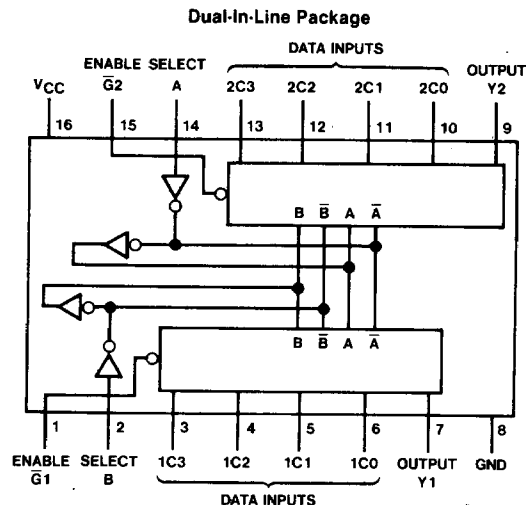

TL/F/6568-1

Recommended Operating Conditions

Symbol	Parameter	DM54253			DM74253			Units
		Min	Nom	Max	Min	Nom	Max	
V_{CC}	Supply Voltage	4.5	5	5.5	4.75	5	5.25	V
V_{IH}	High Level Input Voltage	2			2			V
V_{IL}	Low Level Input Voltage			0.8			0.8	V
I_{OH}	High Level Output Current			-2			-5.2	mA
I_{OL}	Low Level Output Current			16			16	mA
T_A	Free Air Operating Temperature	-55		125	0		70	°C

Electrical Characteristics over recommended operating free air temperature (unless otherwise noted)

Symbol	Parameter	Conditions	Min	Typ (Note 1)	Max	Units	
V_I	Input Clamp Voltage	$V_{CC} = \text{Min}, I_I = -12 \text{ mA}$			-1.5	V	
V_{OH}	High Level Output Voltage	$V_{CC} = \text{Min}, I_{OH} = \text{Max}$ $V_{IL} = \text{Max}, V_{IH} = \text{Min}$	2.4			V	
V_{OL}	Low Level Output Voltage	$V_{CC} = \text{Min}, I_{OL} = \text{Max}$ $V_{IH} = \text{Min}, V_{IL} = \text{Max}$			0.4	V	
I_I	Input Current @ Max Input Voltage	$V_{CC} = \text{Max}, V_I = 5.5 \text{ V}$			1	mA	
I_{IH}	High Level Input Current	$V_{CC} = \text{Max}, V_I = 2.4 \text{ V}$			40	μA	
I_{IL}	Low Level Input Current	$V_{CC} = \text{Max}, V_I = 0.4 \text{ V}$			-1.6	mA	
I_{OZH}	Off-State Output Current with High Level Output Voltage Applied	$V_{CC} = \text{Max}, V_O = 2.4 \text{ V}$ $V_{IH} = \text{Min}, V_{IL} = \text{Max}$			40	μA	
I_{OZL}	Off-State Output Current with Low Level Output Voltage Applied	$V_{CC} = \text{Max}, V_O = 0.4 \text{ V}$ $V_{IH} = \text{Min}, V_{IL} = \text{Max}$			-40	μA	
I_{OS}	Short Circuit Output Current	$V_{CC} = \text{Max}$ (Note 2)	DM54	-18		-55	mA
			DM74	-18		-55	
I_{CC}	Supply Current	$V_{CC} = \text{Max}$ (Note 3)	DM54		34	56	mA
			DM74		34	65	

Note 1: All typicals are at $V_{CC} = 5 \text{ V}, T_A = 25^\circ\text{C}$.

Note 2: Not more than one output should be shorted at a time.

Note 3: I_{CC} is measured with all inputs grounded and outputs open.

Switching Characteristics at $V_{CC} = 5V$ and $T_A = 25^\circ C$ (See Section 1 for Test Waveforms and Output Load)

Parameter	From (Input) To (Output)	$R_L = 400\Omega$						Units
		$C_L = 5\text{ pF}$			$C_L = 50\text{ pF}$			
		Min	Typ	Max	Min	Typ	Max	
t_{PLH} Propagation Delay Time Low to High Level Output	Data to Output					15	23	ns
t_{PHL} Propagation Delay Time High to Low Level Output	Data to Output					12	18	ns
t_{PLH} Propagation Delay Time Low to High Level Output	Select to Output					20	34	ns
t_{PHL} Propagation Delay Time High to Low Level Output	Select to Output					20	34	ns
t_{PZH} Output Enable Time to High Level Output	Enable to Q					12	18	ns
t_{PZL} Output Enable Time to Low Level Output	Enable to Q					14	21	ns
t_{PHZ} Output Disable Time from High Level Output	Enable to Q		5	10				ns
t_{PLZ} Output Disable Time from Low Level Output	Enable to Q		15	23				ns

Function Table

Select Inputs		Data Inputs				Enable	Output
B	A	C0	C1	C2	C3	\bar{G}	Y
X	X	X	X	X	X	H	Hi-Z
L	L	L	X	X	X	L	L
L	L	L	H	X	X	L	H
L	H	X	L	X	X	L	L
L	H	X	H	X	X	L	H
H	L	X	X	L	X	L	L
H	L	X	X	H	X	L	H
H	H	X	X	X	L	L	L
H	H	X	X	X	H	L	H

L = Low Logic Level
 H = High Logic Level
 X = Either Low or High Logic Level
 Hi-Z = High Impedance (Off) State

Logic Diagram

54/74253

