

DM74AS1036A Quad 2-Input NOR Driver

General Description

These devices contain four independent drivers, each of which performs the logic NOR function. Each driver has increased output drive capability, allowing the driving of high capacitive loads.

Features

- Switching specifications at 50 pF
- Switching specification guaranteed over full temperature and V_{CC} range
- Advanced oxide-isolated, ion-implanted Schottky TTL process

Connection Diagram

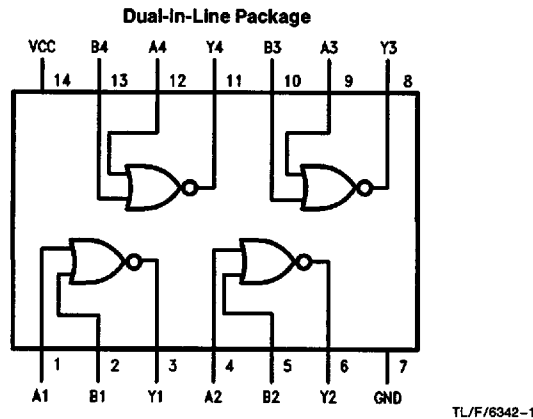

Order Number DM74AS1036AM or DM74AS1036AN
See NS Package Number M14A or N14A

Function Table

$$Y = \overline{A + B}$$

Inputs		Output
A	B	Y
L	L	H
X	H	L
H	X	L

H = High Level
L = Low Level
X = Don't Care

Absolute Maximum Ratings

Supply Voltage	7V
Input Voltage	7V
Operating Free Air Temperature	0°C to +70°C
Storage Temperature Range	-65°C to +150°C
Typical θ_{JA}	
N Package	76.0°C/W
M Package	106.0°C/W

Note: The "Absolute Maximum Ratings" are those values beyond which the safety of the device cannot be guaranteed. The device should not be operated at these limits. The parametric values defined in the "Electrical Characteristics" table are not guaranteed at the absolute maximum ratings. The "Recommended Operating Conditions" table will define the conditions for actual device operation.

Recommended Operating Conditions

Symbol	Parameter	Min	Nom	Max	Units
V_{CC}	Supply Voltage	4.5	5	5.5	V
V_{IH}	High Level Input Voltage	2			V
V_{IL}	Low Level Input Voltage			0.8	V
I_{OH}	High Level Output Current			-48	mA
I_{OL}	Low Level Output Current			48	mA
T_A	Operating Free Air Temperature Range	0		70	°C

Electrical Characteristics over recommended operating free air temperature range

Symbol	Parameter	Conditions	Min	Typ (Note 2)	Max	Units
V_{IK}	Input Clamp Voltage	$V_{CC} = 4.5V, I_I = -18\text{ mA}$			-1.2	V
V_{OH}	High Level Output Voltage	$I_{OH} = -2\text{ mA}, V_{CC} = 4.5V\text{ to }5.5V$	$V_{CC} - 2$			V
		$I_{OH} = -3\text{ mA}, V_{CC} = 4.5V$	2.4	3.2		
		$I_{OH} = \text{Max}, V_{CC} = 4.5V$	2			
V_{OL}	Low Level Output Voltage	$V_{CC} = 4.5V, I_{OL} = \text{Max}, V_{IH} = 2V$		0.35	0.5	V
I_I	Input Current at Maximum Input Voltage	$V_{CC} = 5.5V, V_I = 7V$			100	μA
I_{IH}	High Level Input Current	$V_{CC} = 5.5V, V_I = 2.7V$			20	μA
I_{IL}	Low Level Input Current	$V_{CC} = 5.5V, V_I = 0.4V$			-500	μA
I_O	Output Drive Current	$V_{CC} = 5.5V, V_O = 2.25V$	-50	-135	-200	mA
I_{CCH}	Supply Current with Outputs High	$V_{CC} = 5.5V$		4.7	7	mA
I_{CCL}	Supply Current with Outputs Low	$V_{CC} = 5.5V$		15.3	23	mA

Switching Characteristics over recommended operating free air temperature range (Note 1)

Symbol	Parameter	Conditions (Note 1)	Min	Max	Units
t_{PLH}	Propagation Delay Time, Low to High Level Output	$V_{CC} = 4.5V\text{ to }5.5V$ $R_L = 500\Omega$ $C_L = 50\text{ pF}$	1	4.3	ns
t_{PHL}	Propagation Delay Time, High to Low Level Output		1	4.3	ns

Note 1: See Section 5 for test waveforms and output load.

Note 2: Typical values are measured at $V_{CC} = 5V$ and $T_A = 25^\circ\text{C}$.

Physical Dimensions inches (millimeters)

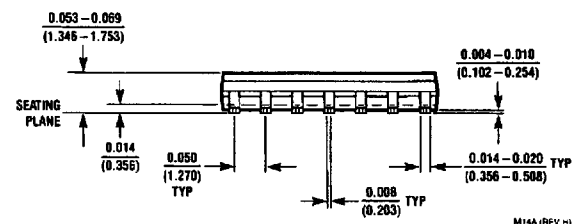
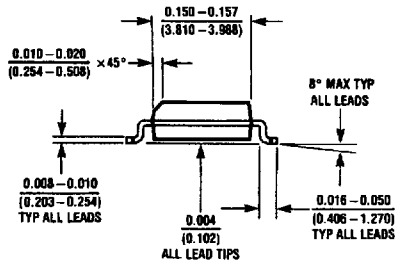
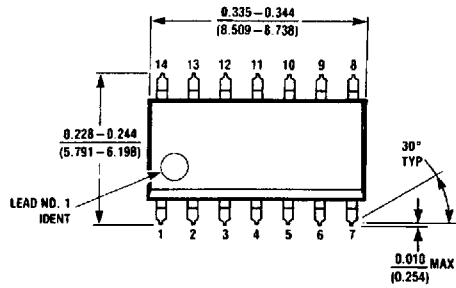

M14A (REV H)

S.O. Package (M)
Order Number DM74AS1036AM
NS Package Number M14A

Physical Dimensions inches (millimeters) (Continued)

Lit. # 102874

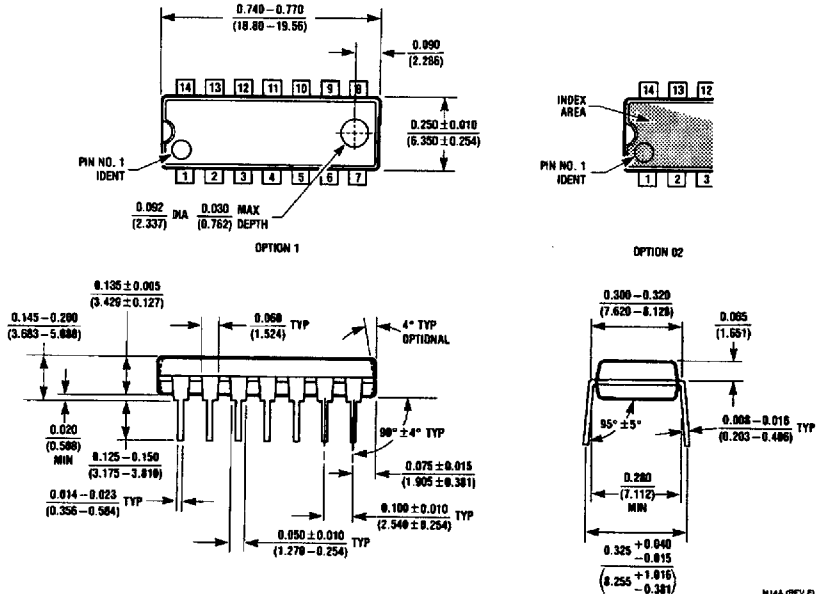

Molded Dual-In-Line Package (N)
Order Number DM74AS1036AN
NS Package Number N14A

LIFE SUPPORT POLICY

NATIONAL'S PRODUCTS ARE NOT AUTHORIZED FOR USE AS CRITICAL COMPONENTS IN LIFE SUPPORT DEVICES OR SYSTEMS WITHOUT THE EXPRESS WRITTEN APPROVAL OF THE PRESIDENT OF NATIONAL SEMICONDUCTOR CORPORATION. As used herein:

1. Life support devices or systems are devices or systems which, (a) are intended for surgical implant into the body, or (b) support or sustain life, and whose failure to perform, when properly used in accordance with instructions for use provided in the labeling, can be reasonably expected to result in a significant injury to the user.
2. A critical component is any component of a life support device or system whose failure to perform can be reasonably expected to cause the failure of the life support device or system, or to affect its safety or effectiveness.

National Semiconductor Corporation
 1111 West Bardin Road
 Arlington, TX 76017
 Tel: 1(800) 272-9959
 Fax: 1(800) 737-7018
<http://www.national.com>

National Semiconductor Europe
 Fax: +49 (0) 180-530 85 86
 Email: europe.support@nsc.com
 Deutsch Tel: +49 (0) 180-530 85 85
 English Tel: +49 (0) 180-532 78 32
 Français Tel: +49 (0) 180-532 93 58
 Italiano Tel: +49 (0) 180-534 16 80

National Semiconductor Hong Kong Ltd.
 13th Floor, Straight Block,
 Ocean Centre, 5 Canton Rd.
 Tsimshatsui, Kowloon
 Hong Kong
 Tel: (852) 2737-1600
 Fax: (852) 2736-9960

National Semiconductor Japan Ltd.
 Tel: 81-043-299-2308
 Fax: 81-043-299-2408

National does not assume any responsibility for use of any circuitry described, no circuit patent licenses are implied and National reserves the right at any time without notice to change said circuitry and specifications.