

DM74LS197 Presettable Binary Counters

General Description

The 'LS197 ripple counter contains divide-by-two and divide-by-eight sections which can be combined to form a modulo-16 binary counter. State changes are initiated by the falling edge of the clock. The 'LS197 has a Master Reset (\overline{MR}) input which overrides all other inputs and asynchronously forces all outputs LOW. A Parallel Load input (\overline{PL}) overrides clocked operations and asynchronously loads the data on the Parallel Data inputs (P_n) into the flip-flops. This preset feature makes the circuit usable as a programmable counter. The circuit can also be used as a 4-bit

latch, loading data from the Parallel Data inputs when \overline{PL} is LOW and storing the data when \overline{PL} is HIGH. For detail specifications and functional description, please refer to the 'LS196 data sheet.

Features

- High counting rates—Typically 70 MHz
- Asynchronous preset
- Asynchronous master reset

Connection Diagram

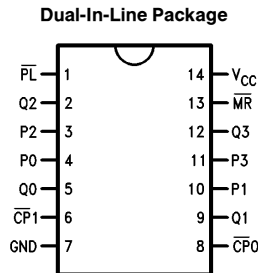

TL/F/10180-1

Order Number DM74LS197M or DM74LS197N
See NS Package Number M14A or N14A

Pin Names	Description
$\overline{CP0}$	$\div 2$ Section Clock Input (Active Falling Edge)
$\overline{CP1}$	$\div 8$ Section Clock Input (Active Falling Edge)
\overline{MR}	Asynchronous Master Reset Input (Active LOW)
P0–P3	Parallel Data Inputs
\overline{PL}	Asynchronous Parallel Load Input (Active LOW)
Q0	$\div 2$ Section Output*
Q1–Q3	$\div 8$ Section Outputs

Mode Select Table

Inputs			Response
\overline{MR}	\overline{PL}	\overline{CP}	
L	X	X	Qn Forced LOW
H	L	X	$P_n \rightarrow Q_n$
H	H		Count Up

H = HIGH Voltage Level
L = LOW Voltage Level
X = Immaterial

*Q0 output is guaranteed to drive the full rated fan-out plus the $\overline{CP1}$ input.

Absolute Maximum Ratings (Note)

If Military/Aerospace specified devices are required, please contact the National Semiconductor Sales Office/Distributors for availability and specifications.

Supply Voltage	7V
Input Voltage	7V
Operating Free Air Temperature Range	0°C to +70°C
DM74LS	
Storage Temperature Range	-65°C to +150°C

Note: The "Absolute Maximum Ratings" are those values beyond which the safety of the device cannot be guaranteed. The device should not be operated at these limits. The parametric values defined in the "Electrical Characteristics" table are not guaranteed at the absolute maximum ratings. The "Recommended Operating Conditions" table will define the conditions for actual device operation.

Recommended Operating Conditions

Symbol	Parameter	DM74LS197			Units
		Min	Nom	Max	
V _{CC}	Supply Voltage	4.75	5	5.25	V
V _{IH}	High Level Input Voltage	2			V
V _{IL}	Low Level Input Voltage			0.8	V
I _{OH}	High Level Output Current			-0.4	mA
I _{OL}	Low Level Output Current			8	mA
T _A	Free Air Operating Temperature	0		70	°C

Electrical Characteristics over recommended operating free air temperature range (unless otherwise noted)

Symbol	Parameter	Conditions	Min	Typ (Note 1)	Max	Units
V _I	Input Clamp Voltage	V _{CC} = Min, I _I = -18 mA			-1.5	V
V _{OH}	High Level Output Voltage	V _{CC} = Min, I _{OH} = Max, V _{IL} = Max	2.7	3.4		V
V _{OL}	Low Level Output Voltage	V _{CC} = Min, I _{OL} = Max, V _{IH} = Min		0.35	0.5	V
		I _{OL} = 4 mA, V _{CC} = Min		0.25	0.4	
I _I	Input Current @ Max Input Voltage	V _{CC} = Max, V _I = 7V			0.1	mA
I _{IH}	High Level Input Current	V _{CC} = Max, V _I = 2.7V			20	μA
I _{IL}	Low Level Input Current	V _{CC} = Max, V _I = 0.4V			-0.4	mA
I _{OS}	Short Circuit Output Current	V _{CC} = Max (Note 2)	-20		-100	mA
I _{CC}	Supply Current	V _{CC} = Max			27	mA

Note 1: All typicals are at V_{CC} = 5V, T_A = 25°C.

Note 2: Not more than one output should be shorted at a time, and the duration should not exceed one second.

Switching Characteristics

$V_{CC} = +5.0V, T_A = +25^\circ C$

Symbol	Parameter	$R_L = 2\text{ k}\Omega$ $C_L = 15\text{ pF}$		Units
		Min	Max	
f_{MAX}	Max CLK Frequency	55		MHz
t_{PLH} t_{PHL}	Propagation Delay $\overline{CP0}$ to Q0		15 15	ns
t_{PLH} t_{PHL}	Propagation Delay $\overline{CP1}$ to Q2		34 34	ns
t_{PLH} t_{PHL}	Propagation Delay P2 to Q2		27 44	ns
t_{PLH} t_{PHL}	Propagation Delay \overline{PL} to Q2		39 45	ns
t_{PLH} t_{PHL}	Propagation Delay $\overline{CP1}$ to Q1		15 17	ns
t_{PLH} t_{PHL}	Propagation Delay $\overline{CP1}$ to Q3		55 63	ns
t_{PHL}	Propagation Delay \overline{MR} to Q3		42	ns

Logic Diagram

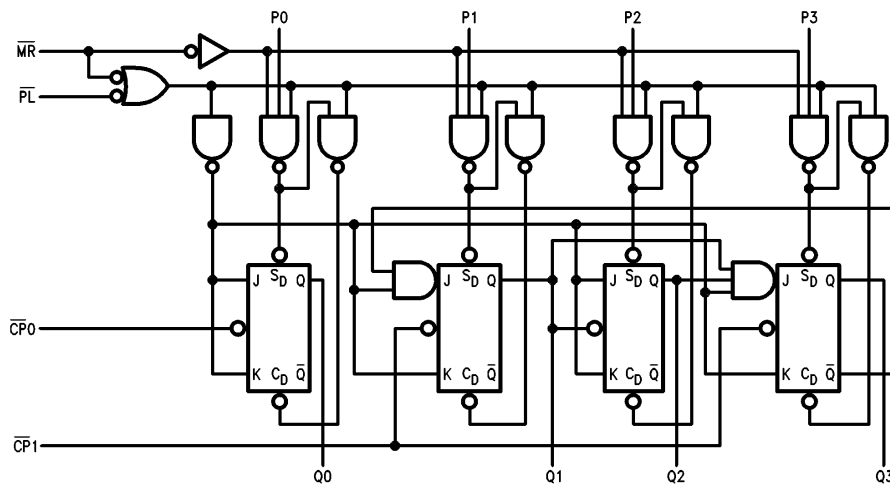

TL/F/10180-4

Logic Symbol

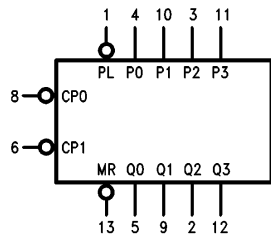

V_{CC} = Pin 14
GND = Pin 7

TL/F/10180-2

÷ 16 State Diagram

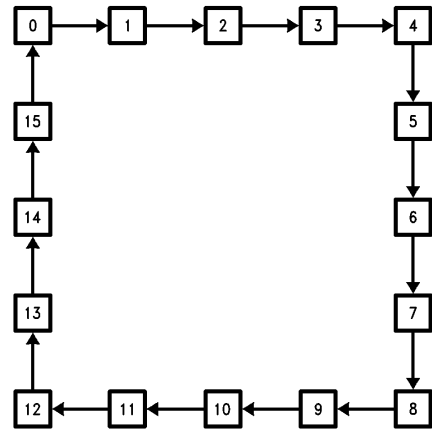

TL/F/10180-3

Physical Dimensions inches (millimeters)

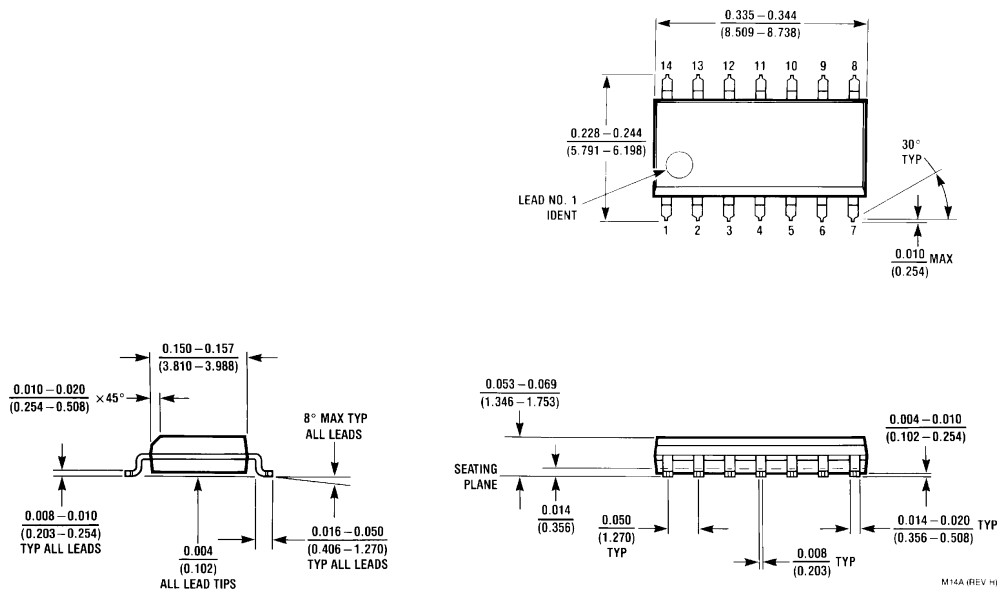

14-Lead Small Outline Molded Package (M)
Order Number DM74LS197M
NS Package Number M14A

M14A (REV HI)

Physical Dimensions inches (millimeters) (Continued)

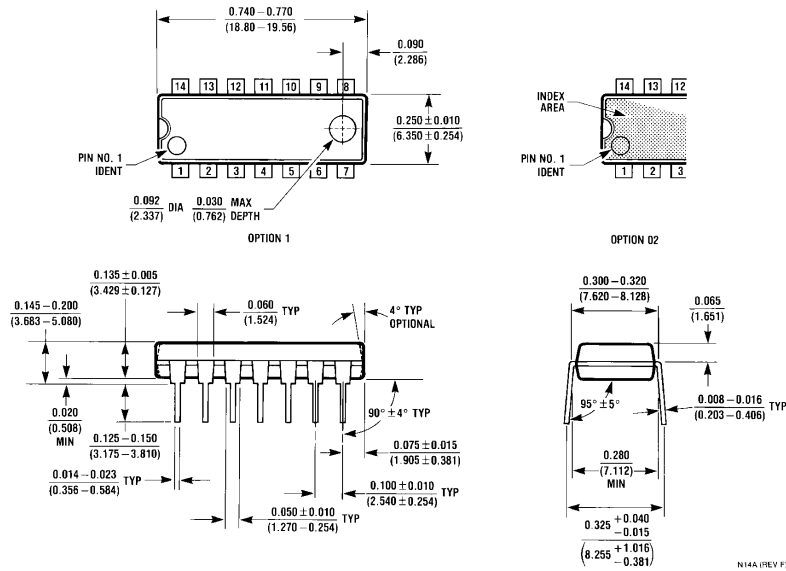

14-Lead Molded Dual-In-Line Package (N)
Order Number DM74LS197N
NS Package Number N14A

LIFE SUPPORT POLICY

NATIONAL'S PRODUCTS ARE NOT AUTHORIZED FOR USE AS CRITICAL COMPONENTS IN LIFE SUPPORT DEVICES OR SYSTEMS WITHOUT THE EXPRESS WRITTEN APPROVAL OF THE PRESIDENT OF NATIONAL SEMICONDUCTOR CORPORATION. As used herein:

1. Life support devices or systems are devices or systems which, (a) are intended for surgical implant into the body, or (b) support or sustain life, and whose failure to perform, when properly used in accordance with instructions for use provided in the labeling, can be reasonably expected to result in a significant injury to the user.
2. A critical component is any component of a life support device or system whose failure to perform can be reasonably expected to cause the failure of the life support device or system, or to affect its safety or effectiveness.



National Semiconductor Corporation
 1111 West Bardin Road
 Arlington, TX 76017
 Tel: 1(800) 272-9959
 Fax: 1(800) 737-7018

National Semiconductor Europe
 Fax: (+49) 0-180-530 85 86
 Email: cnjwge@tevm2.nsc.com
 Deutsch Tel: (+49) 0-180-530 85 85
 English Tel: (+49) 0-180-532 78 32
 Français Tel: (+49) 0-180-532 93 58
 Italiano Tel: (+49) 0-180-534 16 80

National Semiconductor Hong Kong Ltd.
 19th Floor, Straight Block,
 Ocean Centre, 5 Canton Rd.
 Tsimshatsui, Kowloon
 Hong Kong
 Tel: (852) 2737-1600
 Fax: (852) 2736-9960

National Semiconductor Japan Ltd.
 Tel: 81-043-299-2309
 Fax: 81-043-299-2408

National does not assume any responsibility for use of any circuitry described, no circuit patent licenses are implied and National reserves the right at any time without notice to change said circuitry and specifications.