



DM54S257/DM74S257, DM54S258/DM74S258 TRI-STATE® Quad 1 of 2 Data Selectors/Multiplexers

General Description

These Schottky-clamped high-performance multiplexers feature TRI-STATE outputs that can interface directly with data lines of bus-organized systems. With all but one of the common outputs disabled (at a high impedance state), the low impedance of the single enabled output will drive the bus line to a high or low logic level. To minimize the possibility that two outputs will attempt to take a common bus to opposite logic levels, the output enable circuitry is designed such that the output disable times are shorter than the output enable times.

This TRI-STATE output feature means that n-bit (paralleled) data selectors with up to 258 sources can be implemented for data buses. It also permits the use of standard TTL registers for data retention throughout the system.

Features

- TRI-STATE versions S157, S158, with same pin-outs
- Schottky-clamped for significant improvement in A-C performance
- Provides bus interface from multiple sources in high-performance systems
- Average propagation delay from data input
 - S257 4.8 ns
 - S258 4 ns
- Typical power dissipation
 - S257 320 mW
 - S258 280 mW

Connection Diagrams

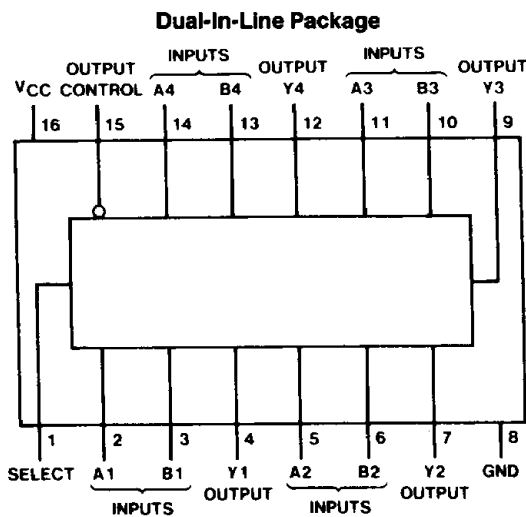

TL/F/6482-1

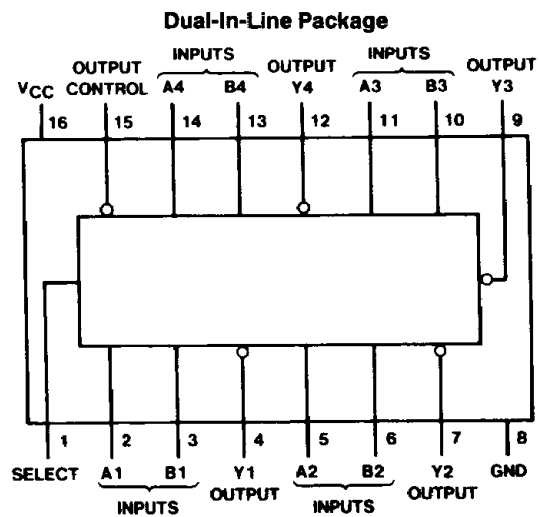

TL/F/6482-2

Order Number **DM54S257J, DM54S258J, DM54S257W, DM74S257N or DM74S258N**
See NS Package Number J16A, N16E or W16A

Function Table

Output Control	Inputs			Output Y	
	Select	A	B	S257	S258
H	X	X	X	Z	Z
L	L	L	X	L	H
L	L	H	X	H	L
L	H	X	L	L	H
L	H	X	H	H	L

H = High Level, L = Low Level, X = Don't Care
Z = High Impedance (off)

Absolute Maximum Ratings (Note)

If Military/Aerospace specified devices are required, please contact the National Semiconductor Sales Office/Distributors for availability and specifications.

Supply Voltage	7V
Input Voltage	5.5V
Operating Free Air Temperature Range	
DM54S	−55°C to +125°C
DM74S	0°C to +70°C
Storage Temperature Range	−65°C to +150°C

Note: The "Absolute Maximum Ratings" are those values beyond which the safety of the device cannot be guaranteed. The device should not be operated at these limits. The parametric values defined in the "Electrical Characteristics" table are not guaranteed at the absolute maximum ratings. The "Recommended Operating Conditions" table will define the conditions for actual device operation.

Recommended Operating Conditions

Symbol	Parameter	DM54S257			DM74S257			Units
		Min	Nom	Max	Min	Nom	Max	
V _{CC}	Supply Voltage	4.5	5	5.5	4.75	5	5.25	V
V _{IH}	High Level Input Voltage	2			2			V
V _{IL}	Low Level Input Voltage			0.8			0.8	V
I _{OH}	High Level Output Current			−2			−6.5	mA
I _{OL}	Low Level Output Current			20			20	mA
T _A	Free Air Operating Temperature	−55		125	0		70	°C

'S257 Electrical Characteristics

over recommended operating free air temperature (unless otherwise noted)

Symbol	Parameter	Conditions	Min	Typ (Note 1)	Max	Units
V _I	Input Clamp Voltage	V _{CC} = Min, I _I = −18 mA			−1.2	V
V _{OH}	High Level Output Voltage	V _{CC} = Min, I _{OH} = Max V _{IL} = Max, V _{IH} = Min	DM54 2.4	3.4		V
V _{OL}	Low Level Output Voltage	V _{CC} = Min, I _{OL} = Max V _{IH} = Min, V _{IL} = Max			0.5	V
I _I	Input Current @ Max Input Voltage	V _{CC} = Max, V _I = 5.5V			1	mA
I _{IH}	High Level Input Current	V _{CC} = Max V _I = 2.7V	Select		100	μA
I _{IL}	Low Level Input Current	V _{CC} = Max, V _I = 0.5V	Select		−4	mA
I _{OZH}	Off-State Output Current with High Level Output Voltage Applied	V _{CC} = Max, V _O = 2.4V V _{IH} = Min, V _{IL} = Max			50	μA
I _{OZL}	Off-State Output Current with Low Level Output Voltage Applied	V _{CC} = Max, V _O = 0.5V V _{IH} = Min, V _{IL} = Max			−50	μA
I _{OS}	Short Circuit Output Current	V _{CC} = Max (Note 2)	DM54 −40		−100	mA
I _{CCH}	Supply Current with Outputs High	V _{CC} = Max (Note 3)		44	68	mA
I _{CCL}	Supply Current with Outputs Low	V _{CC} = Max (Note 3)		60	93	mA
I _{CCZ}	Supply Current with Outputs Disabled	V _{CC} = Max (Note 3)		64	99	mA

Note 1: All typicals are at V_{CC} = 5V, T_A = 25°C.

Note 2: Not more than one output should be shorted at a time, and the duration should not exceed one second.

Note 3: I_{CC} is measured with all outputs open and all possible inputs grounded, while achieving the stated output conditions.

'S257 Switching Characteristicsat $V_{CC} = 5V$ and $T_A = 25^\circ C$ (See Section 1 for Test Waveforms and Output Load)

Symbol	Parameter	From (Input) To (Output)	$R_L = 280\Omega$				Units
			$C_L = 15\text{ pF}$		$C_L = 50\text{ pF}$		
			Min	Max	Min	Max	
t_{PLH}	Propagation Delay Time Low to High Level Output	Data to Output		7.5		11	ns
t_{PHL}	Propagation Delay Time High to Low Level Output	Data to Output		6.5		10	ns
t_{PLH}	Propagation Delay Time Low to High Level Output	Select to Output		15		16	ns
t_{PHL}	Propagation Delay Time High to Low Level Output	Select to Output		15		16	ns
t_{PZH}	Output Enable Time to High Level Output	Output Control to Y		19.5		23	ns
t_{PZL}	Output Enable Time to Low Level Output	Output Control to Y		21		24	ns
t_{PHZ}	Output Disable Time to High Level Output (Note 1)	Output Control to Y		8.5			ns
t_{PLZ}	Output Disable Time to Low Level Output (Note 1)	Output Control to Y		14			ns

Note 1: $C_L = 5\text{ pF}$.**Recommended Operating Conditions**

Symbol	Parameter	DM54S258			DM74S258			Units
		Min	Nom	Max	Min	Nom	Max	
V_{CC}	Supply Voltage	4.5	5	5.5	4.75	5	5.25	V
V_{IH}	High Level Input Voltage	2			2			V
V_{IL}	Low Level Input Voltage			0.8			0.8	V
I_{OH}	High Level Output Current			-2			-6.5	mA
I_{OL}	Low Level Output Current			20			20	mA
T_A	Free Air Operating Temperature	-55		125	0		70	$^\circ C$

'S258 Electrical Characteristics

over recommended operating free air temperature (unless otherwise noted)

Symbol	Parameter	Conditions	Min	Typ (Note 1)	Max	Units
V_I	Input Clamp Voltage	$V_{CC} = \text{Min}, I_I = -18\text{ mA}$			-1.2	V
V_{OH}	High Level Output Voltage	$V_{CC} = \text{Min}, I_{OH} = \text{Max}$ $V_{IL} = \text{Max}, V_{IH} = \text{Min}$	DM54	2.4	3.4	V
			DM74	2.4	3.2	
V_{OL}	Low Level Output Voltage	$V_{CC} = \text{Min}, I_{OL} = \text{Max}$ $V_{IH} = \text{Min}, V_{IL} = \text{Max}$			0.5	V
I_I	Input Current @ Max Input Voltage	$V_{CC} = \text{Max}, V_I = 5.5V$			1	mA
I_{IH}	High Level Input Current	$V_{CC} = \text{Max},$ $V_I = 2.7V$	Select		100	μA
			Other		50	
I_{IL}	Low Level Input Current	$V_{CC} = \text{Max},$ $V_I = 0.5V$	Select		-4	mA
			Other		-2	

'S258 Electrical Characteristics

over recommended operating free air temperature (unless otherwise noted) (Continued)

Symbol	Parameter	Conditions	Min	Typ (Note 1)	Max	Units
I _{OZH}	Off-State Output Current with High Level Output Voltage Applied	V _{CC} = Max, V _O = 2.4V V _{IH} = Min, V _{IL} = Max			50	μA
I _{OZL}	Off-State Output Current with Low Level Output Voltage Applied	V _{CC} = Max, V _O = 0.5V V _{IH} = Min, V _{IL} = Max			-50	μA
I _{OS}	Short Circuit Output Current	V _{CC} = Max (Note 2)	DM54	-40	-100	mA
			DM74	-40	-100	
I _{CCH}	Supply Current with Outputs High	V _{CC} = Max (Note 3)		36	56	mA
I _{CCL}	Supply Current with Outputs Low	V _{CC} = Max (Note 3)		52	81	mA
I _{CCZ}	Supply Current with Outputs Disabled	V _{CC} = Max (Note 3)		56	87	mA

Note 1: All typicals are at V_{CC} = 5V, T_A = 25°C.**Note 2:** Not more than one output should be shorted at a time, and the duration should not exceed one second.**Note 3:** I_{CC} is measured with all outputs open and all possible inputs grounded, while achieving the stated output conditions.**'S258 Switching Characteristics**at V_{CC} = 5V and T_A = 25°C (See Section 1 for Test Waveforms and Output Load)

Symbol	Parameter	From (Input) To (Output)	R _L = 280Ω				Units
			C _L = 15 pF		C _L = 50 pF		
			Min	Max	Min	Max	
t _{PLH}	Propagation Delay Time Low to High Level Output	Data to Output		6		9	ns
t _{PHL}	Propagation Delay Time High to Low Level Output	Data to Output		6		9	ns
t _{PLH}	Propagation Delay Time Low to High Level Output	Select to Output		12		15	ns
t _{PHL}	Propagation Delay Time High to Low Level Output	Select to Output		12		15	ns
t _{PZH}	Output Enable Time to High Level Output	Output Control to Y		19.5		23	ns
t _{PZL}	Output Enable Time to Low Level Output	Output Control to Y		21		24	ns
t _{PHZ}	Output Disable Time to High Level Output (Note 1)	Output Control to Y		8.5			ns
t _{PLZ}	Output Disable Time to Low Level Output (Note 1)	Output Control to Y		14			ns

Note 1: C_L = 5 pF.

Logic Diagrams

S257

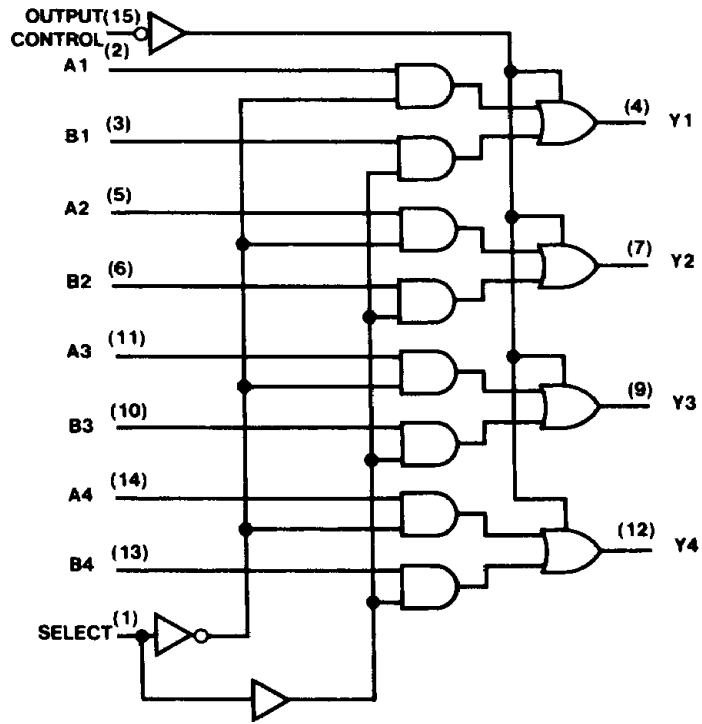

TL/F/6482-3

S258

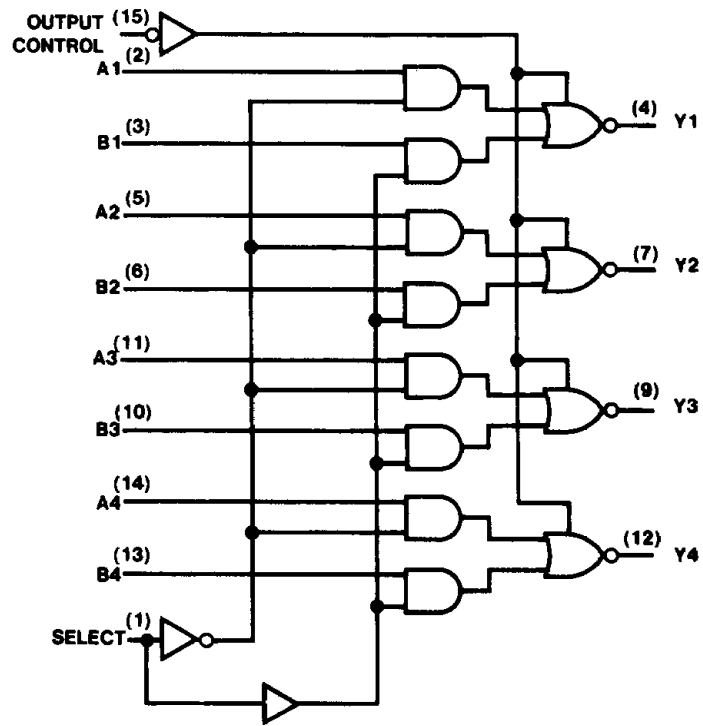

TL/F/6482-4