



DM35820HR

DM9820HR

DM8820HR

DM7820HR

Versatile High Speed Digital I/O

User's Manual

BDM-610010036 Rev. D



RTD Embedded Technologies, Inc.

103 Innovation Boulevard
State College, PA 16803 USA
Telephone: 814-234-8087
Fax: 814-234-5218

www.rtd.com

sales@rtd.com
techsupport@rtd.com



Revision History

Rev A	Initial Release
Rev B	Better DREQ description. Improved description of FIFO. Improved description of FIFO _{CON_STAT} . Corrected PWM Period formula. Added DM9820 information.
Rev C	Added DM8820. Added AS9100.
Rev D	Changed to new manual format. Added ability to retrigger programmable clocks. Added register to read programmable clock current value. Added FIFO empty flag as a peripheral output. Added IDAN section.

Advanced Analog I/O, Advanced Digital I/O, aAIO, aDIO, a2DIO, Autonomous SmartCal, "Catch the Express", cpuModule, dspFramework, dspModule, expressMafe, ExpressPlatform, HiDANplus, "ML Value for COTS prices", multiPort, PlatformBus, and PC/104EZ are trademarks, and "Accessing the Analog World", dataModule, IDAN, HiDAN, RTD, and the RTD logo are registered trademarks of RTD Embedded Technologies, Inc (formerly Real Time Devices, Inc.). PS/2 is a trademark of International Business Machines Inc. PCI, PCI Express, and PCIe are trademarks of PCI-SIG. PC/104, PC/104-Plus, PCI-104, PCIe/104, PCI/104-Express and 104 are trademarks of the PC/104 Embedded Consortium. All other trademarks appearing in this document are the property of their respective owners.

Failure to follow the instructions found in this manual may result in damage to the product described in this manual, or other components of the system. The procedure set forth in this manual shall only be performed by persons qualified to service electronic equipment. Contents and specifications within this manual are given without warranty, and are subject to change without notice. RTD Embedded Technologies, Inc. shall not be liable for errors or omissions in this manual, or for any loss, damage, or injury in connection with the use of this manual.

Copyright © 2013 by RTD Embedded Technologies, Inc. All rights reserved.

Table of Contents

1	Introduction	8
1.1	Product Overview.....	8
1.2	Board Features.....	8
1.3	Ordering Information.....	9
1.4	Contact Information.....	9
1.4.1	Sales Support.....	9
1.4.2	Technical Support.....	9
2	Specifications	10
2.1	Operating Conditions.....	10
2.2	Electrical Characteristics.....	10
	Notes.....	10
3	Board Connection	11
3.1	Board Handling Precautions.....	11
3.2	Physical Characteristics.....	11
3.3	Connectors and Jumpers.....	11
3.3.1	DM7820HR and DM8820HR.....	11
3.3.1	DM35820HR and DM9820HR.....	12
3.3.2	External I/O Connectors.....	12
	Connector CN10 – Digital Input / Output.....	12
	Connector CN11 – Digital Input / Output.....	13
3.3.3	Bus Connectors.....	14
	PC/104-Express Bus Connectors (DM9820HR Only).....	14
	PC/104-Plus PCI Connector.....	14
	PC/104 ISA Connectors (DM7820HR Only).....	15
3.4	Steps for Installing.....	16
4	IDAN Connections	17
4.1	Module Handling Precautions.....	17
4.2	62D - Physical Characteristics.....	17
4.3	62D - Connectors.....	18
4.4	68S - Physical Characteristics.....	19
4.5	68S – Connectors.....	20
4.6	Bus Connectors.....	21
	PC/104-Express Bus Connectors (DM9820HR Only).....	21
	PC/104-Plus PCI Connector.....	21
	PC/104 ISA Connectors (DM7820HR Only).....	21
4.7	Steps for Installing.....	22
5	Functional Description	23
5.1	Block Diagram.....	23
5.2	Internal Architecture.....	24
5.3	FIFOs.....	24
5.4	Board Interrupts.....	25
5.5	Advanced Triggering Examples.....	25
6	Board Operation and Programming	27
6.1	PCI Interface.....	27

6.2	Device Memory	27
6.2.1	Memory Map Overview	27
6.3	Detailed Register Description	36
6.3.1	System Block	36
	FPGA_VERSION	36
	SVN_VERSION	36
	BOARD_RESET	37
	BRD_STAT	37
	INT_ENABLE	37
	INT_STATUS	38
6.3.2	Standard I/O	39
	PORTx_OUTPUT	40
	PORTx_INPUT	40
	PORTx_TRISTATE	40
	PORTx_MODE	40
	PORTx_PERIPH_SEL_L	41
	PORTx_PERIPH_SEL_H	41
	STROBE_STATUS	42
6.3.3	82C54 Timer Counter Control	43
	TC_ID	43
	TC_INT	43
	TC_xy_CONTROL	43
6.3.4	FIFO Channel n	44
	FIFO _n _ID	44
	FIFO _n _INT	45
	FIFO _n _IN_CLK	45
	FIFO _n _OUT_CLK	46
	FIFO _n _IN_DATA_DREQ	46
	FIFO _n _CON_STAT	47
	FIFO _n _RW_PORT	47
6.3.5	Programmable Clock n	48
	PROGCLK _n _ID	48
	PROGCLK _n _MODE	48
	PRGCLK _n _CLK	48
	PRGCLK _n _START_STOP	49
	PROGCLK _n _PERIOD	50
	PROGCLK _n _COUNT	50
6.3.6	Advanced Interrupt n	51
	ADVINT _n _ID	51
	ADVINT _n _INT_MODE	51
	ADVINT _n _CLK	51
	ADVINT _n _PORTx_MASK	52
	ADVINT _n _PORTx_CMP	52
	ADVINT _n _PORTx_CAPT	52
6.3.7	Dual Incremental Encoder n	53
	INCENC _n _ID	53
	INCENC _n _INT	54
	INCENC _n _CLK	55
	INCENC _n _MODE	55
	INCENC _n _VALUE _y	56
6.3.8	Quad Pulse Width Modulator n	56
	PWM _n _ID	57
	PWM _n _MODE	57
	PWM _n _CLK	57
	PWM _n _PERIOD	58
	PWM _n _WIDTH _x	58
6.3.9	82C54 Timer Counter n	58
	DESCRIPTION OF OPERATION	58
	Control Word and Count Value Program	58
	Mode definition	60
	Reading Counter Values	63
6.4	PLX Registers	67
6.4.1	Memory Map Overview	67
6.4.2	DMA Register Description	67
	DMAMODEN	67

	DMAPADRn.....	69
	DMALAPADRn	69
	DMASIZn	70
	DMAPRn.....	70
	DMACSRn	70
	DMAARB	71
	DMATHR	71
	DMADAn.....	73
	INTCSR	73
7	Troubleshooting	76
8	Additional Information	77
8.1	PC/104 Specifications.....	77
8.2	PCI and PCI Express Specification	77
8.3	PLX PCI9056	77
8.4	82C54 Timer/Counter Programming.....	77
8.5	Interrupt Programming.....	77
9	Limited Warranty	78

Table of Figures

Figure 1: DM7820HR and DM8820HR Connectors and Jumpers	11
Figure 2: DM7820HR and DM8820HR Connectors and Jumpers	12
Figure 3: Example 104™ Stack	16
Figure 4: IDAN Dimensions	17
Figure 5: IDAN Dimensions	19
Figure 6: Example IDAN System	22
Figure 7: DMx820HR Block Diagram	23
Figure 8: Digital I/O Block Diagram	24
Figure 9: Interrupt Diagram	25
Figure 10: Digital I/O Block Diagram	40
Figure 11: Incremental Encoder Signals	53
Figure 12: PWM Output	57
Figure 13: Counter latching executed for counter #1 (Read/Load 2-byte setting)	64

Table of Tables

Table 1: Ordering Options	9
Table 2: Operating Conditions	10
Table 3: Electrical Characteristics	10
Table 4: CN10 Pin Assignments	12
Table 5: CN11 Pin Assignments	13
Table 6: CN10 Pin Assignments	18
Table 7: CN10 Pin Assignments	20
Table 8: PCI Configuration Registers	27
Table 9: DMx820HR Memory Map	28
Table 10: Peripheral Outputs	41
Table 11: Incremental Encoder Inputs	53
Table 12: Select Counter SC[1:0]: Selection of set counter	59
Table 13: Read/Load RL[1:0]: Count Value Reading/Loading format setting	59
Table 14: Mode M[2:0]: Operation waveform mode setting	59
Table 15: BCD: Operation count mode setting	59
Table 16: PLX DMx820HR Memory Map	67
Table 17: DMA Threshold Nybble Values	72

1 Introduction

1.1 Product Overview

The DM7820HR/DM8820HR/DM9820HR is designed to provide high speed digital I/O for PC/104-Plus, PCI-104, PCI/104-Express, and PCIe/104 Systems. It interfaces with the PCI or PCI Express bus and uses large FIFOs and DMA transfers to allow for efficient data management. Several peripherals, including Pulse Width Modulators, Incremental Encoders, and Programmable Clocks are also provided.

1.2 Board Features

- Digital I/O
 - 48 Diode protected I/O lines
 - 24 mA source and sink current
 - Compatible with DMR and DOP expansion boards
- Deep FIFOs with DMA
 - Two 2M-Word FIFOs
 - Each FIFO is attached to a separate DMA channel
 - 25 MHz bursted throughput
 - 12.5 MHz continuous throughput
 - FIFO can be looped
- Pulse Width Modulators
 - Eight PWM outputs
 - Single-ended or Differential Outputs
 - 16-bit resolution
 - Separate period and width clocks provide full resolution at low duty cycles
 - Optional Interrupt generations
- Incremental Encoders
 - Four Incremental Encoder channels
 - Single-ended or Pseudo-differential Inputs
 - Variable frequency input filtering
 - Max input speed of 40ns per transition
 - 16-bit resolution
 - Two channels can be combined for 32-bit resolution
 - Connect to FIFO for position sampling
- Advanced Interrupts
 - Two Advanced Interrupt Modules
 - Interrupt on Match, Change, or Strobe
 - All 48 bits are captured when the interrupt is generated
 - Any combination of the 48 bits can be monitored
- Programmable Clocks
 - Four programmable clocks
 - Maximum frequency of 25 MHz
 - Can be started and stopped by an interrupt or another clock
 - Continuous or One-Shot Operation
 - Can be cascaded
- 82C54 Timer/Counters
 - Six Timer/Counter Channels
 - Fully programmable
 - Input clock and gate driven from internal or external source
 - 10 MHz maximum input

1.3 Ordering Information

The DMx820HR is available with the following options:

Table 1: Ordering Options

Part Number	Description
DM35820HR	PCIe/104 High-Speed Digital I/O DAQ Module
DM9820HR	PCI/104-Express High-Speed Digital I/O DAQ Module
DM8820HR	PCI-104 High-Speed Digital I/O DAQ Module
DM7820HR	PC/104-Plus High-Speed Digital I/O DAQ Module
IDAN-DM35820HR-62D	PCIe/104 High-Speed Digital I/O DAQ Module in IDAN enclosure
IDAN-DM9820HR-62D	PCI/104-Express High-Speed Digital I/O DAQ Module in IDAN enclosure
IDAN-DM8820HR-68S	PCI-104 High-Speed Digital I/O DAQ Module in IDAN enclosure
IDAN-DM7820HR-68S	PC/104-Plus High-Speed Digital I/O DAQ Module in IDAN enclosure

The Intelligent Data Acquisition Node (IDAN™) building block can be used in just about any combination with other IDAN building blocks to create a simple but rugged 104™ stack. This module can also be incorporated in a custom-built RTD HiDAN™ or HiDANplus High Reliability Intelligent Data Acquisition Node. Contact RTD sales for more information on our high reliability systems.

1.4 Contact Information

1.4.1 SALES SUPPORT

For sales inquiries, you can contact RTD Embedded Technologies sales via the following methods:

Phone: 1-814-234-8087 Monday through Friday, 8:00am to 5:00pm (EST).
 E-Mail: sales@rtd.com

1.4.2 TECHNICAL SUPPORT

If you are having problems with your system, please try the steps in the Troubleshooting section of this manual on page 76.

For help with this product, or any other product made by RTD, you can contact RTD Embedded Technologies technical support via the following methods:

Phone: 1-814-234-8087 Monday through Friday, 8:00am to 5:00pm (EST).
 E-Mail: techsupport@rtd.com

2 Specifications

2.1 Operating Conditions

Table 2: Operating Conditions

Symbol	Parameter	Test Condition	Min	Max	Unit
V_{cc5}	5V Supply Voltage		4.75	5.25	V
T_a	Operating Temperature		-40	+85	C
T_s	Storage Temperature		-55	+125	C
RH	Relative Humidity	Non-Condensing	0	90%	%
MTBF	Mean Time Before Failure	Telcordia Issue 2 30°C, Ground benign, controlled	3,292,579		Hours

2.2 Electrical Characteristics

Table 3: Electrical Characteristics

Symbol	Parameter	Test Condition	Min	Max	Unit
P	Power Consumption	$V_{cc5} = 5.0V$		1.5	W
I_{cc5}	5V Input Supply Current	Active		300	mA
PCI Bus					
V_{IH}	Input High Voltage		1.65	5.5	V
V_{IL}	Input Low Voltage		0	0.8	V
I_{IL}	PCI Input Leakage	$0 < V_I < V_{IO}$	-10	10	μA
I_{OZ}	PCI Hi-Z Leakage	$0 < V_I < V_{IO}$		10	μA
V_{OH}	Output High Voltage		2.97		V
V_{OL}	Output Low Voltage			0.33	V
PCIe Bus					
	Differential Output Voltage		0.8	1.2	V
	DC Differential TX Impedance		95.2	116.9	Ω
	Differential Input Voltage		0.175	3.3	V
	DC Differential RX Impedance		92.7	115.8	Ω
	Electrical Idle Detect Threshold		61	173	mV
Digital I/O					
V_{IH}	Input High Voltage		2.0	5.5	V
V_{IL}	Input Low Voltage		-0.5	0.8	V
V_{OH}	Output High Voltage	$I_{OH} = -24mA$	2.4		V
V_{OL}	Output Low Voltage	$I_{OL} = 24mA$		0.4	V

Notes

1. DIO Vin DC overshoot must be limited to either 5.5V or 10mA and DC undershoot must be limited to either -0.5V or 10mA.
2. DIO pins may be driven to -2.0V or +7.0V provided these voltages last no longer than 11ns with a forcing current no greater than 100mA.
3. Inputs are terminated with 33 Ω resistors and protection diodes.
4. DIO inputs should not be tied to voltages when the board is not powered.

3 Board Connection

3.1 Board Handling Precautions

To prevent damage due to Electrostatic Discharge (ESD), keep your board in its antistatic bag until you are ready to install it into your system. When removing it from the bag, hold the board at the edges, and do not touch the components or connectors. Handle the board in an antistatic environment, and use a grounded workbench for testing and handling of your hardware.

3.2 Physical Characteristics

- Weight: Approximately 100 g (0.22 lbs.)
- Dimensions: 90.17 mm L x 95.89 mm W (3.550 in L x 3.775 in W)

3.3 Connectors and Jumpers

3.3.1 DM7820HR AND DM8820HR

The following diagram shows the location of all connectors and jumpers on the DM7820HR and DM8820HR. The DM7820HR and DM8820HR are identical, except that the DM8820HR does not have the PC/104 (ISA) connector populated. For a description of each jumper and connector, refer to the following sections.

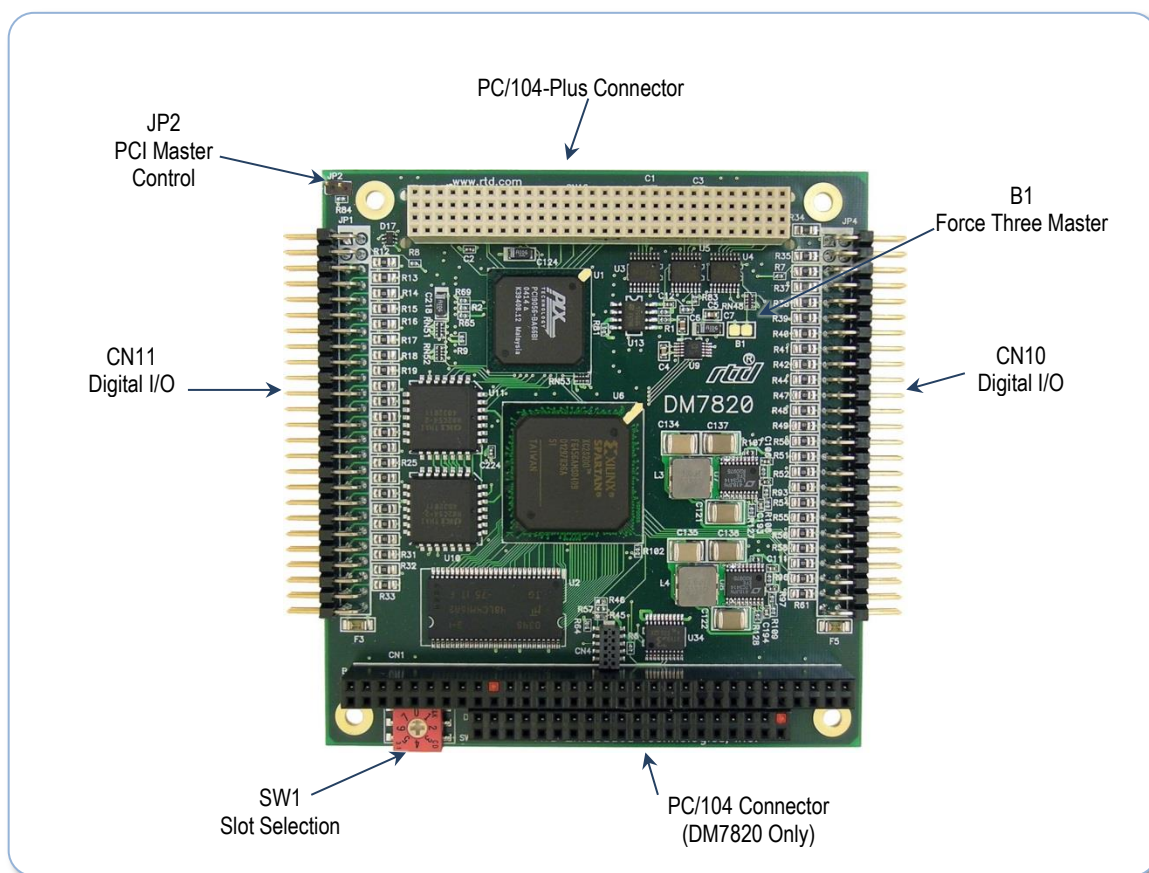

Figure 1: DM7820HR and DM8820HR Connectors and Jumpers

3.3.1 DM35820HR AND DM9820HR

The following diagram shows the location of all connectors and jumpers on the DM9820HR. For a description of each jumper and connector, refer to the following sections.

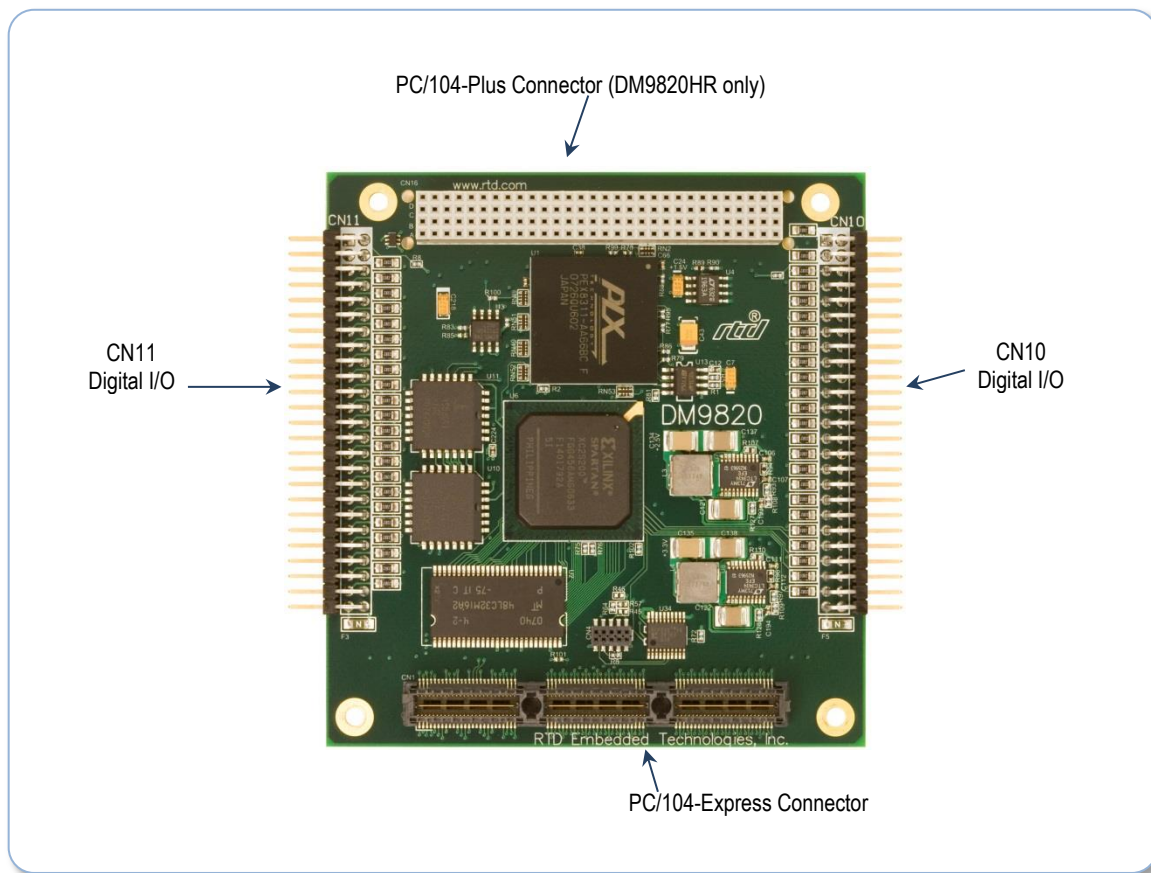

Figure 2: DM7820HR and DM8820HR Connectors and Jumpers

3.3.2 EXTERNAL I/O CONNECTORS



NOTE: Pin 1 can be identified by a square solder pad. Pins 2 – 50 have round solder pads.

Connector CN10 – Digital Input / Output

Connector CN10 provides 24 digital input/output lines, along with a +5V pin and ground pins. The pin assignments for CN10 are shown in Table 1.

Table 4: CN10 Pin Assignments

Signal	Pin	Pin	Signal
P2[7]	1	2	Strobe2
P2[6]	3	4	GND
P2[5]	5	6	GND
P2[4]	7	8	GND
P2[3]	9	10	GND
P2[2]	11	12	GND
P2[1]	13	14	GND
P2[0]	15	16	GND

Table 4: CN10 Pin Assignments

Signal	Pin	Pin	Signal
P0[15]	17	18	GND
P0[14]	19	20	GND
P0[13]	21	22	GND
P0[12]	23	24	GND
P0[11]	25	26	GND
P0[10]	27	28	GND
P0[9]	29	30	GND
P0[8]	31	32	GND
P0[7]	33	34	GND
P0[6]	35	36	GND
P0[5]	37	38	GND
P0[4]	39	40	GND
P0[3]	41	42	GND
P0[2]	43	44	GND
P0[1]	45	46	GND
P0[0]	47	48	GND
+5V, 2A max	49	50	GND

See Table 10 on page 41 Table 10 and Table 11 on page 53 for peripheral pin assignments.

Connector CN11 – Digital Input / Output

Connector CN11 provides 24 digital input/output lines, along with a +5V pin and ground pins. The pin assignments for CN11 are shown in Table 2.

Table 5: CN11 Pin Assignments

Signal	Pin	Pin	Signal
P2[15]	1	2	Strobe1
P2[14]	3	4	GND
P2[13]	5	6	GND
P2[12]	7	8	GND
P2[11]	9	10	GND
P2[10]	11	12	GND
P2[9]	13	14	GND
P2[8]	15	16	GND
P1[15]	17	18	GND
P1[14]	19	20	GND
P1[13]	21	22	GND
P1[12]	23	24	GND
P1[11]	25	26	GND
P1[10]	27	28	GND
P1[9]	29	30	GND
P1[8]	31	32	GND
P1[7]	33	34	GND
P1[6]	35	36	GND
P1[5]	37	38	GND
P1[4]	39	40	GND
P1[3]	41	42	GND
P1[2]	43	44	GND
P1[1]	45	46	GND
P1[0]	47	48	GND
+5V, 2A max	49	50	GND

See Table 10 on page 41 Table 10 and Table 11 on page 53 for peripheral pin assignments.

3.3.3 BUS CONNECTORS

PC/104-Express Bus Connectors (DM9820HR Only)

The PCIe connector is the connection to the system CPU. The position and pin assignments are compliant with the *PCI/104-Express Specification*. (See PC/104 Specifications on page 77)

This board is a “Universal” board, and can connect to either a Type 1 or Type 2 PCIe/104 connector.

PC/104-Plus PCI Connector

The PC/104-Plus connector carries the signals of the PC/104-Plus PCI bus. Refer to PC/104-Plus™ Specification for the pinout of this connector. The DM9820HR connects to the power and ground pins only, and does not use any of the signals. The DM7820HR uses this connector for communication with the CPU.

PCI Configuration Options (DM7820HR Only)

To install the DM7820HR into the stack, the PCI Slot Number must be configured correctly. This is done by the PCI Slot Selector located at SW1.

There are four possible PCI Slot Numbers (0 – 3). Each PCI device (PC/104-Plus or PCI-104) must use a different slot number. The slot number is related to the position of the board in the stack. Slot 0 represents the PCI device closest to the CPU. Slot 3 represents the PCI devices farthest away from the CPU.



NOTE: In a PC/104-Plus or PCI-104 system, all PCI devices should be located on one side of the CPU board (above or below the add-on cards). The CPU should not be located between two PCI devices.

Switch SW1 – PCI Slot Selector

When the PC/104-Plus Specification was first introduced, it only allowed for three PCI add-on cards to be bus masters. Version 2.0 of the PC/104-Plus specification was released in November 2003. This version of the specification (which the DM7820HR is designed for) adds support for all 4 PCI slots to be bus masters.

There are two methods for compatibility with CPUs designed for the older PC/104-Plus Specification. One method is to use slot positions 4-7 instead of the usual 0-3. The second is to short solder jumper B1.

The PCI Slot Number can be configured as follows:

Switch Position	PCI Slot Number	Compatibility	Master
0	Slot 0 (closest to CPU)	4	yes
1	Slot 1	4	yes
2	Slot 2	4	yes
3	Slot 3	4	yes
4	Slot 0 (closest to CPU)	3	yes
5	Slot 1	3	yes
6	Slot 2	3	If JP2
7	Slot 3	3	If JP2

Jumper JP2 – Bus Master Control

Install JP2 to enable bus mastering when in Slot 2 or Slot 3 in three bus master mode.

Solder Blob B1 – Force Three Master

The DM7820HR offers a configuration solder blob at location B1. If this solder blob is open (the default), the board supports bus mastering in all 4 PCI slots when SW1 is in position 0-3. If it is closed, the board will work in a 3 bus master configuration. If B1 is closed, SW1 positions 0-3 will be identical to positions 4-7.



NOTE: The DM7820HR comes with solder blob B1 open by default. This should be compatible with most PC/104-Plus CPUs. There is no need to change this blob unless you are having compatibility problems with your specific CPU.

PC/104 ISA Connectors (DM7820HR Only)

The PC/104 connectors carry the signals of the PC/104-Plus ISA bus. Refer to PC/104-Plus Specification Revision 1.0 for the pinout of this connector. This is a pass-through connector. The DM7820HR connects to the power and ground pins only, and does not use any of the signals.

3.4 Steps for Installing

5. Always work at an ESD protected workstation, and wear a grounded wrist-strap.
6. Turn off power to the PC/104 system or stack.
7. Select and install stand-offs to properly position the module on the stack.
8. Remove the module from its anti-static bag.
9. Check that pins of the bus connector are properly positioned.
10. Check the stacking order; make sure all of the busses used by the peripheral cards are connected to the cpuModule.
11. Hold the module by its edges and orient it so the bus connector pins line up with the matching connector on the stack.
12. Gently and evenly press the module onto the PC/104 stack.
13. If any boards are to be stacked above this module, install them.
14. Attach any necessary cables to the PC/104 stack.
15. Re-connect the power cord and apply power to the stack.
16. Boot the system and verify that all of the hardware is working properly.

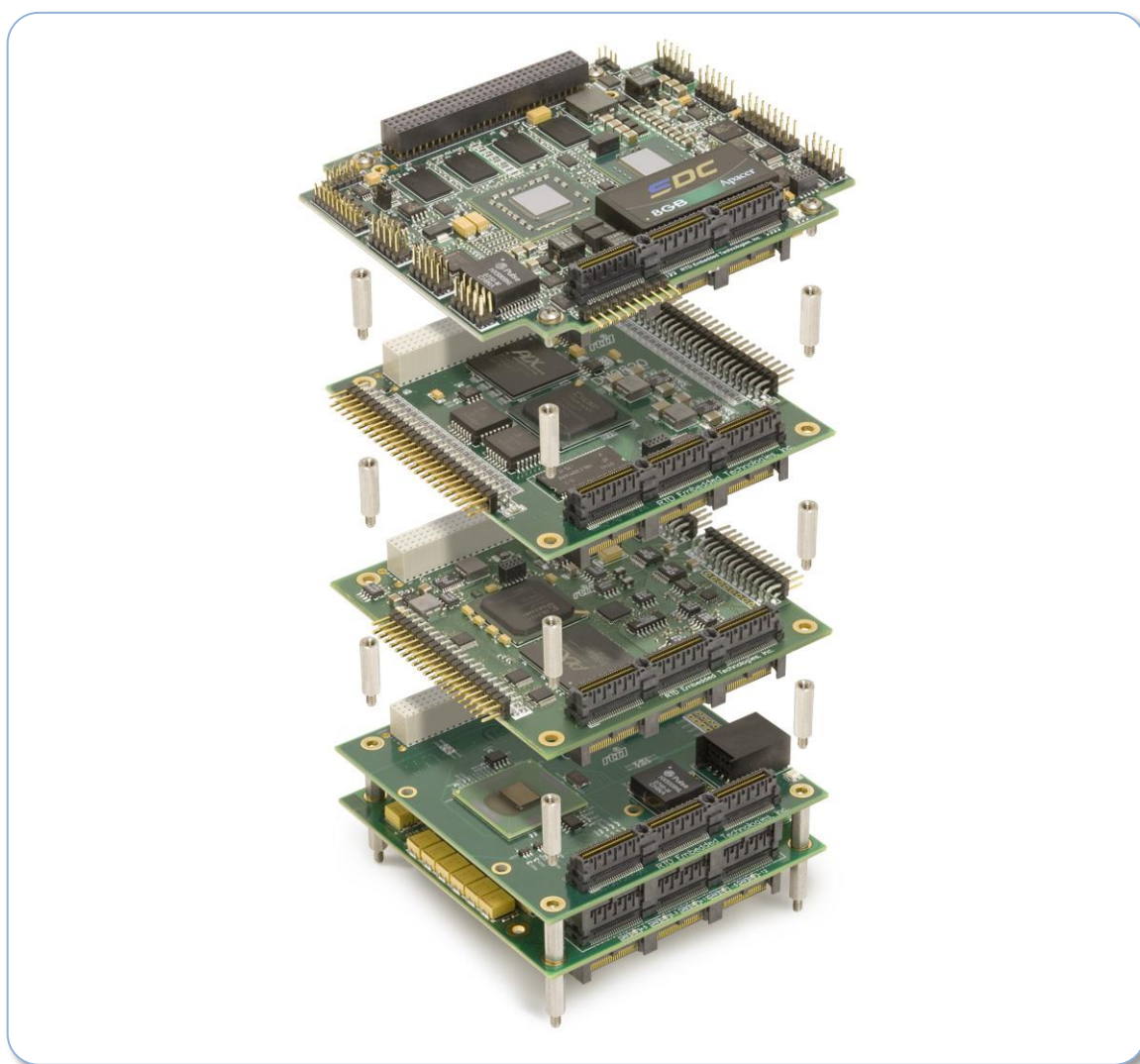

Figure 3: Example 104™ Stack

4 IDAN Connections

4.1 Module Handling Precautions

To prevent damage due to Electrostatic Discharge (ESD), keep your module in its antistatic bag until you are ready to install it into your system. When removing it from the bag, hold the module by the aluminum enclosure, and do not touch the components or connectors. Handle the module in an antistatic environment, and use a grounded workbench for testing and handling of your hardware.

4.2 62D - Physical Characteristics

- Weight: Approximately 0.21 Kg (0.46 lbs.)
- Dimensions: 151.972 mm L x 129.978 mm W x 33.934 mm H (5.983 in L x 5.117 in W x 1.339 in H)

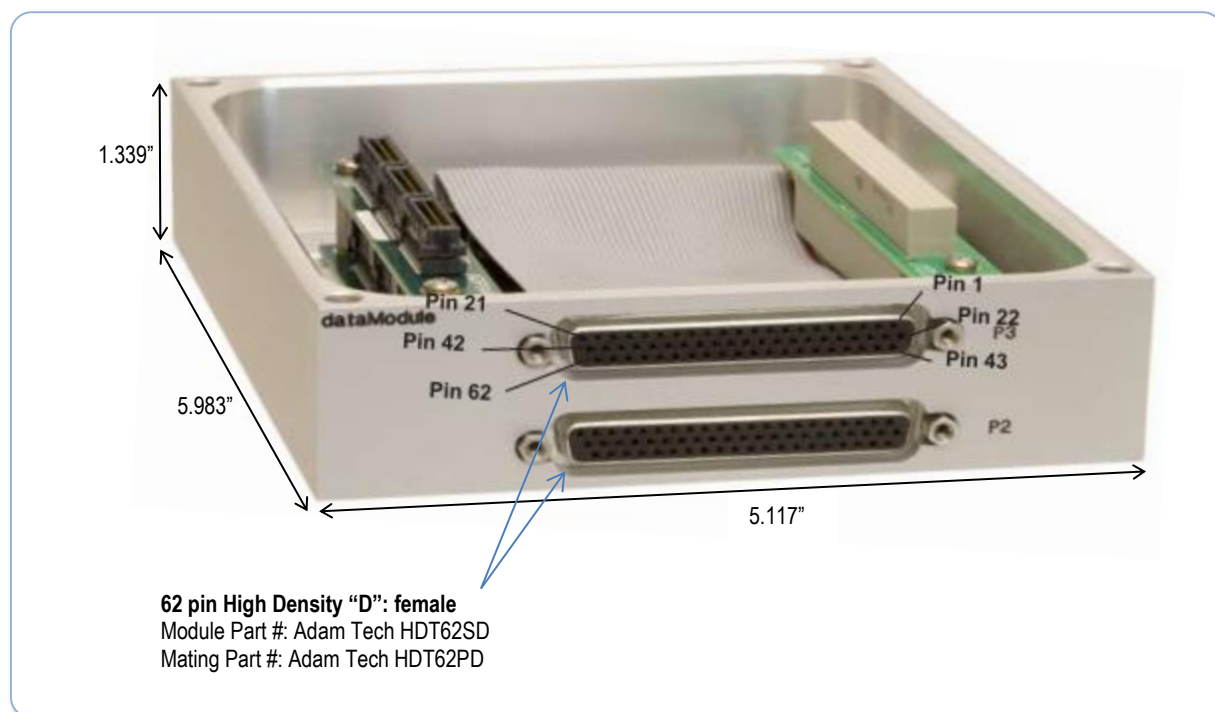

Figure 4: IDAN Dimensions

4.3 62D - Connectors

Table 6: CN10 Pin Assignments

IDAN P2 Pin			Signal	CN10 Pin
Row 1	Row 2	Row 3		
1			P2.7	1
	22		STROBE 2	2
		43	P2.6	3
2			GND	4
	23		P2.5	5
		44	GND	6
3			P2.4	7
	24		GND	8
		45	P2.3	9
4			GND	10
	25		P2.2	11
		46	GND	12
5			P2.1	13
	26		GND	14
		47	P2.0	15
6			GND	16
	27		P0.15	17
		48	GND	18
7			P0.14	19
	28		GND	20
		49	P0.13	21
8			GND	22
	29		P0.12	23
		50	GND	24
9			P0.11	25
	30		GND	26
		51	P0.10	27
10			GND	28
	31		P0.9	29
		52	GND	30
11			P0.8	31
	32		GND	32
		53	P0.7	33
12			GND	34
	33		P0.6	35
		54	GND	36
13			P0.5	37
	34		GND	38
		55	P0.4	39
14			GND	40
	35		P0.3	41
		56	GND	42
15			P0.2	43
	36		GND	44
		57	P0.1	45
16			GND	46
	37		P0.0	47
		58	GND	48
17			5 VOLTS	49
	38		GND	50

* Pins 51 to 62 of the IDAN connector are not connected.

IDAN P3 Pin			Signal	CN11 Pin
Row 1	Row 2	Row 3		
1			P2.15	1
	22		STROBE 2	2
		43	P2.14	3
2			GND	4
	23		P2.13	5
		44	GND	6
3			P2.12	7
	24		GND	8
		45	P2.11	9
4			GND	10
	25		P2.10	11
		46	GND	12
5			P2.9	13
	26		GND	14
		47	P2.8	15
6			GND	16
	27		P1.15	17
		48	GND	18
7			P1.14	19
	28		GND	20
		49	P1.13	21
8			GND	22
	29		P1.12	23
		50	GND	24
9			P1.11	25
	30		GND	26
		51	P1.10	27
10			GND	28
	31		P1.9	29
		52	GND	30
11			P1.8	31
	32		GND	32
		53	P1.7	33
12			GND	34
	33		P1.6	35
		54	GND	36
13			P1.5	37
	34		GND	38
		55	P1.4	39
14			GND	40
	35		P1.3	41
		56	GND	42
15			P1.2	43
	36		GND	44
		57	P1.1	45
16			GND	46
	37		P1.0	47
		58	GND	48
17			5 VOLTS	49
	38		GND	50

4.4 68S - Physical Characteristics

- Weight: Approximately 0.21 Kg (0.46 lbs.)
- Dimensions: 151.972 mm L x 129.978 mm W x 16.993 mm H (5.983 in L x 5.117 in W x 0.669 in H)

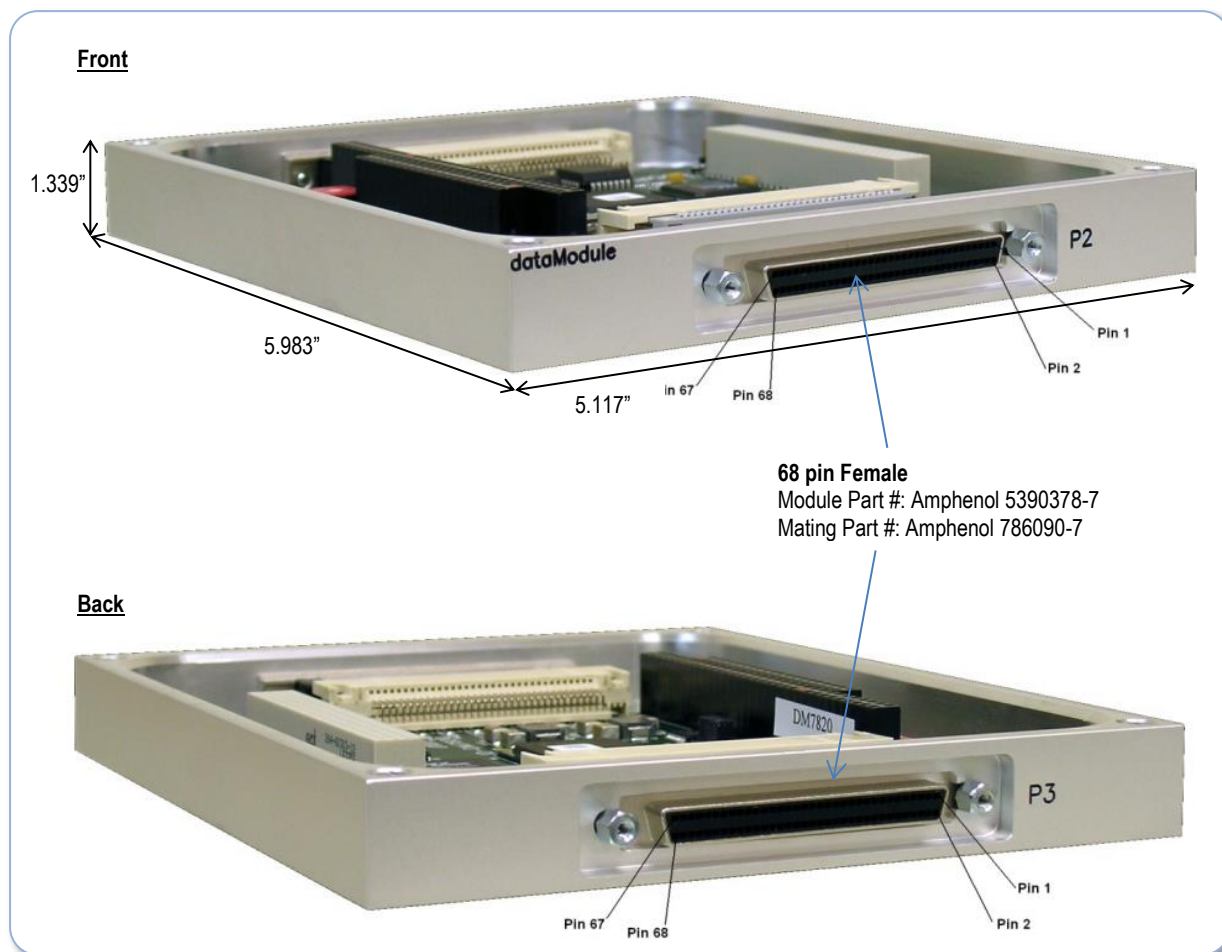

Figure 5: IDAN Dimensions

4.5 68S – Connectors

Table 7: CN10 Pin Assignments

IDAN P2 Pin		Signal	CN10 Pin
Row 1	Row 2		
1		P2.7	1
	2	STROBE 2	2
3		P2.6	3
	4	GND	4
5		P2.5	5
	6	GND	6
7		P2.4	7
	8	GND	8
9		P2.3	9
	10	GND	10
11		P2.2	11
	12	GND	12
13		P2.1	13
	14	GND	14
15		P2.0	15
	16	GND	16
17		P0.15	17
	18	GND	18
19		P0.14	19
	20	GND	20
21		P0.13	21
	22	GND	22
23		P0.12	23
	24	GND	24
25		P0.11	25
	26	GND	26
27		P0.10	27
	28	GND	28
29		P0.9	29
	30	GND	30
31		P0.8	31
	32	GND	32
33		P0.7	33
	34	GND	34
35		P0.6	35
	36	GND	36
37		P0.5	37
	38	GND	38
39		P0.4	39
	40	GND	40
41		P0.3	41
	42	GND	42
43		P0.2	43
	44	GND	44
45		P0.1	45
	46	GND	46
47		P0.0	47
	48	GND	48
49		5 VOLTS	49
	50	GND	50

IDAN P3 Pin		Signal	CN11 Pin
Row 1	Row 2		
1		P2.15	1
	2	STROBE 2	2
3		P2.14	3
	4	GND	4
5		P2.13	5
	6	GND	6
7		P2.12	7
	8	GND	8
9		P2.11	9
	10	GND	10
11		P2.10	11
	12	GND	12
13		P2.9	13
	14	GND	14
15		P2.8	15
	16	GND	16
17		P1.15	17
	18	GND	18
19		P1.14	19
	20	GND	20
21		P1.13	21
	22	GND	22
23		P1.12	23
	24	GND	24
25		P1.11	25
	26	GND	26
27		P1.10	27
	28	GND	28
29		P1.9	29
	30	GND	30
31		P1.8	31
	32	GND	32
33		P1.7	33
	34	GND	34
35		P1.6	35
	36	GND	36
37		P1.5	37
	38	GND	38
39		P1.4	39
	40	GND	40
41		P1.3	41
	42	GND	42
43		P1.2	43
	44	GND	44
45		P1.1	45
	46	GND	46
47		P1.0	47
	48	GND	48
49		5 VOLTS	49
	50	GND	50

* Pins 51 to 68 of the IDAN connector are not connected.

4.6 Bus Connectors

PC/104-Express Bus Connectors (DM9820HR Only)

The PCIe connector is the connection to the system CPU. The position and pin assignments are compliant with the *PCI/104-Express Specification*. (See PC/104 Specifications on page 77)

This board is a "Universal" board, and can connect to either a Type 1 or Type 2 PCIe/104 connector.

PC/104-Plus PCI Connector

The PC/104-Plus connector carries the signals of the PC/104-Plus PCI bus. Refer to PC/104-Plus™ Specification for the pinout of this connector. The DM9820HR connects to the power and ground pins only, and does not use any of the signals. The DM7820HR uses this connector for communication with the CPU.

PCI Configuration Options (DM7820HR Only)

See PCI Configuration Options (DM7820HR Only) on page 14.

PC/104 ISA Connectors (DM7820HR Only)

The PC/104 connectors carry the signals of the PC/104-Plus ISA bus. Refer to PC/104-Plus Specification Revision 1.0 for the pinout of this connector. This is a pass-through connector. The DM7820HR connects to the power and ground pins only, and does not use any of the signals.

4.7 Steps for Installing

1. Always work at an ESD protected workstation, and wear a grounded wrist-strap.
2. Turn off power to the IDAN system.
3. Remove the module from its anti-static bag.
4. Check that pins of the bus connector are properly positioned.
5. Check the stacking order; make sure all of the busses used by the peripheral cards are connected to the cpuModule.
6. Hold the module by its edges and orient it so the bus connector pins line up with the matching connector on the stack.
7. Gently and evenly press the module onto the IDAN system.
8. If any boards are to be stacked above this module, install them.
9. Finish assembling the IDAN stack by installing screws of an appropriate length.
10. Attach any necessary cables to the IDAN system.
11. Re-connect the power cord and apply power to the stack.
12. Boot the system and verify that all of the hardware is working properly.

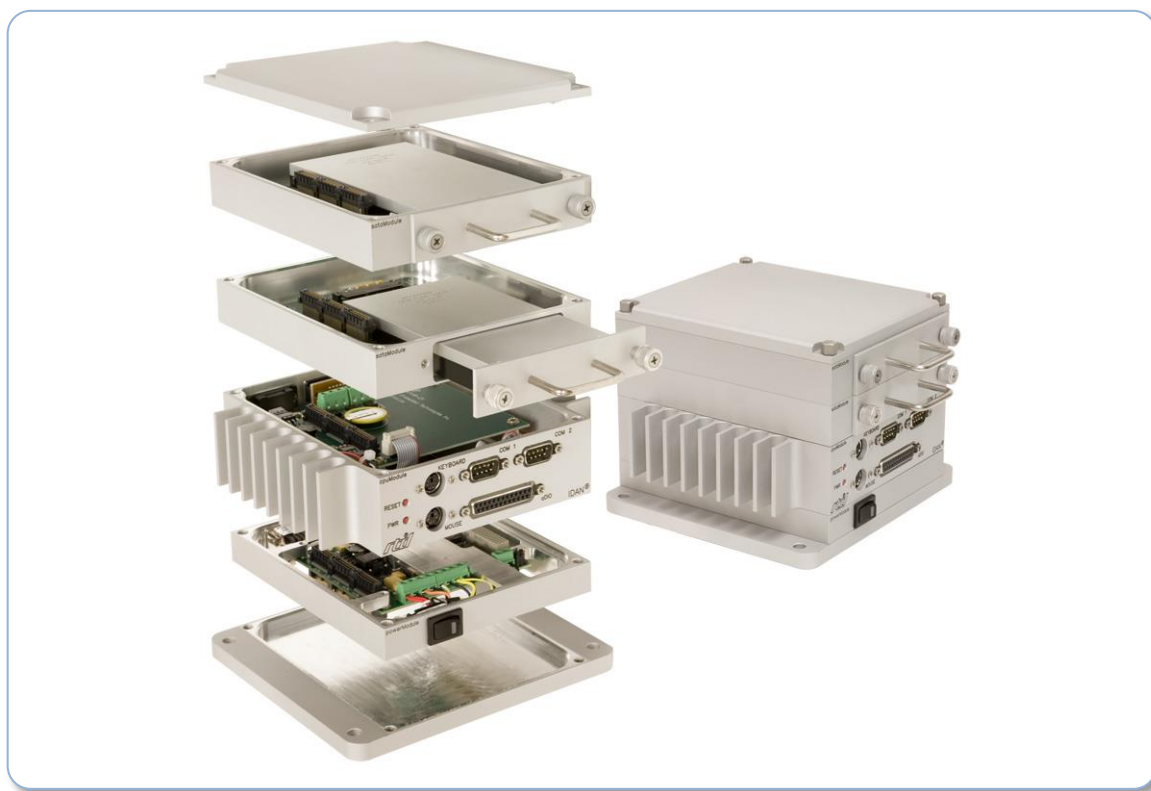

Figure 6: Example IDAN System

5 Functional Description

5.1 Block Diagram

Below is a block diagram of the DMx820HR. Primary board components are in bold, while external I/O connections and jumpers are italicized.

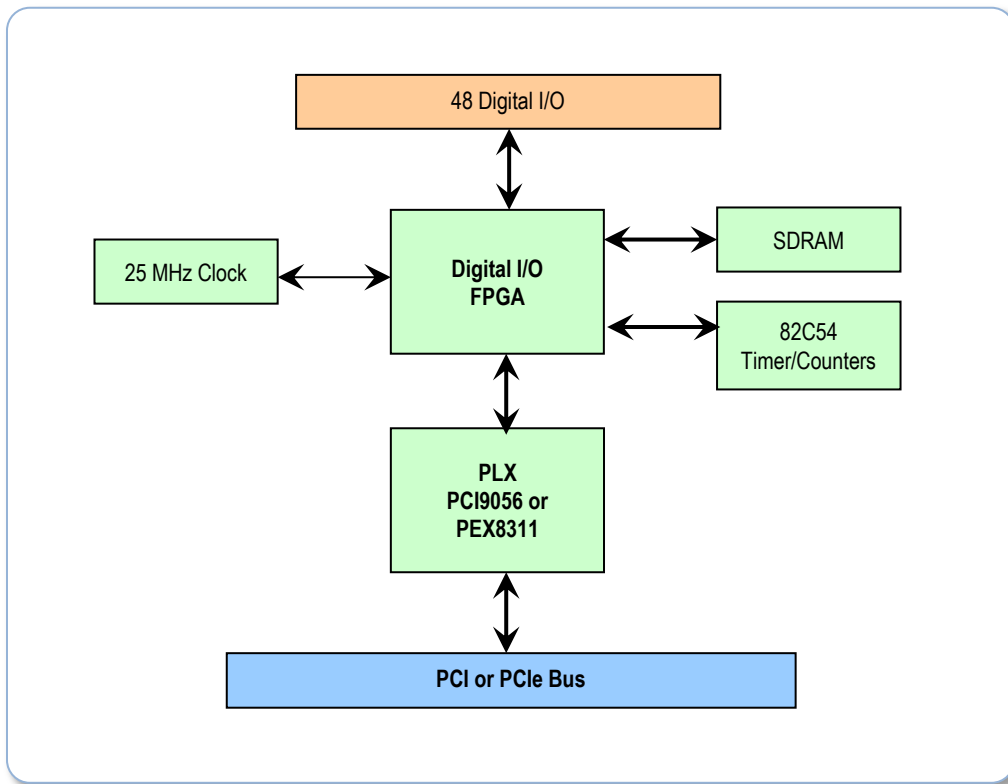

Figure 7: DMx820HR Block Diagram

5.2 Internal Architecture

A diagram of the standard I/O is shown in Figure 10. Each digital I/O pin can be an input, output, or peripheral output. The peripheral outputs are the Pulse Width Modulators, FIFO, Timer/Counters, etc.

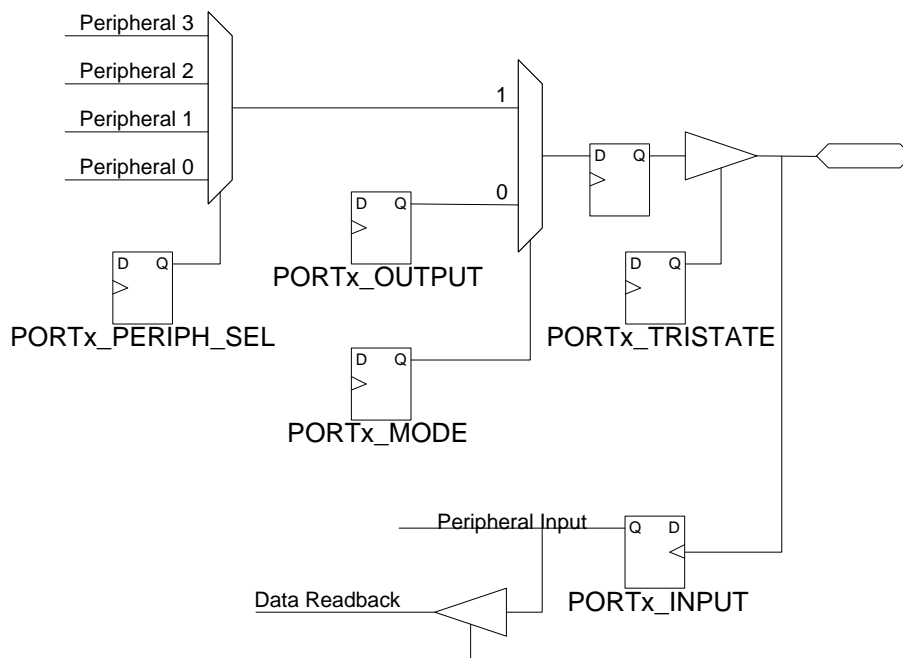

Figure 8: Digital I/O Block Diagram

5.3 FIFOs

The DMx820HR provides two FIFOs to buffer data going into and out of the board. Each FIFO is 16-bit wide and 2,097,661 Words deep. The input strobe, output strobe, and data input for each FIFO can be individually selected. The output data is made available to the peripheral outputs, and also the PCI interface.

Each FIFO is attached to a DMA Channel in the PLX chip. FIFO0 is attached to DMA0, and FIFO1 is attached to DMA1.

FIFO0 can have its input data attached to its output data. In this case, the same data is repeated forever. This is useful for some types of pattern generation.

Internally, the FIFO system consists of a single 8MB SDRAM device, with 255-word input and output buffers for each channel. When data is available in the input buffer, it is moved into the area of SDRAM device for that channel. When data is in the SDRAM device, and there is room available in the output buffer, data is moved to the output buffer. All of the internal data movement is handled automatically. Greatest data efficiency is achieved when there are at least 128 words of data in the FIFO.

The FIFO also provides “Write Request” and “Read Request” signals. For these signals, the internal buffers are monitored to signal when data can be sent into, and read from the FIFO. The “Write Request” is asserted when there are at least 256 words of space available in the FIFO, and negated when there are less than 128 words available. The “Read Request” is asserted when at least 256 words of data is in the FIFO, and negated when there is less than 128 words of data. Using these signals guarantees a burst of at least 128 words, which provides for efficient communication over the PCI bus, and robustly guards against over-run and under-run conditions. However, it does not allow for the FIFO to be completely filled or emptied.

There is a total of 45 M-words per second of available bandwidth for the entire FIFO system. This bandwidth is allocated between all input and output sources. This is assuming that at least 256 Words stay in the FIFO at all times to maximize bursting (i.e., the Read Request and Write Request are used for DREQ). If only one word is available in the FIFO (i.e. Not Empty is used as for DREQ) the available bandwidth drops to 3.75 M-words per second. When a FIFO is looped, the data must be read and written. The table below shows examples of configurations and their maximum data rate. Note that for uniform sampling (samples are taken at uniform sampling intervals) the data rate must be an integer divisor of the 25 MHz overall clock.

Description	Max Data Rate
One FIFO in use, burst capture only	25 MHz
One FIFO in use, burst output only	25 MHz
One FIFO in use, continuous capture or output	12.5 MHz
Two FIFOs in use, continuous capture/output	12.5 MHz + 6.25 MHz
Two FIFOs in use, continuous capture/output, non-uniform sampling	11 MHz + 11 MHz

5.4 Board Interrupts

There are three levels of interrupt sources for this board: the interrupt sources generated in the PLX chip, the interrupt sources generated by the modules in the Control Block, and the interrupt sources within the modules. Each level must be enabled in the previous level. Figure 9 shows a block diagram of the interrupt sources. Note that there are some other sources in the PLX bridge chip; consult the datasheet for more details.

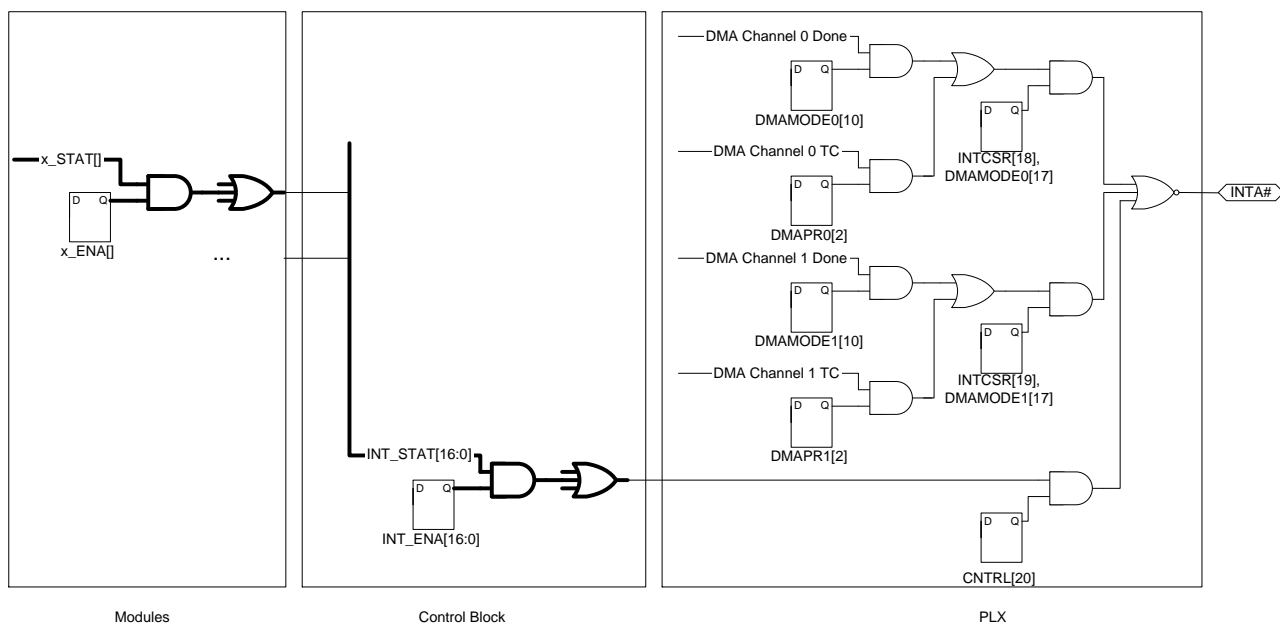

Figure 9: Interrupt Diagram

5.5 Advanced Triggering Examples

The modules on the DMx820HR can be combined to generate a broad range of complex sampling scenarios. The following example shows how to use the Advanced Interrupt and 4 counters to capture N words before and M words after an event. Programmable Clock 0 is the sample clock, and is used to clock data into the FIFO. It is started after all of the other Programmable clocks are initialized. As soon as it starts, Programmable Clock 1 starts counting samples to be captured before the triggering event. This is also known as “pre-fill.” When it expires, it starts Programmable Clock 2, which removes samples from the FIFO at the same rate that they are stored, keeping a constant number of samples in the FIFO. When the triggering event happens, Programmable Clock 2 is stopped, and the FIFO begins to fill. Also, the triggering event starts Programmable Clock 3, which counts the number of samples to be captured after the triggering event. When Programmable Clock 3 expires, it stops Programmable Clock 0, and data collection ends. The triggering event can also generate an interrupt that changes the FIFO output to PCI Read, and start DMA transfers. This allows the data to be moved to system memory before data collection has ended.

- 1) AdvInt0
 - a) Set to event desired
 - b) During the Interrupt Service Routine...
 - i) Change FIFO output clock to PCI Read
 - ii) Start DMA transfers
- 2) Prog Clock 0 - Sample Input Clock
 - a) Period = sample period

- b) Master Clock = any
 - c) Start Event = always
 - d) Stop Event = Prog Clock 3
 - e) Continuous operation
- 3) Prog Clock 1 - Pre-capture clock
- a) Period = N (samples before event)
 - b) Master Clock = Prog Clock 0
 - c) Start Event = always
 - d) One-shot
- 4) Prog Clock 2 - Sample output clock
- a) Period = same as Prog Clock 0
 - b) Master Clock = same as Prog Clock 0
 - c) Start Event = Prog Clock 1
 - d) Stop Event = AdvInt 0
 - e) Continuous
- 5) Prog Clock 3 - Post-Capture clock
- a) Period = M (samples after event)
 - b) Master Clock = Prog Clock 0
 - c) Start Event = AdvInt0
 - d) One-Shot
- 6) FIFO 0
- a) Data In = any
 - b) Data in clock = Prog Clock 0
 - c) Data out clock = Prog Clock 2 (before AdvInt0)
 - d) Data out clock = PCI Read (after Adv Int0)
 - e) DReq0 = Read Ready

6 Board Operation and Programming

6.1 PCI Interface

This board attaches to the PCI bus using a PLX PCI9056. The PCI9056 is operating in "C Mode." Most of the registers in the PLX chip are automatically programmed at power up by the on-board EEPROM or by the system BIOS. The only PLX registers that the user needs to access are the DMA registers found on page 67, and the Configuration Registers found in Table 8 below.

For more information on the PLX PCI9056 bridge chip, contact PLX Technologies, (www.plxtech.com).

Table 8: PCI Configuration Registers

PCI Config. Register Address (Hex)	Register Name			
0x00	PCI Device ID = 0x7820		PCI Vendor ID = 0x1435	
0x04	PCI Status		PCI Command	
0x08	PCI Class Code = 0x118000			PCI Rev. ID = 0x00
0x0C	PCI BIST	PCI Header Type	Bus Latency Timer	Cache Line Size
0x10	PCI Base Address Register 0: Memory Access to PLX9056 Registers			
0x14	PCI Base Address Register 1: I/O Access to PLX9056 Registers			
0x18	PCI Base Address Register 2: Memory Access to Digital I/O Registers			
0x1C	PCI Base Address Register 3: Reserved			
0x20	Reserved			
0x24	Reserved			
0x28	Reserved			
0x2C	PCI Subsystem ID = 0x9056		PCI Subsystem Vendor = 0x10B5	
0x30	Reserved			
0x34	Reserved			Reserved
0x38	Reserved			
0x3C	PCI Max Latency	PCI Min Grant	PCI Interrupt Pin	PCI Interrupt Line

6.2 Device Memory

The DMx820HR is a memory mapped device. The address for the memory mapped registers can be found in Base Address Register 2. Generally, the registers are 16 bits wide. However, they can be read and written as 8, 16, or 32 bits. (There are a few exceptions as noted in the memory map.)

6.2.1 MEMORY MAP OVERVIEW

Table 9 shows the memory map of the DMx820HR digital I/O registers. These are found at the offset from BAR2.

Table 9: DMx820HR Memory Map

Offset (Hex)	Register Name	Register Function
Board Control		
0x0000	FPGA_VERSION	b[15:8] Type ID b[7:0] Version
0x0002	SVN_VERSION	b[15:0] Extended Version
0x0004	BOARD_RESET	Write 0xA5A5 to reset board
0x0006	Reserved	
0x0008	BRD_STAT	b[15:1] Reserved b0 MSTR – 0 = PCI Master Capable, 1 = Not PCI Master Capable (Read Only)
0x0010	INT_ENABLE	b[15:0] Interrupt Enable – Set to '1' to enable a specific interrupt
0x0012	INT_STAT	b [15:0] Interrupt Status – Reading a '1' indicates interrupt condition has occurred. Write a '1' to clear an interrupt bit.
0x0014–0x003E	Reserved	
Standard I/O		
0x0040	PORT0_OUTPUT	b [15:0] Value to port 0 when it is an output.
0x0042	PORT0_INPUT	b [15:0] Read only value from Port 0.
0x0044	PORT0_TRISTATE	b [15:0] '1' for output, '0' for input.
0x0046	PORT0_MODE	b[15:0] '1' for peripheral output, '0' for digital I/O
0x0048	PORT1_OUTPUT	b [15:0] Value to port 1 when it is an output.
0x004A	PORT1_INPUT	b [15:0] Read only value from Port 1.
0x004C	PORT1_TRISTATE	b [15:0] '1' for output, '0' for input.
0x004E	PORT1_MODE	b[15:0] '1' for peripheral output, '0' for digital I/O
0x0050	PORT2_OUTPUT	b [15:0] Value to port 2 when it is an output.
0x0052	PORT2_INPUT	b [15:0] Read only value from Port 2.
0x0054	PORT2_TRISTATE	b [15:0] '1' for output, '0' for input.
0x0056	PORT2_MODE	b[15:0] '1' for peripheral output, '0' for digital I/O
0x0058	STROBE_STATUS	b [9] STR2_TRI – '0' = strobe2 is input, '1' = strobe2 is output. b [8] STR1_TRI – '0' = strobe1 is input, '1' = strobe1 is output. b [5] STR2_OUT – Value for strobe2 when an output. b [4] STR1_OUT – Value for strobe1 when an output. b [1] STR2_IN – Current value of Strobe2. b [0] STR1_IN – Current value of Strobe1.
0x005A–0x005E	Reserved	
0x0060	PORT0_PERIPH_SEL_L	b[15:14] Port0[7]_Periph_Select b[13:12] Port0[6]_Periph_Select b[11:10] Port0[5]_Periph_Select b[9:8] Port0[4]_Periph_Select b[7:6] Port0[3]_Periph_Select b[5:4] Port0[2]_Periph_Select b[3:2] Port0[2]_Periph_Select b[1:0] Port0[0]_Periph_Select
0x0062	PORT0_PERIPH_SEL_H	b[15:14] Port0[15]_Periph_Select b[13:12] Port0[14]_Periph_Select b[11:10] Port0[13]_Periph_Select b[9:8] Port0[12]_Periph_Select b[7:6] Port0[11]_Periph_Select b[5:4] Port0[10]_Periph_Select b[3:2] Port0[9]_Periph_Select b[1:0] Port0[8]_Periph_Select
0x0064	PORT1_PERIPH_SEL_L	
0x0066	PORT1_PERIPH_SEL_H	
0x0068	PORT2_PERIPH_SEL_L	

Table 9: DMx820HR Memory Map

Offset (Hex)	Register Name	Register Function
0x006A	PORT2_PERIPH_SEL_H	
0x0070–0x007E	Reserved	
82C54 Timer Counter Control		
0x0080	TC_ID	b[15:0] ID Register – equals 0x1001
0x0082	TC_INT	b[15:14] Reserved b [13:8] Interrupt Status – ‘1’ = Interrupt condition has occurred. Write ‘1’ to clear. Interrupts are asserted on the positive edge of the clock. b[7:6] Reserved b[5:0] Interrupt Enable – ‘1’ = Interrupt is enabled, ‘0’ = disabled Interrupt source are: 5 TC B2 4 TC B1 3 TC B0 2 TC A2 1 TC A1 0 TC A0
0x0084	TC_A0_CONTROL	b[15:13] Reserved
0x0086	TC_A1_CONTROL	b[12:8] Gate Select
0x0088	TC_A2_CONTROL	31-16 = Port 2 [15-0]
0x008A	TC_B0_CONTROL	15-2 = Clock_Bus [15-2]
0x008C	TC_B1_CONTROL	1 = ‘1’ 0 = ‘0’
0x008E	TC_B2_CONTROL	b[7:4] Reserved b[3:0] Clock Select 15-2 = Clock_Bus [15-2] 1 = reserved 0 = 5 MHz
FIFO Channel 0		
0x00C0	FIFO0_ID	b[15:0] ID Register = 0x2011
0x00C2	FIFO0_INT	b [15:8] Interrupt Status – ‘1’ = Interrupt condition has occurred. Write ‘1’ to clear. b[7:0] Interrupt Enable – ‘1’ = Interrupt is enabled, ‘0’ = disabled Interrupt source are: 7 Reserved 6 Reserved 5 Underflow 4 Overflow 3 Empty 2 Full 1 Write Request 0 Read Request
0x00C4	FIFO0_IN_CLK	b[15:5] Reserved b[4:0] Input Clock Select 31 = PCI Write 30 = PCI Read 29-16 = Interrupts[13-0] 15-0 = Clock_Bus [15-0]
0x00C6	FIFO0_OUT_CLK	b[15:5] Reserved b[4:0] Input Clock Select 31 = PCI Write 30 = PCI Read 29-16 = Interrupts[13-0] 15-0 = Clock_Bus [15-0]

Table 9: DMx820HR Memory Map

Offset (Hex)	Register Name	Register Function
0x00C8	FIFO0_IN_DATA_DREQ	b[15:10] Reserved b[9:8] DREQ0 Source 3 = Not Full 2 = Write Request 1 = Not Empty 0 = Read Request b[7:4] Reserved b[3:0] Input Data Select 3 = FIFO0 Output 2 = Port 2 1 = Port 0 0 = PCI Data
0x00CA	FIFO0_CON_STAT	b[15:10] Reserved b[9] Write Request (non-sticky) b[8] Read Request (non-sticky) b[7:1] Reserved b[0] '1' = Enable, '0' = Clear
0x00CC	FIFO0_RW_PORT	b [15:0] Read/Write Port. (Word access only)
FIFO Channel 1		
0x00D0	FIFO1_ID	b[15:0] ID Register = 0x2011
0x00D2	FIFO1_INT	b [15:8] Interrupt Status – '1' = Interrupt condition has occurred. Write '1' to clear. b[7:0] Interrupt Enable – '1' = Interrupt is enabled, '0' = disabled Interrupt source are: 7 Reserved 6 Reserved 5 Underflow 4 Overflow 3 Empty 2 Full 1 Write Request 0 Read Request
0x00D4	FIFO1_IN_CLK	b[15:5] Reserved b[4:0] Input Clock Select 31 = PCI Write 30 = PCI Read 29-16 = Interrupts[13-0] 15-0 = Clock_Bus [15-0]
0x00D6	FIFO1_OUT_CLK	b[15:5] Reserved b[4:0] Input Clock Select 31 = PCI Write 30 = PCI Read 29-16 = Interrupts[13-0] 15-0 = Clock_Bus [15-0]
0x00D8	FIFO1_IN_DATA_DREQ	b[15:10] Reserved b[9:8] DREQ1 Source 3 = Not Full 2 = Write Request 1 = Not Empty 0 = Read Request b[7:4] Reserved b[3:0] Input Data Select 3 = Incremental Encoder B1 2 = Incremental Encoder B0 1 = Port 1 0 = PCI Data

Table 9: DMx820HR Memory Map

Offset (Hex)	Register Name	Register Function
0x00DA	FIFO1_CON_STAT	b[15:10] Reserved b[9] Write Request (non-sticky) b[8] Read Request (non-sticky) b[7:1] Reserved b[0] '1' = Enable, '0' = Clear
0x00DC	FIFO1_RW_PORT	b [15:0] Read/Write Port. (Word access only)
Programmable Clock 0		
0x0100	PRGCLK0_ID	b[15:0] ID Register = 0x1000
0x0102	PRGCLK0_MODE	b[15:2] Reserved b[1:0] '00' = Disabled '01' = Continuous '10' = Retrigger '11' = One-Shot
0x0104	PRGCLK0_CLK	b[15:4] Reserved b[3:0] Master Clock Source 15-0 = Clock_Bus [15-0]
0x0106	PRGCLK0_START_STOP	b[15:13] Reserved b[12:8] Stop Clock 31-16 = Interrupt_Bus[15-0] 15-1 = Clock_Bus [15-1] 0 = No Stop Clock b[7:5] Reserved b[4:0] Start Trigger 31-16 = Interrupt_Bus[15-0] 15-1 = Clock_Bus [15-1] 0 = Start Immediate
0x0108	PRGCLK0_PERIOD	b[15:0] Period of Clock Output frequency is: $\frac{\text{Master_Clock_Frequency}}{(\text{PRG_CLK_PERIOD} + 1)}$
0x010A	PRGCLK0_COUNT	b[15:0] The current value of the clock counter
Programmable Clock 1		
0x0140	PRGCLK1_ID	b[15:0] ID Register = 0x1000
0x0142	PRGCLK1_MODE	b[15:2] Reserved b[1:0] '00' = Disabled '01' = Continuous '10' = Retrigger '11' = One-Shot
0x0144	PRGCLK1_CLK	b[15:4] Reserved b[3:0] Master Clock Source 15-0 = Clock_Bus [15-0]
0x0146	PRGCLK1_START_STOP	b[15:13] Reserved b[12:8] Stop Clock 31-16 = Interrupt_Bus[15-0] 15-1 = Clock_Bus [15-1] 0 = No Stop Clock b[7:5] Reserved b[4:0] Start Trigger 31-16 = Interrupt_Bus[15-0] 15-1 = Clock_Bus [15-1] 0 = Start Immediate

Table 9: DMx820HR Memory Map

Offset (Hex)	Register Name	Register Function
0x0148	PRGCLK1_PERIOD	b[15:0] Period of Clock Output frequency is: <i>Master_Clock_Frequency</i> (PRG_CLK_PERIOD + 1)
0x014A	PRGCLK1_COUNT	b[15:0] The current value of the clock counter
Programmable Clock 2		
0x0180	PRGCLK2_ID	b[15:0] ID Register = 0x1000
0x0182	PRGCLK2_MODE	b[15:2] Reserved b[1:0] '00' = Disabled '01' = Continuous '10' = Retrigger '11' = One-Shot
0x0184	PRGCLK2_CLK	b[15:4] Reserved b[3:0] Master Clock Source 15-0 = Clock_Bus [15-0]
0x0186	PRGCLK2_START_STOP	b[15:13] Reserved b[12:8] Stop Clock 31-16 = Interrupt_Bus[15-0] 15-1 = Clock_Bus [15-1] 0 = No Stop Clock b[7:5] Reserved b[4:0] Start Trigger 31-16 = Interrupt_Bus[15-0] 15-1 = Clock_Bus [15-1] 0 = Start Immediate
0x0188	PRGCLK2_PERIOD	b[15:0] Period of Clock Output frequency is: <i>Master_Clock_Frequency</i> (PRG_CLK_PERIOD + 1)
0x018A	PRGCLK2_COUNT	b[15:0] The current value of the clock counter
Programmable Clock 3		
0x01C0	PRGCLK3_ID	b[15:0] ID Register = 0x1000
0x01C2	PRGCLK3_MODE	b[15:2] Reserved b[1:0] '00' = Disabled '01' = Continuous '10' = Retrigger '11' = One-Shot
0x01C4	PRGCLK3_SOURCE	b[15:4] Reserved b[3:0] Master Clock Source 15-0 = Clock_Bus [15-0]
0x01C6	PRGCLK3_START_STOP	b[15:13] Reserved b[12:8] Stop Clock 31-16 = Interrupt_Bus[15-0] 15-1 = Clock_Bus [15-1] 0 = No Stop Clock b[7:5] Reserved b[4:0] Start Trigger 31-16 = Interrupt_Bus[15-0] 15-1 = Clock_Bus [15-1] 0 = Start Immediate
0x01C8	PRGCLK3_PERIOD	b[15:0] Period of Clock Output frequency is: <i>Master_Clock_Frequency</i> (PRG_CLK_PERIOD + 1)

Table 9: DMx820HR Memory Map

Offset (Hex)	Register Name	Register Function
0x01CA	PRGCLK3_COUNT	b[15:0] The current value of the clock counter
Advanced Interrupt 0		
0x0200	ADVINT0_ID	b[15:0] ID Register = 0x0001
0x0202	ADVINT0_INT_MODE	b[1:0] Interrupt Mode 3 = Event Mode 2 = Match Mode 1 = Strobe Mode 0 = Disabled
0x0204	ADVINT0_CLK	b[3:0] Sample Clock Source 15-0 = Clock_Bus [15-0]
0x0206	Reserved	
0x0208	ADVINT0_PORT0_MASK	b[15:0] Port 0 Mask '0' = Bit is used for match/event '1' = Bit is ignored
0x020A	ADVINT0_PORT1_MASK	b[15:0] Port 1 Mask '0' = Bit is used for match/event '1' = Bit is ignored
0x020C	ADVINT0_PORT2_MASK	b[15:0] Port 2 Mask '0' = Bit is used for match/event '1' = Bit is ignored
0x020E	Reserved	
0x0210	ADVINT0_PORT0_CMP	b [15:0] Port 0 Compare – Value used for interrupt on match.
0x0212	ADVINT0_PORT1_CMP	b [15:0] Port 1 Compare – Value used for interrupt on match.
0x0214	ADVINT0_PORT2_CMP	b [15:0] Port 2 Compare – Value used for interrupt on match.
0x0216	Reserved	
0x0218	ADVINT0_PORT0_CAPT	b [15:0] Port 0 Capture – Value on Port 0 is written to this register when an interrupt occurs.
0x021A	ADVINT0_PORT1_CAPT	b [15:0] Port 1 Capture – Value on Port 1 is written to this register when an interrupt occurs.
0x021C	ADVINT0_PORT2_CAPT	b [15:0] Port 2 Capture – Value on Port 2 is written to this register when an interrupt occurs.
0x021E	Reserved	
Advanced Interrupt 1		
0x0240	ADVINT1_ID	b[15:0] ID Register = 0x0001
0x0242	ADVINT1_INT_MODE	b[1:0] Interrupt Mode 3 = Event Mode 2 = Match Mode 1 = Strobe Mode 0 = Disabled
0x0244	ADVINT1_CLK	b[3:0] Sample Clock Source 15-0 = Clock_Bus [15-0]
0x0246	Reserved	
0x0248	ADVINT1_PORT0_MASK	b[15:0] Port 0 Mask '0' = Bit is used for match/event '1' = Bit is ignored
0x024A	ADVINT1_PORT1_MASK	b[15:0] Port 1 Mask '0' = Bit is used for match/event '1' = Bit is ignored
0x024C	ADVINT1_PORT2_MASK	b[15:0] Port 2 Mask '0' = Bit is used for match/event '1' = Bit is ignored
0x024E	Reserved	
0x0250	ADVINT1_PORT0_CMP	b [15:0] Port 0 Compare – Value used for interrupt on match.
0x0252	ADVINT1_PORT1_CMP	b [15:0] Port 1 Compare – Value used for interrupt on match.
0x0254	ADVINT1_PORT2_CMP	b [15:0] Port 2 Compare – Value used for interrupt on match.

Table 9: DMx820HR Memory Map

Offset (Hex)	Register Name	Register Function
0x0256	Reserved	
0x0258	ADVINT1_PORT0_CAPT	b [15:0] Port 0 Capture – Value on Port 0 is written to this register when an interrupt occurs.
0x025A	ADVINT1_PORT1_CAPT	b [15:0] Port 1 Capture – Value on Port 1 is written to this register when an interrupt occurs.
0x025C	ADVINT1_PORT2_CAPT	b [15:0] Port 2 Capture – Value on Port 2 is written to this register when an interrupt occurs.
0x025E	Reserved	
Dual Incremental Encoder 0		
0x0280	INCENC0_ID	b[15:0] ID Register = 0x0002
0x0282	INCENC0_INT	b [11:8] Interrupt Status – ‘1’ = Interrupt condition has occurred. Write ‘1’ to clear. b[3:0] Interrupt Enable – ‘1’ = Interrupt is enabled, ‘0’ = disabled Interrupt source are: 3 Encoder B Negative Rollover 2 Encoder B Positive Rollover 1 Encoder A Negative Rollover 0 Encoder A Positive Rollover
0x0284	INCENC0_CLOCK	b[3:0] Master Clock Source 15-0 = Clock_Bus [15-0]
0x0286	INCENC0_MODE	b [15:8] Phase Filter – Writing a ‘1’ to a specific bit masks out a phase transition. b[7:6] Reserved b[5] Differential Mode ‘1’ = Pseudo differential mode, ‘0’ = Single ended mode b[4] Input Filter – ‘1’ = Enable Input Filter, ‘0’ = Disable Input Filter b [3] Join – ‘1’ = Operate as single 32-bit Encoder, ‘0’ = Operate as two 16-bit Encoders. b [2] ‘0’ = External Index is disabled, ‘1’ = External Index is enabled. b [1] Hold Register – ‘1’ = Hold values register, ‘0’ = Allow value register to change. b [0] Count Enable – ‘1’ = Encoder is enabled, ‘0’ = Encoder is cleared.
0x0288	INCENC0_VALUEA	b[15:0] Value for Encoder A
0x028A	INCENC0_VALUEB	b[15:0] Value for Encoder B
Dual Incremental Encoder 1		
0x02C0	INCENC1_ID	b[15:0] ID Register = 0x0002
0x02C2	INCENC1_INT	b [11:8] Interrupt Status – ‘1’ = Interrupt condition has occurred. Write ‘1’ to clear. b[3:0] Interrupt Enable – ‘1’ = Interrupt is enabled, ‘0’ = disabled Interrupt source are: 3 Encoder B Negative Rollover 2 Encoder B Positive Rollover 1 Encoder A Negative Rollover 0 Encoder A Positive Rollover
0x02C4	INCENC1_CLOCK	b[3:0] Master Clock Source 15-0 = Clock_Bus [15-0]

Table 9: DMx820HR Memory Map

Offset (Hex)	Register Name	Register Function
0x02C6	INCENC1_MODE	b [15:8] Phase Filter – Writing a ‘1’ to a specific bit masks out a phase transition. b[7:6] Reserved b[5] Differential Mode ‘1’ = Pseudo differential mode, ‘0’ = Single ended mode b[4] Input Filter – ‘1’ = Enable Input Filter, ‘0’ = Disable Input Filter b [3] Join – ‘1’ = Operate as single 32-bit Encoder, ‘0’ = Operate as two 16-bit Encoders. b [2] ‘0’ = External Index is disabled, ‘1’ = External Index is enabled. b [1] Hold Register – ‘1’ = Hold values register, ‘0’ = Allow value register to change. b[0] Count Enable – ‘1’ = Encoder is enabled, ‘0’ = Encoder is cleared.
0x02C8	INCENC1_VALUEA	b[15:0] Value for Encoder A
0x02CA	INCENC1_VALUEB	b[15:0] Value for Encoder B
Pulse Width Modulator 0		
0x0300	PWM0_ID	b[15:0] ID Register = 0x0003
0x0302	PWM0_MODE	b[0] ‘1’ = Enable PWM, ‘0’ = Disable PWM
0x0304	PWM0_CLK	b[7:4] Period Clock Source 15-0 = Clock_Bus [15-0] b[3:0] Width Clock Source 15-0 = Clock_Bus [15-0]
0x0306	Reserved	
0x0308	PWM0_PERIOD	b[15:0] Period of PWM Cycle is: $\frac{Width_Clock_Frequency}{(PWMx_PERIOD + 1)}$
0x030A-0x030E	Reserved	
0x0310	PWM0_WIDTHHA	b[15:0] Width of output A pulse in Period Clock cycles
0x0312	Reserved	
0x0314	PWM0_WIDTHHB	b[15:0] Width of output B pulse in Period Clock cycles
0x0316	Reserved	
0x0318	PWM0_WIDTHHC	b[15:0] Width of output C pulse in Period Clock cycles
0x031A	Reserved	
0x031C	PWM0_WIDTHHD	b[15:0] Width of output D pulse in Period Clock cycles
0x031E	Reserved	
Pulse Width Modulator 1		
0x0340	PWM1_ID	b[15:0] ID Register = 0x0003
0x0342	PWM1_MODE	b[0] ‘1’ = Enable PWM, ‘0’ = Disable PWM
0x0344	PWM1_CLK	b[7:4] Period Clock Source 15-0 = Clock_Bus [15-0] b[3:0] Width Clock Source 15-0 = Clock_Bus [15-0]
0x0346	Reserved	
0x0348	PWM1_PERIOD	b[15:0] Period of PWM Cycle is: $\frac{Width_Clock_Frequency}{(PWMx_PERIOD + 1)}$
0x034A-0x034E	Reserved	
0x0350	PWM1_WIDTHHA	b[15:0] Width of output A pulse in Period Clock cycles

Table 9: DMx820HR Memory Map

Offset (Hex)	Register Name	Register Function
0x0352	Reserved	
0x0354	PWM1_WIDTHHB	b[15:0] Width of output B pulse in Period Clock cycles
0x0356	Reserved	
0x0358	PWM1_WIDTHHC	b[15:0] Width of output C pulse in Period Clock cycles
0x035A	Reserved	
0x035C	PWM1_WIDTHHD	b[15:0] Width of output D pulse in Period Clock cycles
0x035E	Reserved	
82C54 Timer Counter A		
0x1000	TCA_COUNTER_0	b[7:0] Counter 0 Register
0x1004	TCA_COUNTER_1	b[7:0] Counter 1 Register
0x1008	TCA_COUNTER_2	b[7:0] Counter 2 Register
0x100C	TCA_CON_WORD	b[7:0] Control Word Register
82C54 Timer Counter B		
0x1010	TCB_COUNTER_0	b[7:0] Counter 0 Register
0x1014	TCB_COUNTER_1	b[7:0] Counter 1 Register
0x1018	TCB_COUNTER_2	b[7:0] Counter 2 Register
0x101C	TCB_CON_WORD	b[7:0] Control Word Register

6.3 Detailed Register Description

The following sections provide a detailed description of the individual registers. In the following register description sections, each register is described by a register table. The first row of the table lists the bits, D15 through D0. The second row lists the field name for each bit. The third row lists the properties of that bit; 'R' = bit can be read, 'W' = bit can be written to, and 'C' = bit can be cleared. The last row lists the value of the bit after reset. The register table is then followed by a description of each of the fields where applicable. An "N/A" for the reset value indicates that the reset value is not applicable - read the field descriptions for more information.

Bits marked as "Reserved" in the field name are unused, and reads will always return their reset value. These bits should not be modified during writes for future compatibility.

6.3.1 SYSTEM BLOCK

FPGA_VERSION

This register provides the version and type ID of the Digital I/O FPGA. The version can be used to identify the specific build of the board. The type ID can be used to identify a particular feature set.

15	8 7	0
TYPE_ID	VERSION	
R,+xxxx xxxx	R, +xxxx xxxx	

Field	Description
TYPE_ID	FPGA Type Identifier. 0x10 = Standard FPGA
VERSION	FPGA Version Identifier

SVN_VERSION

This register provides the source code revision control version. It is updated every time the FPGA is compiled.

15	0
VERSION	
R,+xxxx xxxx xxxx xxxx	

Field	Description
VERSION	FPGA Source Version Identifier

BOARD_RESET

Writing a value of 0xA5A5 to this register resets the board. All internal registers are set to their default values.

Note: The 82C54 Timer/Counters are not affected by this register

15	RESET	0
	W,+0000 0000 0000 0000	

Field	Description
RESET	Write 0xA5A5 to reset the board. All other writes are ignored. Reads will return all zeros.

BRD_STAT

This register contains status information for the board.

15	Reserved	1	0
	R,+0		MSTR
			R,+N

Field	Description
MSTR	Indicates if the board is PCI master capable based on the rotary switch and jumper settings. '0' = PCI Master '1' = Not PCI Master

INT_ENABLE

This register controls which interrupt sources are used to generate a local interrupt.

15	14	13	12	11	10	9	8
FIFO1	FIFO0	PClk3	PClk2	PClk1	PClk0	PWM1	PWM0
RW,+0	RW,+0	RW,+0	RW,+0	RW,+0	RW,+0	RW,+0	RW,+0

7	6	5	4	3	2	1	0
Reserved	IncEnc1	IncEnc0	Rsvd	82C54	AdvInt1	AdvInt0	AdvInt0
R,+00	RW,+0	RW,+0	R,+0	RW,+0	RW,+0	RW,+0	RW,+0

Field	Description
AdvInt0	Interrupt from Advance Interrupt block at 0x0200 '0' = Interrupt Disabled '1' = Interrupt Enabled
AdvInt1	Interrupt from Advance Interrupt block at 0x0240 '0' = Interrupt Disabled '1' = Interrupt Enabled
82C54	Interrupt 82C54 Timer/Counter block at 0x0080 '0' = Interrupt Disabled '1' = Interrupt Enabled

IncEnc0	Interrupt from Incremental Encoder block at 0x0280 '0' = Interrupt Disabled '1' = Interrupt Enabled
IncEnc1	Interrupt from Incremental Encoder block at 0x02C0 '0' = Interrupt Disabled '1' = Interrupt Enabled
PWM0	Interrupt from Pulse Width Modulator block at 0x0300 '0' = Interrupt Disabled '1' = Interrupt Enabled
PWM1	Interrupt from Pulse Width Modulator block at 0x0340 '0' = Interrupt Disabled '1' = Interrupt Enabled
PClk0	Interrupt from Programmable Clock block at 0x0100 '0' = Interrupt Disabled '1' = Interrupt Enabled
PClk1	Interrupt from Programmable Clock block at 0x0140 '0' = Interrupt Disabled '1' = Interrupt Enabled
PClk2	Interrupt from Programmable Clock block at 0x0180 '0' = Interrupt Disabled '1' = Interrupt Enabled
PClk3	Interrupt from Programmable Clock block at 0x01C0 '0' = Interrupt Disabled '1' = Interrupt Enabled
FIFO0	Interrupt from FIFO block at 0x00C0 '0' = Interrupt Disabled '1' = Interrupt Enabled
FIFO1	Interrupt from FIFO block at 0x00D0 '0' = Interrupt Disabled '1' = Interrupt Enabled

INT_STATUS

This register shows if any of the interrupt conditions has occurred. This is a sticky register – bits remain set until cleared by writing a '1'. Interrupts do not have to be enabled in INT_ENABLE in order for status bits to be set.

15	14	13	12	11	10	9	8
FIFO1	FIFO0	PClk3	PClk2	PClk1	PClk0	PWM1	PWM0
RC,+0	RC,+0	RC,+0	RC,+0	RC,+0	RC,+0	RC,+0	RC,+0
7	6	5	4	3	2	1	0
Reserved	IncEnc1	IncEnc0	Rsvd	82C54	AdvInt1	AdvInt0	
R,+0	RC,+0	RC,+0	R,+0	RC,+0	RC,+0	RC,+0	RC,+0

Field	Description
AdvInt0	Interrupt from Advance Interrupt block at 0x0200 '0' = Interrupt has not occurred '1' = Interrupt has occurred. Write '1' to clear.
AdvInt1	Interrupt from Advance Interrupt block at 0x0240 '0' = Interrupt has not occurred '1' = Interrupt has occurred. Write '1' to clear.
82C54	Interrupt 82C54 Timer/Counter block at 0x0080 '0' = Interrupt has not occurred '1' = Interrupt has occurred. Write '1' to clear.
IncEnc0	Interrupt from Incremental Encoder block at 0x0280 '0' = Interrupt has not occurred '1' = Interrupt has occurred. Write '1' to clear.
IncEnc1	Interrupt from Incremental Encoder block at 0x02C0

	'0' = Interrupt has not occurred '1' = Interrupt has occurred. Write '1' to clear.
PWM0	Interrupt from Pulse Width Modulator block at 0x0300 '0' = Interrupt has not occurred '1' = Interrupt has occurred. Write '1' to clear.
PWM1	Interrupt from Pulse Width Modulator block at 0x0340 '0' = Interrupt has not occurred '1' = Interrupt has occurred. Write '1' to clear.
PClk0	Interrupt from Programmable Clock block at 0x0100 '0' = Interrupt has not occurred '1' = Interrupt has occurred. Write '1' to clear.
PClk1	Interrupt from Programmable Clock block at 0x0140 '0' = Interrupt has not occurred '1' = Interrupt has occurred. Write '1' to clear.
PClk2	Interrupt from Programmable Clock block at 0x0180 '0' = Interrupt has not occurred '1' = Interrupt has occurred. Write '1' to clear.
PClk3	Interrupt from Programmable Clock block at 0x01C0 '0' = Interrupt has not occurred '1' = Interrupt has occurred. Write '1' to clear.
FIFO0	Interrupt from FIFO block at 0x00C0 '0' = Interrupt has not occurred '1' = Interrupt has occurred. Write '1' to clear.
FIFO1	Interrupt from FIFO block at 0x00D0 '0' = Interrupt has not occurred '1' = Interrupt has occurred. Write '1' to clear.

6.3.2 STANDARD I/O

A diagram of the standard I/O is shown in Figure 10. Each digital I/O pin can be an input, output, or peripheral output. The peripheral outputs are the Pulse Width Modulators, FIFO, Timer/Counters, etc.

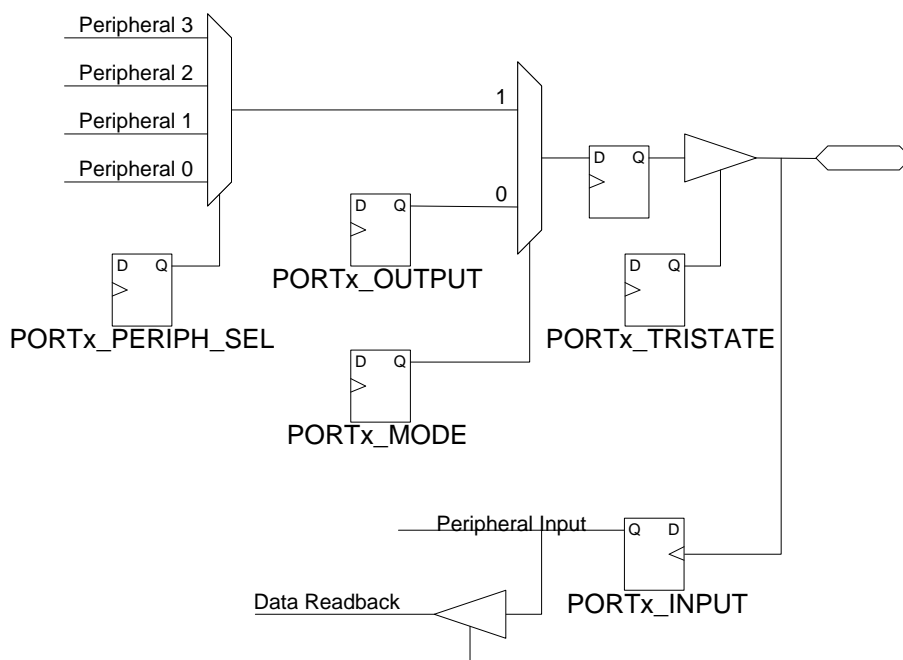

Figure 10: Digital I/O Block Diagram

PORTx OUTPUT

Sets the value for Port 0, Port 1, or Port 2 when it is a standard output.

15	14	13	12	11	10	9	8
Px_15	Px_14	Px_13	Px_12	Px_11	Px_10	Px_9	Px_8
RW,+0	RW,+0	RW,+0	RW,+0	RW,+0	RW,+0	RW,+0	RW,+0

7	6	5	4	3	2	1	0
Px_7	Px_6	Px_5	Px_4	Px_3	Px_2	Px_1	Px_0
RW,+0	RW,+0	RW,+0	RW,+0	RW,+0	RW,+0	RW,+0	RW,+0

Field	Description
Px_[15:0]	Value to output '0' = Low '1' = High

PORTx INPUT

Returns the current value of Port 0, Port 1, or Port 2.

15	14	13	12	11	10	9	8
Px_15	Px_14	Px_13	Px_12	Px_11	Px_10	Px_9	Px_8
R,+0	R,+0	R,+0	R,+0	R,+0	R,+0	R,+0	R,+0

7	6	5	4	3	2	1	0
Px_7	Px_6	Px_5	Px_4	Px_3	Px_2	Px_1	Px_0
R,+0	R,+0	R,+0	R,+0	R,+0	R,+0	R,+0	R,+0

Field	Description
Px_[15:0]	Current pin value '0' = Pin is Low '1' = Pin is High

PORTx TRISTATE

This register selects if each bit in Port 0, Port 1, or Port 2 is an input or an output.

15	14	13	12	11	10	9	8
Px_15	Px_14	Px_13	Px_12	Px_11	Px_10	Px_9	Px_8
RW,+0	RW,+0	RW,+0	RW,+0	RW,+0	RW,+0	RW,+0	RW,+0

7	6	5	4	3	2	1	0
Px_7	Px_6	Px_5	Px_4	Px_3	Px_2	Px_1	Px_0
RW,+0	RW,+0	RW,+0	RW,+0	RW,+0	RW,+0	RW,+0	RW,+0

Field	Description
Px_[15:0]	Select input or output '0' = Input '1' = Output

PORTx MODE

Selects if each pin in Port 0, Port 1, or Port 2 is a standard I/O (controlled by PORTx_TRISTATE) or a peripheral output (controlled by PORTx_PERIPH_SEL).

15	14	13	12	11	10	9	8
Px_15	Px_14	Px_13	Px_12	Px_11	Px_10	Px_9	Px_8
RW,+0	RW,+0	RW,+0	RW,+0	RW,+0	RW,+0	RW,+0	RW,+0

7	6	5	4	3	2	1	0
Px_7	Px_6	Px_5	Px_4	Px_3	Px_2	Px_1	Px_0
RW,+0	RW,+0	RW,+0	RW,+0	RW,+0	RW,+0	RW,+0	RW,+0

Field	Description
Px_[15:0]	Port Mode '0' = Standard I/O (controlled by PORTx_TRISTATE) '1' = Peripheral (controlled by PORTx_PERIPH_SEL)

PORTx PERIPH SEL_L

This register selects the peripheral for Port 0, Port 1, or Port 2 when it is a peripheral output (i.e. PORTx_MODE[] = '1'). This register selects the peripheral for bits [7:0].

15	14	13	12	11	10	9	8
Px_7	Px_6	Px_5	Px_4	Px_3	Px_2	Px_1	Px_0
RW,+00	RW,+00	RW,+00	RW,+00	RW,+00	RW,+00	RW,+00	RW,+00

7	6	5	4	3	2	1	0
Px_3	Px_2	Px_1	Px_0	Px_0	Px_0	Px_0	Px_0
RW,+00	RW,+00	RW,+00	RW,+00	RW,+00	RW,+00	RW,+00	RW,+00

PORTx PERIPH SEL_H

This register selects the peripheral for Port 0, Port 1, or Port 2 when it is a peripheral output (i.e. PORTx_MODE[] = '1'). This register selects the peripheral for bits [15:8].

15	14	13	12	11	10	9	8
Px_15	Px_14	Px_13	Px_12	Px_11	Px_10	Px_9	Px_8
RW,+00	RW,+00	RW,+00	RW,+00	RW,+00	RW,+00	RW,+00	RW,+00

7	6	5	4	3	2	1	0
Px_11	Px_10	Px_9	Px_8	Px_7	Px_6	Px_5	Px_4
RW,+00	RW,+00	RW,+00	RW,+00	RW,+00	RW,+00	RW,+00	RW,+00

Table 10: Peripheral Outputs

Pin	PORTx_PERIPH_SEL			
	00	01	10	11
Port0[0]			FIFO0_Out[0]	FIFO1_Out[0]
Port0[1]			FIFO0_Out[1]	FIFO1_Out[1]
Port0[2]			FIFO0_Out[2]	FIFO1_Out[2]
Port0[3]			FIFO0_Out[3]	FIFO1_Out[3]
Port0[4]			FIFO0_Out[4]	FIFO1_Out[4]
Port0[5]			FIFO0_Out[5]	FIFO1_Out[5]
Port0[6]			FIFO0_Out[6]	FIFO1_Out[6]
Port0[7]			FIFO0_Out[7]	FIFO1_Out[7]
Port0[8]			FIFO0_Out[8]	FIFO1_Out[8]
Port0[9]			FIFO0_Out[9]	FIFO1_Out[9]
Port0[10]			FIFO0_Out[10]	FIFO1_Out[10]
Port0[11]			FIFO0_Out[11]	FIFO1_Out[11]
Port0[12]			FIFO0_Out[12]	FIFO1_Out[12]
Port0[13]			FIFO0_Out[13]	FIFO1_Out[13]

Table 10: Peripheral Outputs

Pin	PORTx_PERIPH_SEL			
	00	01	10	11
Port0[14]			FIFO0_Out[14]	FIFO1_Out[14]
Port0[15]			FIFO0_Out[15]	FIFO1_Out[15]
Port1[0]			FIFO0_Out[0]	FIFO1_Out[0]
Port1[1]			FIFO0_Out[1]	FIFO1_Out[1]
Port1[2]			FIFO0_Out[2]	FIFO1_Out[2]
Port1[3]			FIFO0_Out[3]	FIFO1_Out[3]
Port1[4]			FIFO0_Out[4]	FIFO1_Out[4]
Port1[5]			FIFO0_Out[5]	FIFO1_Out[5]
Port1[6]	FIFO0_Empty		FIFO0_Out[6]	FIFO1_Out[6]
Port1[7]	FIFO1_Empty		FIFO0_Out[7]	FIFO1_Out[7]
Port1[8]			FIFO0_Out[8]	FIFO1_Out[8]
Port1[9]			FIFO0_Out[9]	FIFO1_Out[9]
Port1[10]			FIFO0_Out[10]	FIFO1_Out[10]
Port1[11]			FIFO0_Out[11]	FIFO1_Out[11]
Port1[12]			FIFO0_Out[12]	FIFO1_Out[12]
Port1[13]			FIFO0_Out[13]	FIFO1_Out[13]
Port1[14]			FIFO0_Out[14]	FIFO1_Out[14]
Port1[15]			FIFO0_Out[15]	FIFO1_Out[15]
Port2[0]	PWM0_A+		FIFO0_Out[0]	FIFO1_Out[0]
Port2[1]	PWM0_A-		FIFO0_Out[1]	FIFO1_Out[1]
Port2[2]	PWM0_B+	TC_A0_OUT	FIFO0_Out[2]	FIFO1_Out[2]
Port2[3]	PWM0_B-	TC_A1_OUT	FIFO0_Out[3]	FIFO1_Out[3]
Port2[4]	PWM0_C+	TC_A2_OUT	FIFO0_Out[4]	FIFO1_Out[4]
Port2[5]	PWM0_C-	TC_B0_OUT	FIFO0_Out[5]	FIFO1_Out[5]
Port2[6]	PWM0_D+	TC_B1_OUT	FIFO0_Out[6]	FIFO1_Out[6]
Port2[7]	PWM0_D-	TC_B2_OUT	FIFO0_Out[7]	FIFO1_Out[7]
Port2[8]	PWM1_A+	ProgClk0_OUT	FIFO0_Out[8]	FIFO1_Out[8]
Port2[9]	PWM1_A-	ProgClk1_OUT	FIFO0_Out[9]	FIFO1_Out[9]
Port2[10]	PWM1_B+	ProgClk2_OUT	FIFO0_Out[10]	FIFO1_Out[10]
Port2[11]	PWM1_B-	ProgClk3_OUT	FIFO0_Out[11]	FIFO1_Out[11]
Port2[12]	PWM1_C+	Strobe1_pos	FIFO0_Out[12]	FIFO1_Out[12]
Port2[13]	PWM1_C-	Strobe2_pos	FIFO0_Out[13]	FIFO1_Out[13]
Port2[14]	PWM1_D+	Strobe1_neg	FIFO0_Out[14]	FIFO1_Out[14]
Port2[15]	PWM1_D-	Strobe2_neg	FIFO0_Out[15]	FIFO1_Out[15]

STROBE STATUS

This register can be used to check the status of the strobe signals, as well as configure the strobes as outputs.

15	10	9	8
Reserved		STR2_TRI	STR1_TRI
R,+0000 00		RW,+0	RW,+0

7	6	5	4	3	2	1	0
Reserved	STR2_OUT	STR1_OUT	Reserved	Reserved	STR2_IN	STR1_IN	STR1_IN
R,+00	RW,+0	RW,+0	R,+00	R,+00	R,+x	R,+x	R,+x

Field	Description
STR1_IN	Current State of Strobe 1 '0' = Low '1' = High
STR2_IN	Current State of Strobe 2 '0' = Low '1' = High
STR1_OUT	Value to drive on Strobe 1 when an output '0' = Low '1' = High

Field	Description
STR2_OUT	Value to drive on Strobe 2 when an output '0' = Low '1' = High
STR1_TRI	Selects Input or Output for strobe 1 '0' = Input '1' = Output
STR2_TRI	Selects Input or Output for strobe 2 '0' = Input '1' = Output

6.3.3 82C54 TIMER COUNTER CONTROL

The Timer/Counter Control section is used to select the clock, gates and interrupt sources for the 82C54 Timer/Counters. The actual Timer/Counter registers are found in the 82C54 Timer Counter n section on page 58.

TC_ID

ID register to identify the Timer/Counter Block.

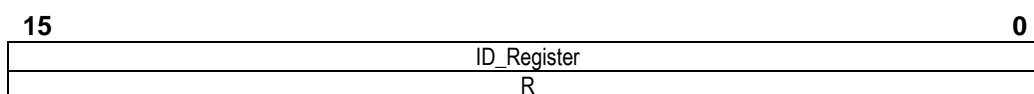

Field	Description
ID_Register[15:0]	Value of 0x1001 indicates Timer Counter Control Block

TC_INT

Enable and status for the interrupts generated by the 82C54 Timer Counters

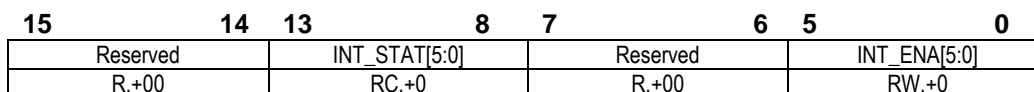

Field	Description
INT_STAT[5:0]	Interrupt Status – '1' = Interrupt condition has occurred. Write '1' to clear. Interrupts are asserted on the positive edge of the clock.
INT_ENA[5:0]	Interrupt Enable – '1' = Interrupt is enabled, '0' = disabled Interrupt source are: 5 TC B2 4 TC B1 3 TC B0 2 TC A2 1 TC A1 0 TC A0

TC_xy CONTROL

This register selects the input clock and gate source for the 82C54 Timer Counters. Note that the maximum input frequency to the Timer/Counters is 10 MHz. Also, no provision is made in hardware to prevent a Timer/Counter from using its own output clock as its input clock.

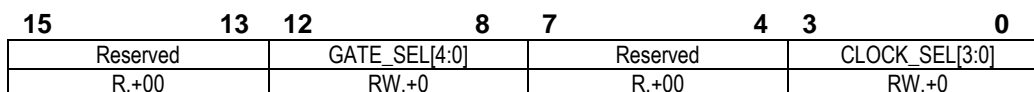

Field	Description
-------	-------------

Field	Description
GATE_SEL[4:0]	<p>Selects the gate input to this channel of the Timer/ Counter. Value definitions are:</p> <ul style="list-style-type: none"> 31 Port2[15] ... 16 Port2[0] 15 Inverted Strobe2 14 Inverted Strobe1 13 Strobe2 12 Strobe1 11 Prog. Clock 3 10 Prog. Clock 2 9 Prog. Clock 1 8 Prog. Clock 0 7 82C54 TC B2 6 82C54 TC B1 5 82C54 TC B0 4 82C54 TC A2 3 82C54 TC A1 2 82C54 TC A0 1 '1' 0 '0'
CLOCK_SEL[3:0]	<p>Selects the clock input to this channel of the Timer/ Counter. Value definitions are:</p> <ul style="list-style-type: none"> 15 Inverted Strobe2 14 Inverted Strobe1 13 Strobe2 12 Strobe1 11 Prog. Clock 3 10 Prog. Clock 2 9 Prog. Clock 1 8 Prog. Clock 0 7 82C54 TC B2 6 82C54 TC B1 5 82C54 TC B0 4 82C54 TC A2 3 82C54 TC A1 2 82C54 TC A0 1 Reserved 0 5 MHz

6.3.4 FIFO CHANNEL N

The DMx820HR provides two FIFOs to buffer data going into and out of the board. Each FIFO is 4MB in size. The input strobe, output strobe, and data input for each FIFO can be individually selected. The output data is made available to the peripheral outputs, and also the PCI interface.

Each FIFO is attached to a DMA Channel in the PLX chip. FIFO0 is attached to DMA0, and FIFO1 is attached to DMA1.

FIFO_n_ID

ID register to identify a FIFO Block.

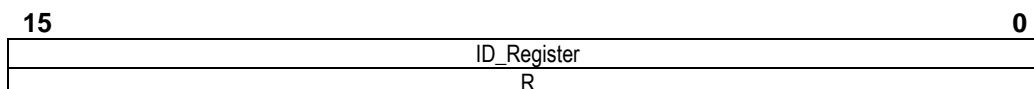

Field	Description
ID_Register[15:0]	Value of 0x2011 indicates SDRAM/FIFO Block

FIFO_n_INT

Enable and status for the interrupts generated by the FIFOs. An Overflow condition occurs when the FIFO is full, and it is written to. It can also occur when the FIFO is written to too fast. An Underflow occurs when the FIFO is empty and the output clock toggles, or when the FIFO is read from too fast. When the FIFO is disabled, the “Full,” “Empty,” and both requests are asserted.

15	8	7	0
INT_STAT[7:0]		INT_ENA[7:0]	
RC,+0		RW,+0	

Field	Description
INT_STAT[7:0]	Interrupt Status – ‘1’ = Interrupt condition has occurred. Write ‘1’ to clear. Interrupts are asserted on the positive edge of the clock.
INT_ENA[7:0]	Interrupt Enable – ‘1’ = Interrupt is enabled, ‘0’ = disabled Interrupt source are: 7 Reserved 6 Reserved 5 Underflow 4 Overflow 3 Empty 2 Full 1 Write Request 0 Read Request

FIFO_n_IN_CLK

This register selects the input clock to the FIFO. At every positive edge of the input clock, a word is read into the FIFO from the input source.

15	5	4	0
Reserved		CLOCK_SEL[4:0]	
R,+0		RW,+0	

Field	Description
CLOCK_SEL[4:0]	Selects the input clock input to this FIFO channel. Value definitions are: 31 PCI Write to FIFO _n _RW_PORT 30 PCI Read from FIFO _n _RW_PORT 29 Prog. Clock 3 Interrupt 28 Prog. Clock 2 Interrupt 27 Prog. Clock 1 Interrupt 26 Prog. Clock 0 Interrupt 25 PWM1 Interrupt 24 PWM0 Interrupt 23 Reserved 22 Reserved 21 Incremental Encoder 1 Interrupt 20 Incremental Encoder 0 Interrupt 19 Reserved 18 82C54 Interrupt 17 Advanced Interrupt 1 Interrupt 16 Advanced Interrupt 0 Interrupt 15 Inverted Strobe2 14 Inverted Strobe1 13 Strobe2 12 Strobe1 11 Prog. Clock 3 10 Prog. Clock 2 9 Prog. Clock 1 8 Prog. Clock 0 7 82C54 TC B2 6 82C54 TC B1

Field	Description
5	82C54 TC B0
4	82C54 TC A2
3	82C54 TC A1
2	82C54 TC A0
1	Reserved
0	25 MHz

FIFO_n OUT_CLK

This register selects the output clock to the FIFO. At every positive edge of the output clock, a new word available at the FIFO output.

15	Reserved	5	4	0
	R,+0			CLOCK_SEL[4:0] RW,+0

Field	Description
CLOCK_SEL[4:0]	<p>Selects the input clock input to this FIFO channel. Value definitions are:</p> <ul style="list-style-type: none"> 31 PCI Write to FIFO_n_RW_PORT 30 PCI Read from FIFO_n_RW_PORT 29 Prog. Clock 3 Interrupt 28 Prog. Clock 2 Interrupt 27 Prog. Clock 1 Interrupt 26 Prog. Clock 0 Interrupt 25 PWM1 Interrupt 24 PWM0 Interrupt 23 Reserved 22 Reserved 21 Incremental Encoder 1 Interrupt 20 Incremental Encoder 0 Interrupt 19 Reserved 18 82C54 Interrupt 17 Advanced Interrupt 1 Interrupt 16 Advanced Interrupt 0 Interrupt 15 Inverted Strobe2 14 Inverted Strobe1 13 Strobe2 12 Strobe1 11 Prog. Clock 3 10 Prog. Clock 2 9 Prog. Clock 1 8 Prog. Clock 0 7 82C54 TC B2 6 82C54 TC B1 5 82C54 TC B0 4 82C54 TC A2 3 82C54 TC A1 2 82C54 TC A0 1 Reserved 0 25 MHz

FIFO_n IN_DATA_DREQ

This register selects the FIFO data input and PLX DMA Request source. For the "Write Request" and "Read Request" signals, internal buffers are monitored to signal when data can be sent into, and read from the FIFO. The "Write Request" is asserted when there are at least 256 words of space available in the FIFO, and negated when there are less than 128 words available. The "Read Request" is asserted when at least 256 words of data is in the FIFO, and negated when there is less than 128 words of data. Using these signals guarantees a burst of at least 128 words, which provides for efficient communication over the PCI bus, and robustly guards against over-run and under-run conditions. However, it does not allow for the FIFO to be completely filled or emptied.

The "Not Full" and "Not Empty" request source should only be used if the amount of data in the FIFO is known, or to finish filling/emptying the FIFO. The DMA engine on the PLX PCI9056 will complete an additional double-word transfer after the request is negated. Therefore, using the "Not Full" and "Not Empty" request source will generally result in an over-run/under-run condition whenever the signal is negated.

The DREQ signals are in an undefined state when the FIFO is disabled. The DMA engine should only be enabled after the FIFO is enabled (FIFO_n_CON_STAT[ENA]).

15	10	9	8	7	2	1	0
Reserved		DREQ_SRC[1:0]		Reserved		IN_DATA[1:0]	
R,+0		RW,+0		R,+0		RW,+0	

Field	Description
DREQ_SRC[1:0]	Selects the source for the DREQ _n signal to the PLX chip. Value definitions are: 3 = Not Full 2 = Write Request 1 = Not Empty 0 = Read Request
IN_DATA[1:0]	Selects the FIFO Input Data. Value definitions for FIFO0 are: 3 = FIFO0 Output 2 = Port 2 1 = Port 0 0 = PCI Data Value definitions for FIFO1 are: 3 = Incremental Encoder 1 Channel B Value 2 = Incremental Encoder 1 Channel A Value 1 = Port 1 0 = PCI Data

FIFO_n CON_STAT

This register is used to enable the FIFO. When the FIFO is disabled, it is internally reset, and all data is flushed from it.

This register also is used to read the current status of the "Write Request" and "Read Request" signals that are used for DMA Requests. For these signals, internal buffers are monitored to signal when data can be sent into, and read from the FIFO. The "Write Request" is asserted when there are at least 256 words of space available in the FIFO, and negated when there are less than 128 words available. The "Read Request" is asserted when at least 256 words of data is in the FIFO, and negated when there is less than 128 words of data. Using these signals guarantees a burst of at least 128 words, which provides for efficient communication over the PCI bus, and robustly guards against over-run and under-run conditions. However, it does not allow for the FIFO to be completely filled or emptied.

15	10	9	8	7	1	0
Reserved		WRITE_REQ	READ_REQ	Reserved		ENA
R,+0		R,+x	R,+0	R,+0		RW,+0

Field	Description
WRITE_REQ	Current Write Request Status. '0' = Not ready to receive data '1' = Ready to receive data.
READ_REQ	Current Read Request Status. '0' = Not ready to send data '1' = Ready to send data.
ENA	FIFO Enable. '0' = FIFO is disabled and cleared '1' = FIFO is enabled.

FIFO_n RW_PORT

This register provides the PCI bus access to the FIFO. Reads from this register return the current data that is available at the output of the FIFO, and can be programmed to clock the next data out of the FIFO. Writes to this register can be programmed to write data into the FIFO.

Accesses to this register must be word (16-bit) or larger.

15	DATA[15:0]	0
	RW,+0	

Field	Description
DATA	The read or write data to the FIFO.

6.3.5 PROGRAMMABLE CLOCK N

There are four programmable clocks on the DMx820HR. They can be cascaded. The Programmable Clocks use a master clock and divide it down by an integer,

An interrupt is generated at every positive edge of the clock output.

PROGCLKn_ID

ID register to identify a Programmable Clock Block.

15	ID_Register	0
	R	

Field	Description
ID_Register[15:0]	Value of 0x1000 indicates Programmable Clock

PROGCLKn_MODE

Selects the mode that the Programmable Clock.

15	2	1	0
Reserved	MODE		
RW,+0	RW,+00		

Field	Description
MODE	Selects continuous or one-shot mode. The clock must be disabled when transitioning between modes. '00' = Disabled '01' = Continuous -The clock will generate a pulse train with the specified period. After the Stop Trigger, it will not retrigger. '10' = Retrigger - The clock will generate a pulse train with the specified period. After the Stop Trigger, it will wait for another Start Trigger. '11' = One-Shot – The clock will generate a single pulse one period time after it is started. Must be disabled and re-enabled to produce a second pulse.

PRGCLKn_CLK

This register selects the master clock for the programmable clock. The clock should be disabled before modifying this register.

15	4	3	0
Reserved	CLOCK_SEL[3:0]		
R,+0	RW,+0		

Field	Description
CLOCK_SEL[3:0]	Selects the master clock. Value definitions are: 15 Inverted Strobe2 14 Inverted Strobe1

Field	Description
	13 Strobe2
	12 Strobe1
	11 Prog. Clock 3
	10 Prog. Clock 2
	9 Prog. Clock 1
	8 Prog. Clock 0
	7 82C54 TC B2
	6 82C54 TC B1
	5 82C54 TC B0
	4 82C54 TC A2
	3 82C54 TC A1
	2 82C54 TC A0
	1 Reserved
	0 25 MHz

PRGCLKn_START_STOP

This register selects the Start and Stop Trigger for the programmable clock. The clock will not begin generating an output until the first positive edge of the Start Trigger. The first edge of the programmable clock output will occur one period after the Start Trigger edge. If in continuous mode, the clock will continue to run until the first edge of the Stop Trigger. After the clock has stopped, it must be disabled and re-enabled for it to start again if in Continuous mode. The clock should be disabled before modifying this register.

15	13	12	8	7	5	4	0
Reserved	STOP_TRG[4:0]		Reserved		START_TRG[4:0]		
R,+0	RW,+0		R,+0		RW,+0		

Field	Description
START_TRG[4:0]	Selects the start trigger. Value definitions are: 31 FIFO1 Interrupt 30 FIFO0 Interrupt 29 Prog. Clock 3 Interrupt 28 Prog. Clock 2 Interrupt 27 Prog. Clock 1 Interrupt 26 Prog. Clock 0 Interrupt 25 PWM1 Interrupt 24 PWM0 Interrupt 23 Reserved 22 Reserved 21 Incremental Encoder 1 Interrupt 20 Incremental Encoder 0 Interrupt 19 Reserved 18 82C54 Interrupt 17 Advanced Interrupt 1 Interrupt 16 Advanced Interrupt 0 Interrupt 15 Inverted Strobe2 14 Inverted Strobe1 13 Strobe2 12 Strobe1 11 Prog. Clock 3 10 Prog. Clock 2 9 Prog. Clock 1 8 Prog. Clock 0 7 82C54 TC B2 6 82C54 TC B1 5 82C54 TC B0 4 82C54 TC A2 3 82C54 TC A1 2 82C54 TC A0 1 Reserved 0 Start Immediate

Field	Description
STOP_TRG[4:0]	Selects the stop trigger. Value definitions are: 31 FIFO1 Interrupt 30 FIFO0 Interrupt 29 Prog. Clock 3 Interrupt 28 Prog. Clock 2 Interrupt 27 Prog. Clock 1 Interrupt 26 Prog. Clock 0 Interrupt 25 PWM1 Interrupt 24 PWM0 Interrupt 23 Reserved 22 Reserved 21 Incremental Encoder 1 Interrupt 20 Incremental Encoder 0 Interrupt 19 Reserved 18 82C54 Interrupt 17 Advanced Interrupt 1 Interrupt 16 Advanced Interrupt 0 Interrupt 15 Inverted Strobe2 14 Inverted Strobe1 13 Strobe2 12 Strobe1 11 Prog. Clock 3 10 Prog. Clock 2 9 Prog. Clock 1 8 Prog. Clock 0 7 82C54 TC B2 6 82C54 TC B1 5 82C54 TC B0 4 82C54 TC A2 3 82C54 TC A1 2 82C54 TC A0 1 Reserved 0 Do Not Stop

PROGCLn_PERIOD

Sets the period of the programmable clock.

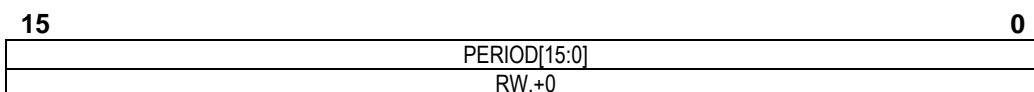

Field	Description
PERIOD[15:0]	The frequency of the output clock is: $\frac{\text{Master_Clock_Frequency}}{(\text{PERIOD} + 1)}$

PROGCLn_COUNT

The current value of the clock counter.

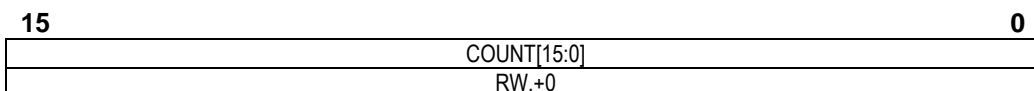

Field	Description
COUNT[15:0]	The current value of the clock counter. This starts at a value of PERIOD, and counts down to 0.

6.3.6 ADVANCED INTERRUPT N

Two Advanced Interrupt block are provided that can generate an interrupt on a match, event, or strobe. The match and event interrupts are across all 48 digital I/O. The bits can be individually selected.

When an interrupt is generated, the data on all of the ports is latched into the Capture registers.

Bits are tested regardless of if a pin is an input or output.

A Match interrupt is generated when all un-masked bits in the Compare register match the input value of the port. This is when the following expression is true for ALL ports (x) and bits (y):

$$((\text{PORTx}[y] \text{ xor } \text{ADVINTn_PORTx_CMP}[y]) \text{ and not } \text{ADVINTn_PORTx_MASK}[y]) = '0')$$

An Event interrupt is generated when any un-masked input port bit changes. This is when the following expression is true for ANY ports (x) and bits (y). Note that the Capture register is updated at every interrupt or event:

$$((\text{PORTx}[y] \text{ xor } \text{ADVINTn_PORTx_CAPT}[y]) \text{ and not } \text{ADVINTn_PORTx_MASK}[y]) = '1')$$

ADVINTn_ID

ID register to identify an Advanced Interrupt Block.

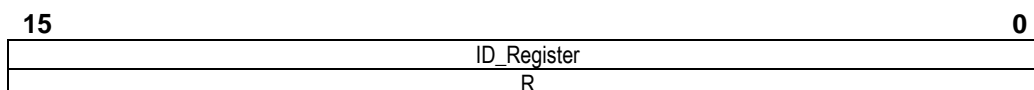

Field	Description
ID_Register[15:0]	Value of 0x0001 indicates Advanced Interrupt

ADVINTn_INT_MODE

Selects the mode for this interrupt. Event mode will generate an interrupt when any selected input pin changes. Match mode will generate an interrupt when the port(s) match a pre-set value (bits can be individually selected or masked). Strobe mode will generate an interrupt on the rising edge of the Strobe1 or Strobe2 signal.

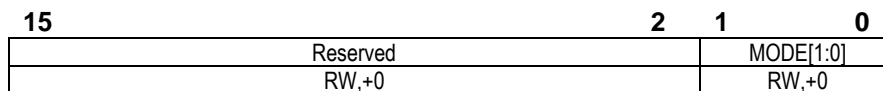

Field	Description
MODE[1:0]	Interrupt Mode. Value definitions are: 3 Event Mode 2 Match Mode 1 Strobe Mode 0 Disabled

ADVINTn_CLK

This register selects the clock source for sampling the ports when in Match or Compare mode. In Strobe mode, this register selects the actual strobe signal, and the 25 MHz clock always serves as the sampling clock.

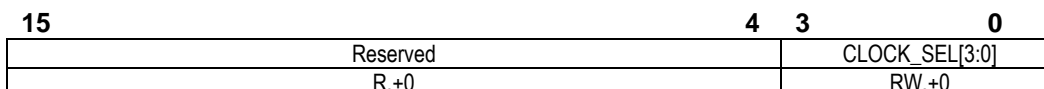

Field	Description
CLOCK_SEL[3:0]	Selects the master clock. Value definitions are: 15 Inverted Strobe2 14 Inverted Strobe1 13 Strobe2

Field	Description
	12 Strobe1
	11 Prog. Clock 3
	10 Prog. Clock 2
	9 Prog. Clock 1
	8 Prog. Clock 0
	7 82C54 TC B2
	6 82C54 TC B1
	5 82C54 TC B0
	4 82C54 TC A2
	3 82C54 TC A1
	2 82C54 TC A0
	1 Reserved
	0 25 MHz

ADVINTn PORTx MASK

This register determines if a bit is checked for the match and event interrupts.

Note: If Match mode is selected, and all bits are masked, an interrupt will be generated immediately.

15	14	13	12	11	10	9	8
Px_15	Px_14	Px_13	Px_12	Px_11	Px_10	Px_9	Px_8
RW,+0	RW,+0	RW,+0	RW,+0	RW,+0	RW,+0	RW,+0	RW,+0

7	6	5	4	3	2	1	0
Px_7	Px_6	Px_5	Px_4	Px_3	Px_2	Px_1	Px_0
RW,+0	RW,+0	RW,+0	RW,+0	RW,+0	RW,+0	RW,+0	RW,+0

Field	Description
Px_[15:0]	Bit mask. Bit definitions are: '0' = Bit is used for match/event '1' = Bit is ignored

ADVINTn PORTx CMP

The compare register is used for the Match interrupt. When all selected bits in this register match all selected bits on the input ports, an interrupt is generated.

15	14	13	12	11	10	9	8
Px_15	Px_14	Px_13	Px_12	Px_11	Px_10	Px_9	Px_8
RW,+0	RW,+0	RW,+0	RW,+0	RW,+0	RW,+0	RW,+0	RW,+0

7	6	5	4	3	2	1	0
Px_7	Px_6	Px_5	Px_4	Px_3	Px_2	Px_1	Px_0
RW,+0	RW,+0	RW,+0	RW,+0	RW,+0	RW,+0	RW,+0	RW,+0

Field	Description
Px_[15:0]	Compare Value. Bit definitions are: '0' = Interrupt when this bit is '0' (when selected) '1' = Interrupt when this bit is '1' (when selected)

ADVINTn PORTx CAPT

The Capture register latches the input ports when an interrupt is generated. All values are latched, regardless of the Mask register, or if the port is an input or output.

15	14	13	12	11	10	9	8
Px_15	Px_14	Px_13	Px_12	Px_11	Px_10	Px_9	Px_8
R,+0	R,+0	R,+0	R,+0	R,+0	R,+0	R,+0	R,+0

7	6	5	4	3	2	1	0
Px_7	Px_6	Px_5	Px_4	Px_3	Px_2	Px_1	Px_0
R,+0	R,+0	R,+0	R,+0	R,+0	R,+0	R,+0	R,+0

Field	Description
Px_[15:0]	Captured Value. Bit definitions are: '0' = Input was '0' at last interrupt. '1' = Input was '1' at last interrupt.

6.3.7 DUAL INCREMENTAL ENCODER N

Each Incremental Encoder block provides two encoder channels with 16 bit counters. These two channels can be linked into a single 32 counter.

An Incremental Encoder is used to detect the relative position of a shaft or linear actuator. A typical implementation is a slotted wheel with two optical sensors positioned such that when one sensor is positioned over a slot, the other is positioned between slots. The output of the optical sensors is shown in Figure 11, with one sensor named "A," and the other named "B." At every edge of the "A" or "B" input, the counter either increments or decrements. The direction can be interpreted from the state of the signals, i.e. which signal leads.

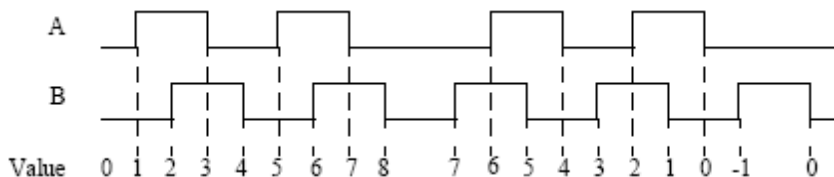

Figure 11: Incremental Encoder Signals

The encoders include a "Phase Filter" that prevents the counter from counting on certain transitions. This allows the encoders to count pulses, and other specialized applications.

Encoder inputs can be configured as single ended or pseudo-differential. In pseudo-differential mode, the "+" and "-" inputs must be the inverse of each other in order for the encoder to see a change.

Digital filtering can be selected. With digital filtering, a transition on a line is only considered valid if it remains constant for four clock cycles. The clock can be selected.

Separate interrupts are generated for positive and negative rollover. Positive rollover occurs when the counter is at its maximum value, and receives a signal to count up. Negative rollover occurs when the counter is at 0, and receives a signal to count down. Because separate interrupts are generated, the counter can be easily expanded in software.

The Incremental Encoder inputs are show in Table 11 below.

Table 11: Incremental Encoder Inputs

Pin	Encoder 0		Encoder 1	
	Channel A	Channel B	Channel A	Channel B
A+	Port0[0]	Port0[8]	Port1[0]	Port1[8]
A-	Port0[1]	Port0[9]	Port1[1]	Port1[9]
B+	Port0[2]	Port0[10]	Port1[2]	Port1[10]
B-	Port0[3]	Port0[11]	Port1[3]	Port1[11]
Index +	Port0[4]	Port0[12]	Port1[4]	Port1[12]
Index -	Port0[5]	Port0[13]	Port1[5]	Port1[13]

INCENCn_ID

ID register to identify this block.

15	ID_Register	0
	R	

Field	Description
ID_Register[15:0]	Value of 0x0002 indicates Dual Incremental Encoder

INCENCn INT

This register provides the status and enables for the encoder interrupts.

15	14	11	10	9	8
Reserved	STAT_B_NEG	STAT_B_POS	STAT_A_NEG	STAT_A_POS	
R,+0	RC,+0	RC,+0	RC,+0	RC,+0	

7	4	3	2	1	0
Reserved	ENA_B_NEG	ENA_B_POS	ENA_A_NEG	ENA_A_POS	
R,+0	RW,+0	RW,+0	RW,+0	RW,+0	

Field	Description
STAT_B_NEG	Indicates channel B has transitioned from 0x0000 to 0xFFFF. (Negative rollover) '0' = Interrupt has not occurred '1' = Interrupt has occurred. Write '1' to clear.
STAT_B_POS	Indicates channel B has transitioned from 0xFFFF to 0x0000. (Positive rollover) '0' = Interrupt has not occurred '1' = Interrupt has occurred. Write '1' to clear.
STAT_A_NEG	Indicates channel A has transitioned from 0x0000 to 0xFFFF. (Negative rollover) '0' = Interrupt has not occurred '1' = Interrupt has occurred. Write '1' to clear.
STAT_A_POS	Indicates channel A has transitioned from 0xFFFF to 0x0000. (Positive rollover) '0' = Interrupt has not occurred '1' = Interrupt has occurred. Write '1' to clear.
ENA_B_NEG	Enables interrupt when channel B transitions from 0x0000 to 0xFFFF. (Negative rollover) '0' = Interrupt is disabled '1' = Interrupt is enabled.
ENA_B_POS	Enables interrupt when channel B transitions from 0xFFFF to 0x0000. (Positive rollover) '0' = Interrupt is disabled '1' = Interrupt is enabled.
ENA_A_NEG	Enables interrupt when channel A transitions from 0x0000 to 0xFFFF. (Negative rollover) '0' = Interrupt is disabled '1' = Interrupt is enabled.
ENA_A_POS	Enables interrupt when channel A transitions from 0xFFFF to 0x0000. (Positive rollover) '0' = Interrupt is disabled '1' = Interrupt is enabled.

INCENCn_CLK

This register selects the clock source for sampling the encoder inputs.

15	Reserved	4	3	0
	R,+0	CLOCK_SEL[3:0]		RW,+0

Field	Description
CLOCK_SEL[3:0]	Selects the master clock. Value definitions are: 15 Inverted Strobe2 14 Inverted Strobe1 13 Strobe2 12 Strobe1 11 Prog. Clock 3 10 Prog. Clock 2 9 Prog. Clock 1 8 Prog. Clock 0 7 82C54 TC B2 6 82C54 TC B1 5 82C54 TC B0 4 82C54 TC A2 3 82C54 TC A1 2 82C54 TC A0 1 Reserved 0 25 MHz

INCENCn_MODE

This register selects the mode of operation for the Incremental Encoder.

15	PHASE_FLT[7:0]	8
	RW,+0	

7	6	5	4	3	2	1	0
Reserved	DIFF	FILTER	JOIN	IDX_EN	HOLD	ENA	
R,+0	RW,+0	RW,+0	RW,+0	RW,+0	RW,+0	RW,+0	RW,+0

Field	Description																																				
PHASE_FLT[7:0]	Phase Filter: Selects if a particular state transition will cause the encoder counter to change. For each bit: '0' = Transition will change counter '1' = Transition will not change counter. The bit assignments for the transitions are: <table border="1" style="margin-left: 20px;"> <thead> <tr> <th>Bit</th> <th>Previous State [B:A]</th> <th>Current State [B:A]</th> <th>Direction</th> </tr> </thead> <tbody> <tr><td>7</td><td>00</td><td>10</td><td>Down</td></tr> <tr><td>6</td><td>10</td><td>11</td><td>Down</td></tr> <tr><td>5</td><td>11</td><td>01</td><td>Down</td></tr> <tr><td>4</td><td>01</td><td>00</td><td>Down</td></tr> <tr><td>3</td><td>10</td><td>00</td><td>Up</td></tr> <tr><td>2</td><td>11</td><td>10</td><td>Up</td></tr> <tr><td>1</td><td>01</td><td>11</td><td>Up</td></tr> <tr><td>0</td><td>00</td><td>01</td><td>Up</td></tr> </tbody> </table>	Bit	Previous State [B:A]	Current State [B:A]	Direction	7	00	10	Down	6	10	11	Down	5	11	01	Down	4	01	00	Down	3	10	00	Up	2	11	10	Up	1	01	11	Up	0	00	01	Up
Bit	Previous State [B:A]	Current State [B:A]	Direction																																		
7	00	10	Down																																		
6	10	11	Down																																		
5	11	01	Down																																		
4	01	00	Down																																		
3	10	00	Up																																		
2	11	10	Up																																		
1	01	11	Up																																		
0	00	01	Up																																		
DIFF	Selects single-ended or differential mode '0' = Single Ended. Only "+" inputs are used '1' = Pseudo-Differential																																				

Field	Description
FILTER	Enable the input filter '0' = Filter is disabled '1' = Filter is enabled
JOIN	Used to join the two channels into a single 32 bit counter. When the channels are joined, only the Channel A inputs are used. '0' = Channels are independent '1' = Channels are joined.
IDX_EN	Index Enable: When enabled, a high input on the Index input clears the counter '0' = Index Inputs Disabled '1' = Index Input Enabled
HOLD	Register Hold: When enabled, the encoder continues counting in the background, but the VALUE registers remain constant. '0' = VALUE registers are not held '1' = VALUE registers are held
ENA	Enable for this incremental encoder '0' = Encoder is disabled '1' = Encoder is enabled

INCENCn_VALUEy

Returns the current value of this incremental encoder channel. When INCENCx_MODE[JOIN] = 1, INCENCx_VALUEB contains the most significant word, and INCENCx_VALUEA contains the least significant word. A 16 bit read should be used to read this register when not joined (INCENCx_MODE[JOIN] = 0), and a 32 bit read should be used when joined (INCENCx_MODE[JOIN] = 1). Otherwise, the value can change between read operations. Another option is to set INCENCx_MODE[HOLD] = 1, read the contents of the register, and then set INCENCx_MODE[HOLD] = 0.

This register can only be written to when INCENCx_MODE[ENA] = 0. This allows the counter to be pre-loaded with a known position value.

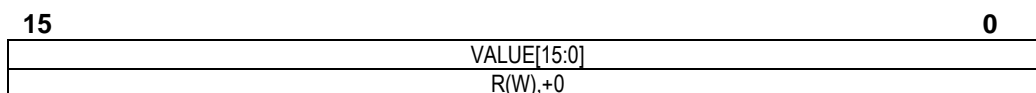

Field	Description
VALUE[15:0]	The current value of this incremental encoder channel.

6.3.8 QUAD PULSE WIDTH MODULATOR N

The Pulse Width Modulator block provides four PWM outputs. Each output consists of a non-inverted and inverted signal. These signals are available on select pins as peripheral outputs. The period and width of the output is set with 16 bit resolution.

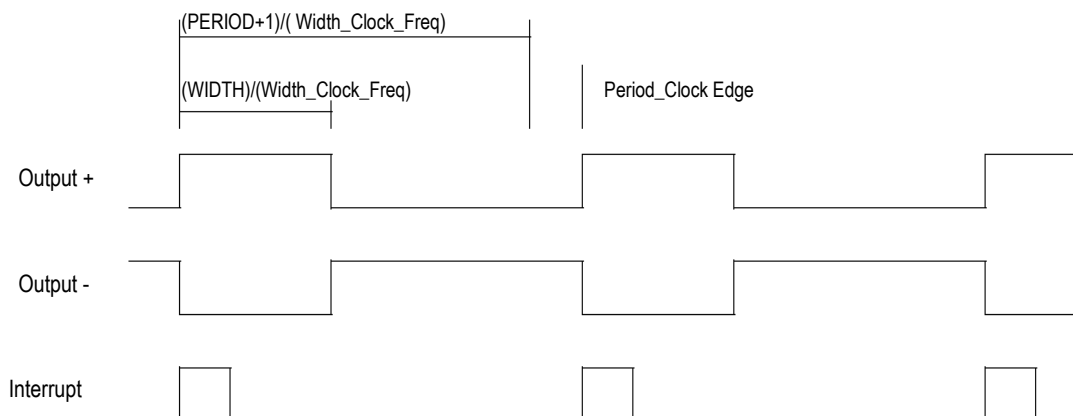

Figure 12: PWM Output

All of the PWM outputs have the same period. The pulse width of each of the four outputs is individually adjustable.

The PWM can use separate clocks for width and period. The width clock is used to decrement the counter. When the counter reaches zero, it will wait for the next period clock to re-load the counter with the period value.

In a typical PWM implementation, the same clock is used for width and period. By using separate clocks, a high resolution can be achieved with low duty cycle outputs. For example, if a 1 MHz clock is used for the period clock and the PERIOD register is set to its maximum value, and a 10 MHz clock is used for the width clock, the duty cycle range is 0% to 10%, with a full 16 bit resolution across that range.

Note that if the PERIOD register is set to its maximum value, a duty cycle of 100% cannot be achieved.

An interrupt is generated at the beginning of every period.

The width register is checked at the beginning of every period. If the width register is modified in the middle of a period, the output will not be affected until the next period.

PWMn_ID

ID register to identify this block.

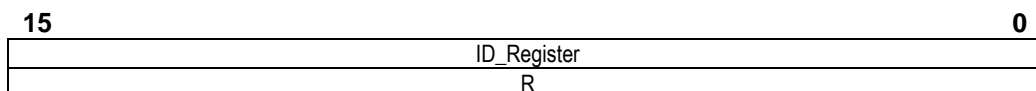

Field	Description
ID_Register[15:0]	Value of 0x0003 indicates Pulse Width Modulator

PWMn_MODE

This register is used to enable and disable the Pulse Width Modulator. When disabled, all non-inverted outputs are low, and all inverted outputs are high, and interrupts are not generated.

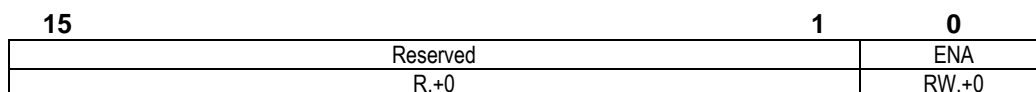

Field	Description
ENA	Enables or disabled the PWM. '0' = Disabled '1' = Enabled

PWMn_CLK

This register selects the clock sources for the period and width of the PWM output.

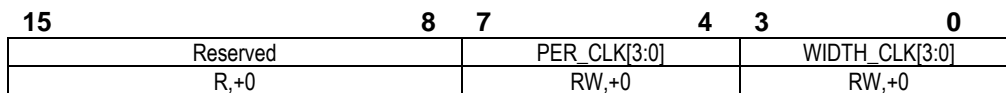

Field	Description
PER_CLK [3:0]	Selects the master clock for the period counter. Value definitions are: 15 Inverted Strobe2 14 Inverted Strobe1 13 Strobe2 12 Strobe1 11 Prog. Clock 3 10 Prog. Clock 2 9 Prog. Clock 1

Field	Description
	8 Prog. Clock 0
	7 82C54 TC B2
	6 82C54 TC B1
	5 82C54 TC B0
	4 82C54 TC A2
	3 82C54 TC A1
	2 82C54 TC A0
	1 Reserved
	0 25 MHz
WIDTH_CLK[3:0]	Selects the master clock for the width counter. See above for value definitions.

PWMn PERIOD

Sets the maximum width of the PWM outputs. If the period clock and width clock are the same (PWMn_CLK[PER_CLK] = PWMn_CLK[WIDTH_CLK]), this will also set the PWM period. See Figure 12 on page 57 for more details.

15	PERIOD[15:0]	0
RW,+0		

Field	Description
PERIOD[15:0]	The period of the output is the next period clock after: $\frac{(PERIOD + 1)}{Width_Clock_Frequency}$

PWMn WIDTHx

Sets the width of output x of the pulse width modulator. The width is based on the clock selected in PWMn_CLK[WIDTH_CLK]. The width is defined as the time that the non-inverted output is high, and the inverted output is low.

The width register is checked at the beginning of every period. If the width register is modified in the middle of a period, the output will not be affected until the next period.

Note that with PWMn_PERIOD set to the maximum value, and the period clock and width clock set to the same source, a 100% duty cycle is not possible.

15	WIDTH[15:0]	0
RW,+0		

Field	Description
WIDTH[15:0]	The width of the output: $\frac{WIDTH}{Width_Clock_Frequency}$

6.3.9 82C54 TIMER COUNTER N

The following section is taken from the MSM82C54 Datasheet from Oki Semiconductors. For information on programming the 82C54 timer counters, please consult the datasheet.

DESCRIPTION OF OPERATION

MSM82C54-2 functions are selected by control words from the CPU. In the required program sequence, the control word setting is followed by the count value setting and execution of the desired timer operation.

Control Word and Count Value Program

Each counter operating mode is set by control word programming. The control word format is outlined below.

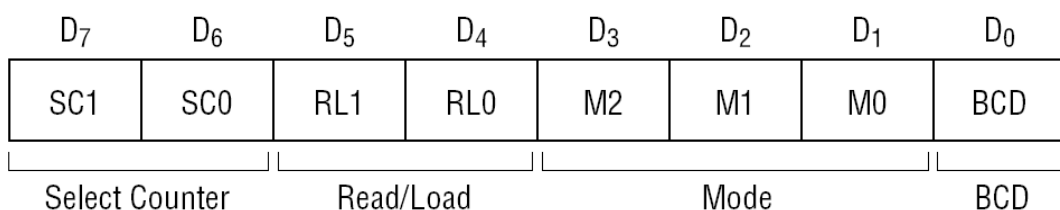

$$(\overline{CS}=0, A_0, A_1=1, 1, \overline{RD}=1, \overline{WR}=0)$$

Table 12: Select Counter SC[1:0]: Selection of set counter

SC[1:0]	Set Contents
00	Counter #0 Selection
01	Counter #1 Selection
10	Counter #2 Selection
11	Read Back Command

Table 13: Read/Load RL[1:0]: Count Value Reading/Loading format setting

RL[1:0]	Set Contents
00	Counter Latch Operation
01	Reading/Loading of Least Significant Byte (LSB)
10	Reading/Loading of Most Significant Byte (MSB)
11	Reading/Loading of LSB followed by MSB

Table 14: Mode M[2:0]: Operation waveform mode setting

M[1:0]	Set Contents	Min Count Value	Max Count Value
000	Mode 0 (Interrupt on Terminal Count)	1	0
001	Mode 1 (Programmable One-Shot)	1	0
x10	Mode 2 (Rate Generator)	2	0
x11	Mode 3 (Square Wave Generator)	2	0
100	Mode 4 (Software Triggered Strobe)	1	0
101	Mode 5 (Hardware Triggered Strobe)	1	0

x denotes "not specified"

Count value of 0 executed 0x10000 count

Table 15: BCD: Operation count mode setting

BCD	Set Contents
0	Binary Count (16-bit Binary)
1	BCD Count (4-decade Binary Coded Decimal)

After setting Read/Load, Mode and BCD in each counter as outlined above, next set the desired count value. (In some Modes, the count value is set first. In next clock, loading is performed, and then counting starts.) This count value setting must conform to the Read/Load format set in advance. Note that the internal counters are reset to 0000H during control word setting. The counter value (0000H) can't be read.

The program sequence of the MSM82C54-2 is flexible. Free sequence programming is possible as long as the two following rules are observed:

- (i) Write the control word before writing the initial count value in each counter.
- (ii) Write the initial count value according to the count value read/write format specified by the control word.

Note: Unlike the MSM82C53-2, the MSM82C54-2 allows count value setting for another counter between LSB and MSB settings.

Mode definition

Mode 0

- Application: Event counter
- Output operation: The output is set to "L" level by the control word setting, and kept at "L" level until the counter value becomes 0.
- Gate function: "H" level validates the count operation, and "L" level invalidates it. The gate does not affect the output.
- Count value load timing: after the control word and initial count value are written, the count value is loaded to the CE at the falling edge of the next clock pulse. The first clock pulse does not cause the count value to be decremented. In other words, if the initial count value is N, the output is not set to "H" level until the input of (N+1) the clock pulse after the initial count value writing.
- Count value writing during counting: The count value is loaded in the CE at the falling edge of the next clock, and counting with the new count value continues. The operation for 2-byte count is as follows:
- The counting operation is suspended when the first byte is written. The output is immediately set to "L" level. (No clock pulse is required.)
- After the second byte is written, the new count value is loaded to the CE at the falling edge of the next clock.
- For the output to go to "H" level again, N+1 clock pulse are necessary after new count value N is written.
- Count value writing when the gate signal is "L" level: The count value is also loaded to the CE at the falling edge of the next clock pulse in this case. When the gate signal is set to "H" level, the output is set to "H" level after the lapse of N clock pulses. Since the count value is already loaded in the CE, no clock pulse for loading in the CE is necessary.

Mode 1

- Application: Digital one-shot
- Output operation: The output is set to "H" level by the control word setting. It is set to "L" level at the falling edge of the clock succeeding the gate trigger, and kept at "L" level until the counter value becomes 0. Once the output is set to "H" level, it is kept at "H" level until the clock pulse succeeding the next trigger pulse.
- Count value load timing: After the control word and initial count value are written, the count value is loaded to the CE at the falling edge of the clock pulse succeeding the gate trigger and set the output to "L" level. The one-shot pulse starts in this way. If the initial count value is N, the one-shot pulse interval equals N clock pulses. The one-shot pulse is not repetitive.
- Gate function: The gate signal setting to "L" level after the gate trigger does not affect the output. When it is set to "H" level again from "L" level, gate retriggering occurs, the CR count value is loaded again, and counting continues.
- Count value writing during counting: It does not affect the one-shot pulse being counted until retriggering occurs.

Mode 2

- Application: Rate generator, real-time interrupt clock.
- Output operation: The output is set to "H" level by control word setting. When the initial count value is decremented to 1, the output is set to "L" level during one clock pulse, and is then set to "H" level again. The initial count value is reloaded, and the above sequence repeats. In mode 2, the same sequence is repeated at intervals of N clock pulses if the initial count value is N for example.
- Gate function: "H" level validates counting and "L" level invalidates it. If the gate signal is set to "L" level when the output pulse is "L" level, the output is immediately set to "H" level. At the falling edge of the clock pulse succeeding the trigger, the count value is reloaded and counting starts. The gate input can be used for counter synchronization in this way.
- Count value load timing: After the control word and initial count value is written, the count value is loaded to the CE at the falling edge of the next clock pulse. The output is set to "L" level upon lapse of N clock pulses after writing the initial count value N. Counter synchronization by software is possible in this way.
- Count value writing during counting: Count value writing does not affect the current counting operation sequence. If new count value writing completes and the gate trigger arrives before the end of current counting operation, the count value is loaded to the CE at the falling edge of next clock pulse and counting continues from the new count value. If no gate trigger arrives, the new count value is loaded to the CE at the end of the current counting operation cycle. In mode 2, count value of 1 is prohibited.

Mode 3

- Application: Baud rate generator, square wave generator
- Output operation: Same as mode 2 except that the output duty is different. The output is set to "H" level by control word setting. When the count becomes half the initial count value, the output is set to "L" level and kept at "L" level during the remainder of the count. Mode 3 repeats the above sequence periodically. If the initial count value is N, the output becomes a square wave with a period of N.
- Gate operation: "H" level validates counting and "L" level invalidates it. If the gate signal is set to "L" level when the output is "L" level, the output is immediately set to "H" level. The initial count value is reloaded at the falling edge of the clock pulse succeeding the next gate trigger. The gate can be used for counter synchronization in this way.
- Count value load timing: After the control word and initial count value are written, the count value is loaded to the CE at the falling edge of the next clock pulse; Counter synchronization by software is possible in this way.
- Count value writing during counting: The count value writing does not affect the current counting operation. When the gate trigger input arrives before the end of a half cycle of the square wave after writing the new count value, the new count value is loaded in the CE at the falling edge of the next clock pulse, and counting continues using the new count value. If there is no gate trigger, the new count value is loaded at the end of the half cycle and counting continues.
- Even number counting operation: The output is initially set to "H" level. The initial count value is loaded to the CE at the falling edge of the next clock pulse, and is decremented by 2 by consecutive clock pulses. When the counter value becomes 2, the output is set to "L" level, the initial value is reloaded and then the above operation is repeated.
- Odd number counting operation: The output is initially set to "H" level. At the falling edge of the next clock pulse, the initial count value minus one is loaded in the CE, and then the value is decremented by 2 by consecutive clock pulses. When the counter value becomes 0, the output is set to "L" level, and then the initial count value minus 1 is reloaded to the CE. The value is then decremented by 2 by consecutive clock pulses. When the counter value becomes 2, the output is again set to "H" level and the initial count value minus 1 is again reloaded. The above operations are repeated. In other words, the output is set to "H" level during $(N+1)/2$ counting and to "L" level during $(N-1)/2$ counting in the case of odd number counting.

Mode 4

- Application: Software trigger strobe
- Output operation: The output is initially set to "H" level. When the counter value becomes 0, the output goes to "L" level during one clock pulse, and then restores "H" level again. The count sequence starts when the initial count value is written.
- Gate function: "H" level validates counting and "L" level invalidates counting. The gate signal does not affect the output.
- Count value load timing: After the control word and initial count value are written, the count value is loaded to the CE at the falling edge of the next clock pulse. The clock pulse does not decrement the initial count value. If the initial count value is N, the strobe is not output unless N+1 clock pulses are input after the initial count value is written,
- Count value writing during counting: The new count value is written to the CE at the falling edge of the next clock pulse, and counting continues using the new count value. The operation for 2-byte count is as follows:
 - First byte writing does not affect the counting operation.
 - After the second byte is written, the new count value is loaded to the CE at the falling edge of the next clock pulse.
- This means that the counting operation is retriggered by software. The output strobe is set to "L" level upon input of N+1 clock pulses after the new count value N is written.

Mode 5

- Application: Hardware trigger strobe
- Output operation: The output is initially set to "H" level. When the counter value becomes 0 after triggering by the rising edge of the gate pulse, the output goes to "L" level during one clock pulse, and then restores "H" level.
- Count value load timing: Even after the control word and initial count value are written, loading to the CE does not occur until the input of the clock pulse succeeding the trigger. For the clock pulse for CE loading, the count value is not decremented. If the initial count value is N, therefore, the output is not set to "L" level until N+1 clock pulses are input after triggering.
- Gate function: The initial count value is loaded to the CE at the falling edge of the clock pulse succeeding gate triggering. The count sequence can be retriggered. The gate pulse does not affect the output.

- Count value writing during counting: The count value writing does not affect the current counting sequence. If the gate trigger is generated after the new count value is written and before the current counting ends, the new count value is loaded to the CE at the falling edge of the next clock pulse, and counting continues using the new count value. The various roles of the gate input signals in the above modes are summarized in the following table.

Mode \ Gate	"L" Level Falling Edge	Rising Edge	"H" Level
0	Counting not possible		Counting possible
1		(1) Start of counting (2) Retriggering	
2	(1) Counting not possible (2) Counter output forced to "H" level	Start of counting	Counting possible
3	(1) Counting not possible (2) Counter output forced to "H" level	Start of counting	Counting possible
4	Counting not possible		Counting possible
5		(1) Start of counting (2) Retriggering	

Mode 0

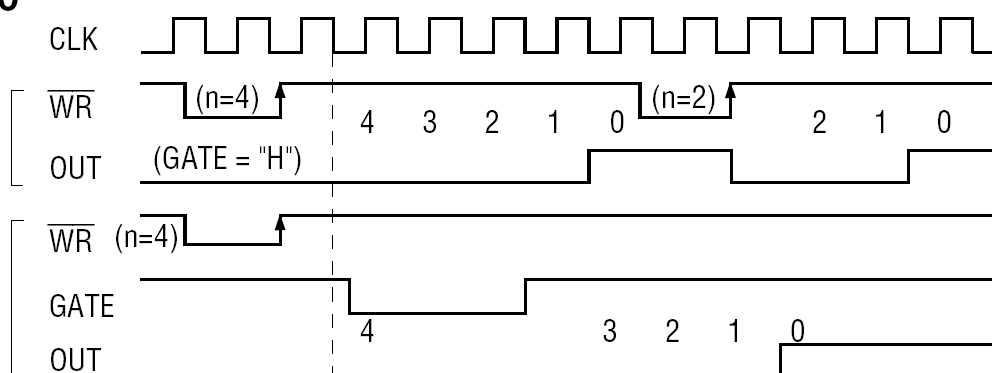

Mode 1

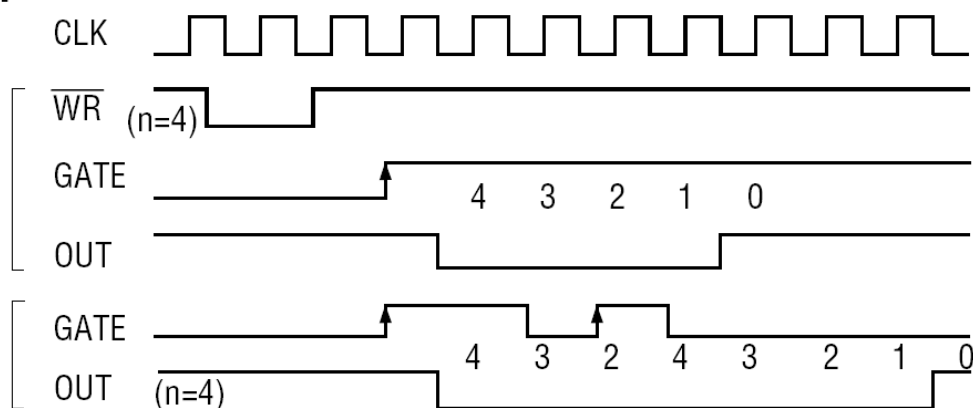

Mode 2

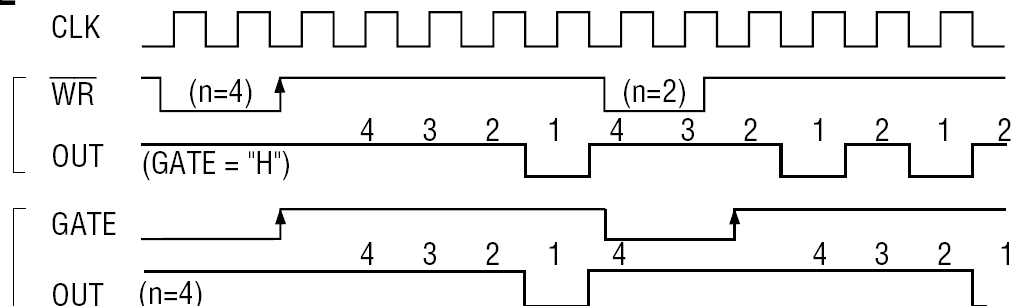

Mode 3

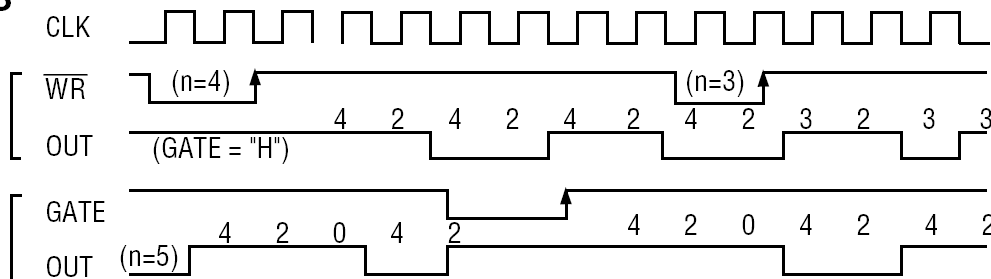

Mode 4

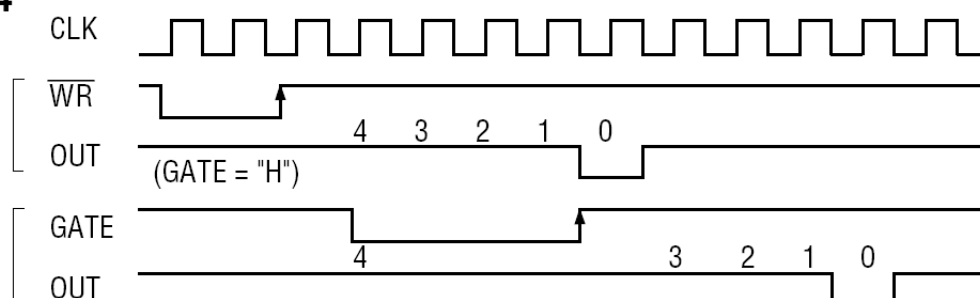

Mode 5

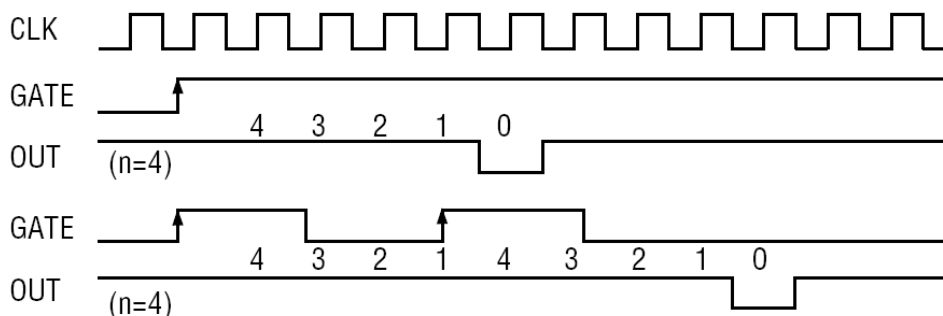

Note : "n" is the value set in the counter.
 Figures in these diagrams refer to counter values.

Reading Counter Values

All MSM82C54-2 counting is down-counting, the counting being in steps of 2 in mode 3. Counter values can be read during counting by: (1) direct reading, (2) counter latching ("read on the fly"), and (3) read back command.

Direct reading

Counter values can be read by direct reading operations. Since the counter value read according to the timing of the RD and CLK signals is not guaranteed, it is necessary to stop the counting by a gate input signal, or to interrupt the clock input temporarily by an external circuit to ensure that the counter value is correctly read.

Counter latching

In this method, the counter value is latched by writing counter latch command, thereby enabling a stable value to be read without effecting the counting in any way at all. The output latch (OL) of the selected counter latches the count value when a counter latch command is written. The count value is held until it is read by the CPU or the control word is set again.

If a counter latch command is written again before reading while a certain counter is latched, the second counter latch command is ignored and the value latched by the first counter latch command is maintained.

The MSM82C54-2 features independent reading and writing from and to the same counter. When a counter is programmed for the 2-byte counter value, the following sequence is possible:

1. Count value (LSB) reading
2. New count value (LSB) writing
3. Count value (MSB) reading
4. New count value (MSB) writing

An example of a counter latching program is given below.

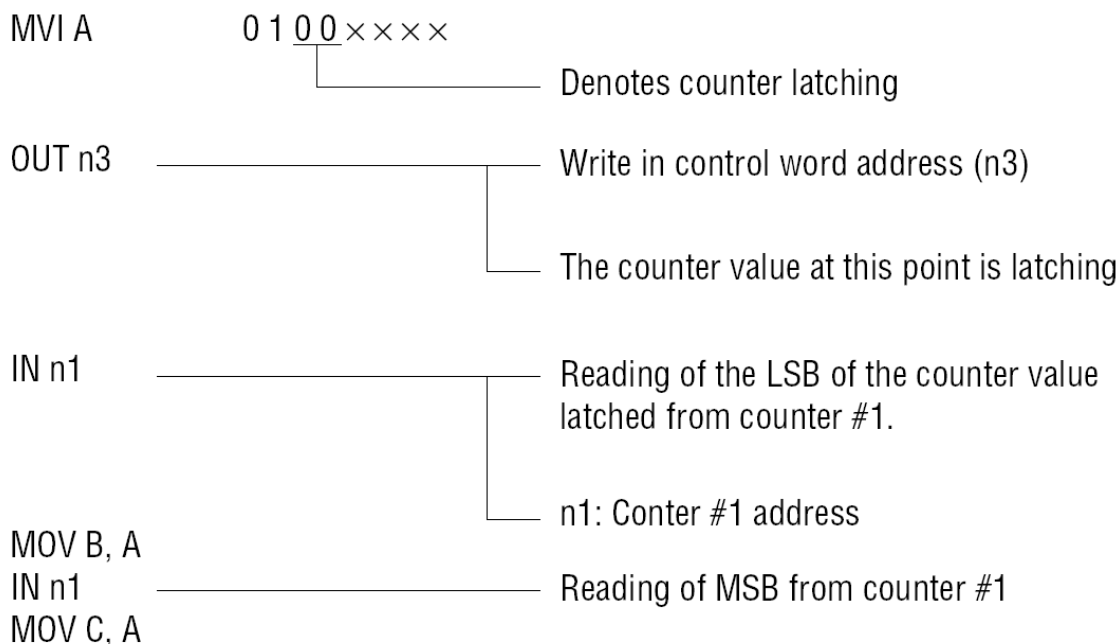

Figure 13: Counter latching executed for counter #1 (Read/Load 2-byte setting)

Read Back Command Operation

Use of the read back command enables the user to check the count value, program mode, output pin state and null count flag of the selected counter. The command is written in the control word register, and the format is as shown below. For this command, the counter selection occurs according to bits D3, D2 and D1.

D ₇	D ₆	D ₅	D ₄	D ₃	D ₂	D ₁	D ₀
1	1	$\overline{\text{COUNT}}$	$\overline{\text{STATUS}}$	CNT2	CNT1	CNT0	0

(CS=0, A₀, A₁=1, RD=1, WR=0)

D₅: 0 = Selected counter latch operation

D₄: 0 = Selected counter status latch operation

D₃: 1 = Counter #2 selection

D₂: 1 = Counter #1 selection

D₁: 1 = Counter #0 selection

D₀: 0 Fixed

It is possible to latch multiple counters by using the read back command. Latching of a read counter is automatically canceled but other counters are kept latched. If multiple read back commands are written for the same counter, commands other than the first one are ignored. It is also possible to latch the status information of each counter by using the read back command. The status of a certain counter is read when the counter is read. The counter status format is as follows:

Bits D₅ to D₀ indicate the mode programmed by the most recently written control word.

Bit D₇ indicates the status of the output pin. Use of this bit makes it possible to monitor the counter output, so the corresponding hardware may be omitted.

D ₇	D ₆	D ₅	D ₄	D ₃	D ₂	D ₁	D ₀
OUTPUT	NULL COUNT	RL1	RL0	M2	M1	M0	BCD

D₇: 1 = Output pin status is 1.

0 = Output pin status is 0.

D₆: 1 = Null count

0 = Count value reading is effective

D₅ - D₀: Programmed mode of counter

(See the control word format.)

Null count indicates the count value finally written in the counter register (CR) has been loaded in the counter element (CE). The time when the count value was loaded in the CE depends on the mode of each counter, and it cannot be known by reading the counter value because the count value does not tell the new count value if the counter is latched. The null count operation is shown below.

Operation	Result
A. Control word register writing	Null count = 1
B. Count register (CR) writing	Null count = 1

C. New count loading to CE (CR->CE) Null count = 0

Note: The null count operation for each counter is independent. When the 2-byte count is programmed, the null count is set to 1 when the count value of the second byte is written.

If status latching is carried out multiple times before status reading, other than the first status latch is ignored.

Simultaneous latching of the count and status of the selected counter is also possible. For this purpose, set bits D4 and D3, COUNT and STATUS bits, to 00. This is functionally the same as writing two separate read back commands at the same time. If counter/status latching is carried out multiple times before each reading, other than the first one is ignored here again. The example is shown below.

Command								Contents	Counter 0		Counter 1		Counter 2	
D ₇	D ₆	D ₅	D ₄	D ₃	D ₂	D ₁	D ₀		Count	Status	Count	Status	Count	Status
1	1	0	0	0	0	1	0	Read back status and count (counter 0)	L	L	—	—	—	—
1	1	1	0	0	1	0	0	Read back status (counter 1)	L	L	—	L	—	—
1	1	1	0	1	1	0	0	Read back status (counter 1 and 2)	L	L	—	L (NOTE)	—	L
1	1	0	1	1	0	0	0	Read back status (counter 2)	L	L	—	L	L	L
1	1	0	0	0	1	0	0	Read back status and count (counter 1)	L	L	L	L (NOTE)	L	L
1	1	1	0	0	0	1	0	Read back status (counter 0)	L	L (NOTE)	L	L	L	L

Note: The latch command at this time point is ignored, and the first latch command is valid.

If both the count and status are latched, the status latched in the first counter read operation is read. The order of count latching and status latching is irrelevant. The count(s) of the next one or two reading operations is or are read.

6.4 PLX Registers

The PLX9056 PCI Accelerator on the DMx820HR contains several registers to control interrupts and the two DMA engines. These engines allow data to be transferred on-demand with no load on the processor. The following sections describe the registers used for programming the DMA engines. This information is taken from PLX PCI9065BA Datasheet. For more information, please consult the datasheet.

6.4.1 MEMORY MAP OVERVIEW

Table 16 shows the memory map of the DMx820HR DMA registers. These are found at the memory offset from BAR0, or the I/O offset from BAR1.

Table 16: PLX DMx820HR Memory Map

Offset (Hex)	Register Name	Register Description
DMA Channel 0		
0x80	DMAMODE0	DMA Channel 0 Mode
0x84 0x88	DMAPADR0	DMA Channel 0 PCI Address
0x88 0x8C	DMALADR0	DMA Channel 0 Local Address
0x8C 0x84	DMASIZ0	DMA Channel 0 Transfer Size (Bytes)
0x90	DMADPR0	DMA Channel 0 Descriptor Pointer
DMA Channel 1		
0x94	DMAMODE1	DMA Channel 1 Mode
0x98 0x9C	DMAPADR1	DMA Channel 1 PCI Address
0x9C 0xA0	DMALADR1	DMA Channel 1 Local Address
0xA0 0x98	DMASIZ1	DMA Channel 1 Transfer Size (Bytes)
0xA4	DMADPR1	DMA Channel 1 Descriptor Pointer
Command and Status		
0xA8	DMACSR0	DMA Channel 0 Command/Status
0xA9	DMACSR1	DMA Channel 1 Command/Status
0xAC	DMAARB	DMA Arbitration
0xB0	DMATHR	DMA Threshold
0xB4	DMADA0	DMA Channel 0 PCI Dual Address Cycle Upper Address
0xB8	DMADA1	DMA Channel 1 PCI Dual Address Cycle Upper Address
Interrupt		
0x68	INTCSR	Interrupt Control/Status

Where two addresses are given, the left column is the address when DMAMODEn[20] = 0, and the right column is the address when DMAMODEn[20] = 1.

6.4.2 DMA REGISTER DESCRIPTION

DMAMODEn

DMA Mode

Bit	Description	Read	Write	Value after Reset	Value to Use
1:0	Local Bus Data Width. Writing of the following values indicates the associated bus data width: 00b = 8 bit 01b = 16 bit 10b or 11b = 32 bit	Yes	Yes	11b	11b

5:2	Internal Wait State Counter (Address-to-Data; Data-to-Data; 0 to 15 Wait States).	Yes	Yes	0h	0h
6	TA#/READY# Input Enable. Writing 1 enables READY# input. Writing 0 disables READY# input.	Yes	Yes	1	1
7	Continuous Burst Enable. When bursting is enabled (DMAMODE0[8]=1), writing 1 enables Continuous Burst mode and writing 0 enables Burst-4 mode. Writing 1 additionally enables BTERM# input, which when asserted overrides the READY# input state (if READY# is enabled, DMAMODE0[6]=1). Notes: This bit is referred to as the "BTERM# Input Enable" bit. Refer to Section 4.2.5 of the PCI9056 datasheet for further details.	Yes	Yes	0	1
8	Local Burst Enable. Writing 1 enables Local bursting. Writing 0 disables Local bursting.	Yes	Yes	0	1
9	Scatter/Gather Mode. Writing 1 indicates DMA Scatter/Gather mode is enabled. For Scatter/Gather mode, the DMA source and destination addresses and byte count are loaded from memory in PCI or Local Address spaces. Writing 0 indicates DMA Block mode is enabled.	Yes	Yes	0	x
10	Done Interrupt Enable. Writing 1 enables an interrupt when done. Writing 0 disables an interrupt when done. If DMA Clear Count mode is enabled (DMAMODE0[16]=1), the interrupt does not occur until the byte count is cleared	Yes	Yes	0	x
11	Local Addressing Mode. Writing 1 holds the Local Address Bus constant. Writing 0 indicates the Local Address is incremented.	Yes	Yes	0	1
12	Demand Mode. Writing 1 causes the DMA Controller to operate in Demand mode. In Demand mode, the DMA Controller transfers data when its DREQ0# input is asserted. Asserts DACK0# to indicate the current Local Bus transfer is in response to DREQ0# input. The DMA Controller transfers Lwords (32 bits) of data. This may result in multiple transfers for an 8- or 16-bit bus.	Yes	Yes	0	1
13	Memory Write and Invalidate Mode for DMA Transfers. When set to 1, the PCI 9056 performs Memory Write and Invalidate cycles to the PCI Bus. The PCI 9056 supports Memory Write and Invalidate sizes of 8 or 16 Lwords. The size is specified in the System Cache Line Size bits (PCICLSR[7:0]). If a size other than 8 or 16 is specified, the PCI 9056 performs Write transfers, rather than Memory Write and Invalidate transfers. Transfers must start and end at cache line boundaries. PCICR[4] must be set to 1.	Yes	Yes	0	x
14	EOT# Enable. Writing 1 enables the EOT# input pin. Writing 0 disables the EOT# input pin. If DMAMODE0[14] and DMAMODE1[14]=00b, the EOT# pin becomes the DMPAF pin.	Yes	Yes	0	0
15	Fast/Slow Terminate Mode Select. Writing 0 sets the PCI 9056 into Slow Terminate mode. As a result, BLAST# is asserted on the last Data transfer to terminate the DMA transfer. Writing 1 sets the PCI 9056 into Fast Terminate mode, and indicates the PCI 9056 DMA transfer terminates immediately when EOT# (if enabled) is asserted, or during DMA Demand mode when DREQ0# is de-asserted.	Yes	Yes	0	0
16	Clear Count Mode. Writing 1 clears the byte count in each Scatter/Gather descriptor when the corresponding DMA transfer is complete.	Yes	Yes	0	x

17	Interrupt Select. Writing 1 routes the interrupt to the PCI interrupt (INTA#). Writing 0 routes the interrupt to the Local interrupt output (LINTo#).	Yes	Yes	0	1
18	DAC Chain Load. When set to 1, enables the descriptor to load the PCI Dual Address Cycles value. Otherwise, the descriptor loads the DMADAC0 register contents.	Yes	Yes	0	x
19	EOT# End Link. Used only for DMA Scatter/Gather transfers. Value of 1 indicates that when EOT# is asserted, the DMA transfer ends the current Scatter/Gather link and continues with the remaining Scatter/Gather transfers. Value of 0 indicates that when EOT# is asserted, the DMA transfer ends the current Scatter/Gather transfer and does not continue with the remaining Scatter/Gather transfers.	Yes	Yes	0	0
20	Ring Management Valid Mode Enable. Value of 0 indicates the Ring Management Valid bit (DMASIZ0[31]) is ignored. Value of 1 indicates the DMA descriptors are processed only when the Ring Management Valid bit is set (DMASIZ0[31]=1). If the Valid bit is set, the transfer count is 0, and the descriptor is not the last descriptor in the chain. The DMA Controller then moves to the next descriptor in the chain. Note: Descriptor Memory fields are re-ordered when this bit is set.	Yes	Yes	0	x
21	Ring Management Valid Stop Control. Value of 0 indicates the DMA Scatter/Gather controller continuously polls a descriptor with the Valid bit set to 0 (invalid descriptor) if Ring Management Valid Mode is enabled (DMAMODE0[20]=1). Value of 1 indicates the Scatter/Gather controller stops polling when the Ring Management Valid bit with a value of 0 is detected (DMASIZ0[31]=0). In this case, the CPU must restart the DMA Controller by setting the Start bit (DMACSR0[1]=1). A pause clearing the Start bit (DMACSR0[1]=0) sets the DMA Done bit (DMACSR0[4]=1).	Yes	Yes	0	x
31:22	Reserved	Yes	No	0	0

DMAPADR_n

DMA PCI Address

Bit	Description	Read	Write	Value after Reset	Value to Use
31:0	PCI Address. Indicates from where in PCI Memory space DMA transfers (reads or writes) start. Value is a physical address.	Yes	Yes	0h	x

DMALAPADR_n

DMA Local Address

Bit	Description	Read	Write	Value after Reset	Value to Use
31:0	DMA Channel Local Address. Indicates from where in Local Memory space DMA transfers (reads or writes) start.	Yes	Yes	0h	x

DMASIZn

DMA Transfer Size

Bit	Description	Read	Write	Value after Reset	Value to Use
22:0	Transfer Size (Bytes). Indicates the number of bytes to transfer during a DMA operation.	Yes	Yes	0h	x
30:23	Reserved	Yes	No	0h	0h
31	Ring Management Valid. When Ring Management Valid Mode is enabled (DMAMODE0[20]=1), indicates the validity of this DMA descriptor.	Yes	Yes	0	x

DMAPRn

DMA Channel n Descriptor Pointer

Bit	Description	Read	Write	Value after Reset	Value to Use
0	Descriptor Location. Writing 1 indicates PCI Address space. Writing 0 indicates Local Address space.	Yes	Yes	0h	1
1	End of Chain. Writing 1 indicates end of chain. Writing 0 indicates not end of chain descriptor. (Same as DMA Block mode.)	Yes	Yes	0h	x
2	Interrupt after Terminal Count. Writing 1 causes an interrupt to be asserted after the terminal count for this descriptor is reached. Writing 0 disables interrupts from being asserted.	Yes	Yes	0h	x
3	Direction of Transfer. Writing 1 indicates transfers from the Local Bus to the PCI Bus. Writing 0 indicates transfers from the PCI Bus to the Local Bus.	Yes	Yes	0h	x
31:4	Next Descriptor Address. X0h-aligned (DMADPR0[3:0]=0h).	Yes	Yes	0h	x

DMACSRn

DMA Channel n Command/Status

Bit	Description	Read	Write	Value after Reset	Value to Use
0	Enable. Writing 1 enables the channel to transfer data. Writing 0 disables the channel from starting a DMA transfer, and if in the process of transferring data, suspends the transfer (pause).	Yes	Yes	0h	1
1	Start. Writing 1 causes the channel to start transferring data if the channel is enabled.	Yes	Yes/ Set	0h	x

2	Abort. Writing 1 causes the channel to abort the current transfer. The DMA Channel 0 Enable bit must be cleared (DMACSR0[0]=0). Sets the DMA Channel 0 Done bit (DMACSR0[4]=1) when the abort is complete.	Yes	Yes/ Set	0h	x
3	Clear Interrupt. Writing 1 clears DMA Channel 0 interrupts.	Yes	Yes/ Clr	0h	x
4	Done. Reading 1 indicates the transfer is complete. The transfer may be complete either because the DMA transfer finished successfully, or that the DMA transfer was aborted when software set the Abort bit (DMACSR0[2]=1). Reading 0 indicates the Channel transfer is not complete.	Yes	No	0h	x
7:5	Reserved.	Yes	No	000b	000b

DMAARB

DMA Arbitration

Bit	Description	Read	Write	Value after Reset	Value to Use
18:0	Reserved.	Yes	(Do not Modify)	0	0
20:19	DMA Channel Priority. Writing 00b indicates a rotational priority scheme. Writing 01b indicates Channel 0 has priority. Writing 10b indicates Channel 1 has priority. Value of 11b is reserved .	Yes	Yes	00b	00b
31:21	Reserved.	Yes	(Do not Modify)	0000 0000 001b	0000 0011 001b

DMATHR

DMA Threshold

Bit	Description	Read	Write	Value after Reset	Value to Use
3:0	DMA Channel 0 PCI-to-Local Almost Full (C0PLAF). Number of full (Lword x 2) entries (plus 1, times 2) in the FIFO before requesting the Local Bus for writes. Nybble values 0h through Eh may be used. (Refer to Table 17.) (15 - C0PLAF) > C0LP AE.	Yes	Yes	0h	x
7:4	DMA Channel 0 Local-to-PCI Almost Empty (C0LP AE). Number of empty (Lword x 2) entries (plus 1, times 2) in the FIFO before requesting the Local Bus for reads. Nybble values 0h through Eh may be used. (Refer to Table 17.) (15 - C0PLAF) > C0LP AE.	Yes	Yes	0h	x
11:8	DMA Channel 0 Local-to-PCI Almost Full (C0LPAF). Number of full (Lword x 2) entries (plus 1, times 2) in the FIFO before requesting the PCI Bus for writes. Nybble values 0h through Eh may be used. (Refer to Table 17.)	Yes	Yes	0h	x

15:12	DMA Channel 0 PCI-to-Local Almost Empty (C0PLAE). Number of empty (Lword x 2) entries (plus 1, times 2) in the FIFO before requesting the PCI Bus for reads. Nybble values 0h through Eh may be used. (Refer to Table 17.)	Yes	Yes	0h	x
19:16	DMA Channel 1 PCI-to-Local Almost Full (C1PLAF). Number of full (Lword x 2) entries (plus 1, times 2) in the FIFO before requesting the Local Bus for writes. Nybble values 0h through Eh may be used. (Refer to Table 17.) (15 - C1PLAF) > C1LPAE.	Yes	Yes	0h	x
23:20	DMA Channel 1 Local-to-PCI Almost Empty (C1LPAE). Number of empty (Lword x 2) entries (plus 1, times 2) in the FIFO before requesting the Local Bus for reads. Nybble values 0h through Eh may be used. (Refer to Table 17.) (15 - C1PLAF) > C1LPAE.	Yes	Yes	0h	x
27:24	DMA Channel 1 Local-to-PCI Almost Full (C1LPAF). Number of full (Lword x 2) entries (plus 1, times 2) in the FIFO before requesting the PCI Bus for writes. Nybble values 0h through Eh may be used. (Refer to Table 17.)	Yes	Yes	0h	x
31:28	DMA Channel 1 PCI-to-Local Almost Empty (C1PLAE). Number of empty (Lword x 2) entries (plus 1, times 2) in the FIFO before requesting the PCI Bus for reads. Nybble values 0h through Eh may be used. (Refer to Table 17.)	Yes	Yes	0h	x

Table 17: DMA Threshold Nybble Values

Nybble Value	Setting	Nybble Value	Setting	Nybble Value	Setting
0h	4 Lwords	5h	24 Lwords	Ah	44 Lwords
1h	8 Lwords	6h	28 Lwords	Bh	48 Lwords
2h	12 Lwords	7h	32 Lwords	Ch	52 Lwords
3h	16 Lwords	8h	38 Lwords	Dh	58 Lwords
4h	20 Lwords	9h	40 Lwords	Eh	60 Lwords

DMADAn

DMA PCI Dual Address Cycle Upper Address

Bit	Description	Read	Write	Value after Reset	Value to Use
31:0	Upper 32 Bits of the PCI Dual Address Cycle PCI Address during DMA Cycles. If set to 0h, the PCI 9056 performs a 32-bit address DMA access.	Yes	Yes	0h	x

INTCSR

Interrupt Control/Status Register

Bit	Description	Read	Write	Value after Reset	Value to Use
0	Writing 1 enables LSERR# to be asserted upon detection of a Local parity error or PCI Abort.	Yes	Yes	0	0
1	Writing 1 enables LSERR# to be asserted upon detection of an SERR# assertion in Host mode, or detection of a PCI parity error or a messaging queue outbound overflow.	Yes	Yes	0	0
2	Generate PCI Bus SERR# Interrupt. When set to 0, writing 1 asserts the PCI Bus SERR# interrupt.	Yes	Yes	0	0
3	Mailbox Interrupt Enable. Writing 1 enables a Local interrupt output (LINTo#) to be asserted when the PCI Bus writes to MBOX0 through MBOX3. To clear a LINTo# interrupt, the Local Bus Master must read the Mailbox. Used in conjunction with the Local Interrupt Output Enable bit (INTCSR[16]).	Yes	Yes	0	0
4	Power Management Interrupt Enable. Writing 1 enables a Local interrupt output (LINTo#) to be asserted when the Power Management Power State changes.	Yes	Yes	0	0
5	Power Management Interrupt. When set to 1, indicates a Power Management interrupt is pending. A Power Management interrupt is caused by a change in the Power Management Control/Status register Power State bits (PMCSR[1:0]). Writing 1 clears the interrupt. Writable from the PCI Bus only in the D0 power state.	Yes	Yes/Clr	0	0
6	Direct Master Write/Direct Slave Read Local Data Parity Check Error Enable. Writing 1 enables a Local Bus Data Parity Error signal to be asserted through the LSERR# pin. INTCSR[0] must be enabled for this to have an effect.	Yes	Yes	0	0
7	Direct Master Write/Direct Slave Read Local Data Parity Check Error Status. When set to 1, indicates the PCI 9056 has detected a Local data parity check error, even if Parity Check Error is disabled (INTCSR[6]=0). Writing 1 clears this bit to 0.	Yes	Yes/Clr	0	0
8	PCI Interrupt Enable. Writing 1 enables PCI interrupts (INTA#).	Yes	Yes	1	1

9	PCI Doorbell Interrupt Enable. Writing 1 enables Local-to-PCI Doorbell interrupts. Used in conjunction with the PCI Interrupt Enable bit (INTCSR[8]). Clearing the L2PDBELL register bits that caused the interrupt also clears the interrupt.	Yes	Yes	0	0
10	PCI Abort Interrupt Enable. Value of 1 enables a Master Abort or Master detection of a Target Abort to assert a PCI interrupt (INTA#). Used in conjunction with the PCI Interrupt Enable bit (INTCSR[8]). Clearing the Received Master and Target Abort bits (PCISR[13:12]) also clears the PCI interrupt.	Yes	Yes	0	0
11	Local Interrupt Input Enable. Writing 1 enables a Local interrupt input (LINTi#) assertion to assert a PCI interrupt (INTA#). Used in conjunction with the PCI Interrupt Enable bit (INTCSR[8]). De-asserting LINTi# also clears the interrupt.	Yes	Yes	0	0
12	Retry Abort Enable. Writing 1 enables the PCI 9056 to treat 256 consecutive Master Retries to a Target as a Target Abort. Writing 0 enables the PCI 9056 to attempt Master Retries indefinitely.	Yes	Yes	0	0
13	PCI Doorbell Interrupt Active. When set to 1, indicates the PCI Doorbell interrupt is active.	Yes	No	0	0
14	PCI Abort Interrupt Active. When set to 1, indicates the PCI Master or Target Abort interrupt is active.	Yes	No	0	0
15	Local Interrupt Input Active. When set to 1, indicates the Local interrupt input (LINTi#) is active.	Yes	No	0	0
16	Local Interrupt Output Enable. Writing 1 enables Local interrupt output (LINTo#).	Yes	Yes	1	1
17	Local Doorbell Interrupt Enable. Writing 1 enables PCI-to-Local Doorbell interrupts. Used in conjunction with the Local Interrupt Output Enable bit (INTCSR[16]). Clearing the P2LDBELL register bits that caused the interrupt also clears the interrupt.	Yes	Yes	0	0
18	DMA Channel 0 Interrupt Enable. Writing 1 enables DMA Channel 0 interrupts. Used in conjunction with the DMA Channel 0 Interrupt Select bit (DMAMODE0[17]). Setting the DMA Channel 0 Clear Interrupt bit (DMACSR0[3]=1) also clears the interrupt.	Yes	Yes	0	0/1
19	DMA Channel 1 Interrupt Enable. Writing 1 enables DMA Channel 1 interrupts. Used in conjunction with the DMA Channel 1 Interrupt Select bit (DMAMODE1[17]). Setting the DMA Channel 1 Clear Interrupt bit (DMACSR1[3]=1) also clears the interrupt.	Yes	Yes	0	0/1
20	Local Doorbell Interrupt Active. Reading 1 indicates the Local Doorbell interrupt is active.	Yes	No	0	0
21	DMA Channel 0 Interrupt Active. Reading 1 indicates the DMA Channel 0 interrupt is active.	Yes	No	0	0
22	DMA Channel 1 Interrupt Active. Reading 1 indicates the DMA Channel 1 interrupt is active.	Yes	No	0	0
23	Built-In Self-Test (BIST) Interrupt Active. Reading 1 indicates the BIST interrupt is active. The BIST interrupt is enabled by writing 1 to the PCI Built-In Self-Test Interrupt Enable bit (PCIBISTR[6]=1). Clearing the Enable bit (PCIBISTR[6]=0) also clears the interrupt. Note: Refer to the PCIBISTR register for a description of the self-test.	Yes	No	0	0

24	Reading 0 indicates the Direct Master was the Bus Master during a Master or Target Abort.	Yes	No	1	1
25	Reading 0 indicates that DMA Channel 0 was the Bus Master during a Master or Target Abort.	Yes	No	1	1
26	Reading 0 indicates that DMA Channel 1 was the Bus Master during a Master or Target Abort.	Yes	No	1	1
27	Reading 0 indicates that the PCI 9056 asserted a Target Abort after 256 consecutive Master Retries to a Target.	Yes	No	1	1
28	Reading 1 indicates that the PCI Bus wrote data to MBOX0. Enabled only if the Mailbox Interrupt Enable bit is set (INTCSR[3]=1).	Yes	No	0	0
29	Reading 1 indicates that the PCI Bus wrote data to MBOX1. Enabled only if the Mailbox Interrupt Enable bit is set (INTCSR[3]=1).	Yes	No	0	0
30	Reading 1 indicates that the PCI Bus wrote data to MBOX2. Enabled only if the Mailbox Interrupt Enable bit is set (INTCSR[3]=1).	Yes	No	0	0
31	Reading 1 indicates that the PCI Bus wrote data to MBOX3. Enabled only if the Mailbox Interrupt Enable bit is set (INTCSR[3]=1).	Yes	No	0	0

7 Troubleshooting

If you are having problems with your system, please try the following initial steps:

- **Simplify the System** – Remove modules one at a time from your system to see if there is a specific module that is causing a problem. Perform your troubleshooting with the least number of modules in the system possible.
- **Swap Components** – Try replacing parts in the system one at a time with similar parts to determine if a part is faulty or if a type of part is configured incorrectly.

If problems persist, or you have questions about configuring this product, contact RTD Embedded Technologies via the following methods:

Phone: +1-814-234-8087
E-Mail: techsupport@rtd.com

Be sure to check the RTD web site (<http://www.rtd.com>) frequently for product updates, including newer versions of the board manual and application software.

8 Additional Information

8.1 PC/104 Specifications

A copy of the latest PC/104 specifications can be found on the webpage for the PC/104 Embedded Consortium:

www.pc104.org

8.2 PCI and PCI Express Specification

A copy of the latest PCI and PCI Express specifications can be found on the webpage for the PCI Special Interest Group:

www.pcisig.com

8.3 PLX PCI9056

For more information about the PLX PCI9056 PCI Accelerator, contact PLX Technologies at:

www.plxtech.com

8.4 82C54 Timer/Counter Programming

For more information about programming the MSM82C54 Timer/Counter Chips, contact Oki Semiconductor at:

www2.okisemi.com

8.5 Interrupt Programming

For more information about interrupts and writing interrupt service routines, refer to the following book:

Interrupt-Driven PC System Design
by Joseph McGivern
ISBN: 0929392507

9 Limited Warranty

RTD Embedded Technologies, Inc. warrants the hardware and software products it manufactures and produces to be free from defects in materials and workmanship for one year following the date of shipment from RTD Embedded Technologies, Inc. This warranty is limited to the original purchaser of product and is not transferable.

During the one year warranty period, RTD Embedded Technologies will repair or replace, at its option, any defective products or parts at no additional charge, provided that the product is returned, shipping prepaid, to RTD Embedded Technologies. All replaced parts and products become the property of RTD Embedded Technologies. Before returning any product for repair, customers are required to contact the factory for a Return Material Authorization (RMA) number.

This limited warranty does not extend to any products which have been damaged as a result of accident, misuse, abuse (such as: use of incorrect input voltages, improper or insufficient ventilation, failure to follow the operating instructions that are provided by RTD Embedded Technologies, "acts of God" or other contingencies beyond the control of RTD Embedded Technologies), or as a result of service or modification by anyone other than RTD Embedded Technologies. Except as expressly set forth above, no other warranties are expressed or implied, including, but not limited to, any implied warranties of merchantability and fitness for a particular purpose, and RTD Embedded Technologies expressly disclaims all warranties not stated herein. All implied warranties, including implied warranties for merchantability and fitness for a particular purpose, are limited to the duration of this warranty. In the event the product is not free from defects as warranted above, the purchaser's sole remedy shall be repair or replacement as provided above. Under no circumstances will RTD Embedded Technologies be liable to the purchaser or any user for any damages, including any incidental or consequential damages, expenses, lost profits, lost savings, or other damages arising out of the use or inability to use the product.

Some states do not allow the exclusion or limitation of incidental or consequential damages for consumer products, and some states do not allow limitations on how long an implied warranty lasts, so the above limitations or exclusions may not apply to you.

This warranty gives you specific legal rights, and you may also have other rights which vary from state to state.

RTD Embedded Technologies, Inc.

103 Innovation Boulevard
State College, PA 16803 USA
Telephone: 814-234-8087
Fax: 814-234-5218

www.rtd.com

sales@rtd.com
techsupport@rtd.com

