



# Line Drivers/Receivers

DM7830/DM8830

## DM7830/DM8830 dual differential line driver

### general description

The DM7830/DM8830 is a dual differential line driver that also performs the dual four-input NAND or dual four-input AND function.

TTL (Transistor-Transistor-Logic) multiple emitter inputs allow this line driver to interface with standard TTL or DTL systems. The differential outputs are balanced and are designed to drive long lengths of coaxial cable, strip line, or twisted pair transmission lines with characteristic impedances of 50Ω to 500Ω. The differential feature of the output eliminates troublesome ground-loop errors

normally associated with single-wire transmissions.

### features

- Single 5 volt power supply
- Diode protected outputs for termination of positive and negative voltage transients
- Diode protected inputs to prevent line ringing
- High Speed
- Short Circuit Protection

### schematic\* and connection diagrams

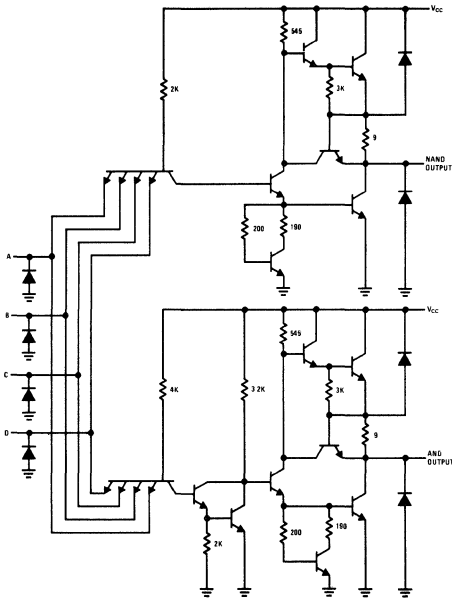

\*2 PER PACKAGE.

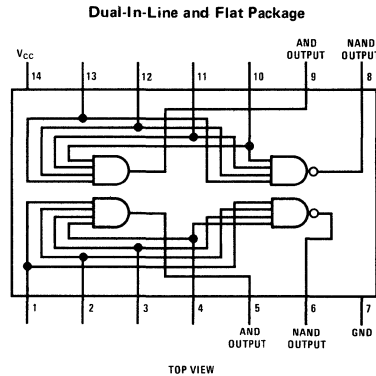

Order Number DM7830J or DM8830J  
See Package 16

Order Number DM8830N  
See Package 22

Order Number DM7830W or DM8830W  
See Package 27

### typical application

#### Digital Data Transmission

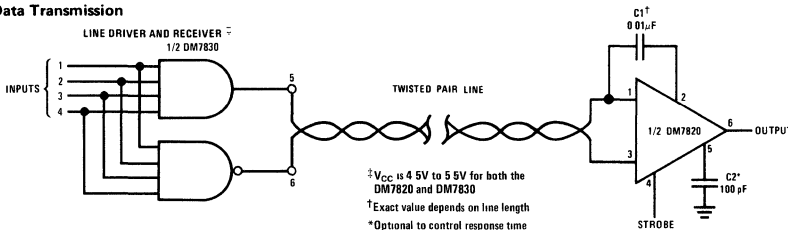

4

### absolute maximum ratings

$V_{CC}$		7.0V
Input Voltage		5.5V
Operating Temperature	DM7830	-55°C to +125°C
	DM8830	0°C to 70°C
Storage Temperature		-65°C to +150°C
Lead Temperature (Soldering, 10 sec)		300°C
Output Short Circuit Duration (125°C)		1 second

### electrical characteristics (Note 1)

PARAMETER	CONDITIONS	MIN	TYP	MAX	UNITS	
Logical "1" Input Voltage		2.0			V	
Logical "0" Input Voltage				0.8	V	
Logical "1" Output Voltage	$V_{IN} = 0.8V$ $I_{OUT} = -0.8$ mA	2.4			V	
Logical "1" Output Voltage	$V_{IN} = 0.8V$ $I_{OUT} = 40$ mA	1.8	3.3		V	
Logical "0" Output Voltage	$V_{IN} = 2.0V$ $I_{OUT} = +32$ mA		0.2	0.4	V	
Logical "0" Output Voltage	$V_{IN} = 2.0V$ $I_{OUT} = +40$ mA		0.22	0.5	V	
Logical "1" Input Current	$V_{IN} = +2.4V$			120	$\mu$ A	
Logical "1" Input Current	$V_{IN} = 5.5V$			2	mA	
Logical "0" Input Current	$V_{IN} = 0.4V$			4.8	mA	
Output Short Circuit Current	$V_{CC} = 5.0V$ $T_A = 125^\circ C$	40	100	120	mA	
Supply Current	$V_{IN} = 5.0V$ (Each Driver)		11	18	mA	
Propagation Delay AND Gate	$t_{pd1}$ } $T_A = 25^\circ C$ $t_{pd0}$ } $V_{CC} = 5.0V$ Propagation Delay NAND Gate } $C_L = 15$ pF $t_{pd1}$ } See Figure 1 $t_{pd0}$ }		8	12	ns	
				11	18	ns
				8	12	ns
				5	8	ns
Differential Delay $t_1$	$t_1$ } Load, 100 $\Omega$ and 5000 pF $t_2$ } See Figure 2		12	16	ns	
Differential Delay $t_2$			12	16	ns	

**Note 1:** Specifications apply for DM7830  $-55^\circ C \leq T_A \leq +125^\circ C$ ,  $V_{CC} = +5V \pm 10\%$ , DM8830  $0^\circ C \leq T_A \leq 70^\circ C$ ,  $V_{CC} = +5V \pm 5\%$  unless otherwise stated. Typical values given are for  $T_A = 25^\circ C$ ,  $V_{CC} = 5.0V$ .

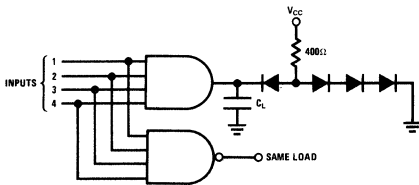

FIGURE 1.

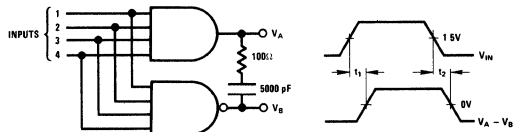
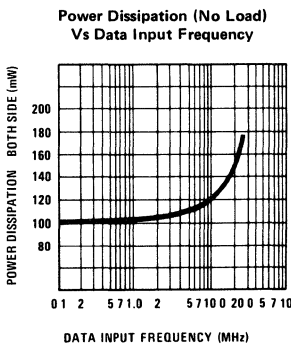
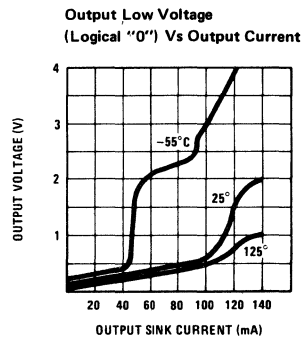
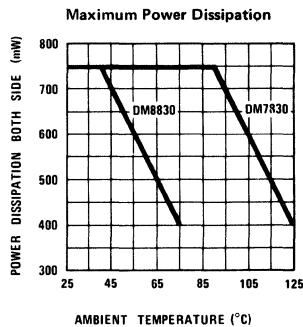
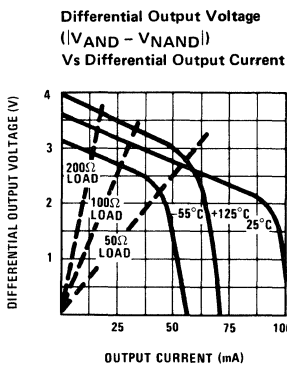
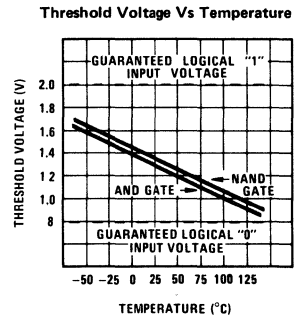
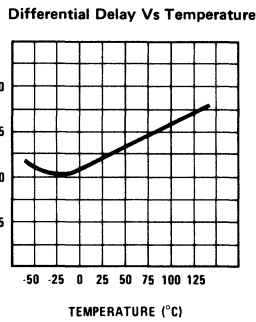
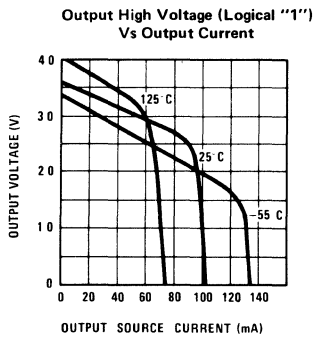
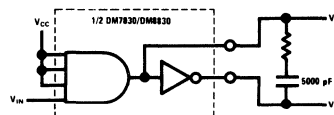

FIGURE 2.

typical performance characteristics



ac test circuit



switching time waveforms

