



# Line Drivers/Receivers

DM7820/DM8820

## DM7820/DM8820 dual line receiver

### general description

The DM7820, specified from  $-55^{\circ}\text{C}$  to  $125^{\circ}\text{C}$ , and the DM8820, specified from  $0^{\circ}\text{C}$  to  $70^{\circ}\text{C}$ , are digital line receivers with two completely independent units fabricated on a single silicon chip. Intended for use with digital systems connected by twisted pair lines, they have a differential input designed to reject large common mode signals while responding to small differential signals. The output is directly compatible with RTL, DTL or TTL integrated circuits.

### features

- Operation from a single +5V logic supply
- Input voltage range of  $\pm 15\text{V}$

- Each channel can be strobed independently
- High input resistance
- Fanout of two with either DTL or TTL integrated circuits

The response time can be controlled with an external capacitor to eliminate noise spikes, and the output state is determined for open inputs. Termination resistors for the twisted pair line are also included in the circuit. Both the DM7820 and the DM8820 are specified, worst case, over their full operating temperature range, for  $\pm 10$ -percent supply voltage variations and over the entire input voltage range.

## schematic and connection diagrams

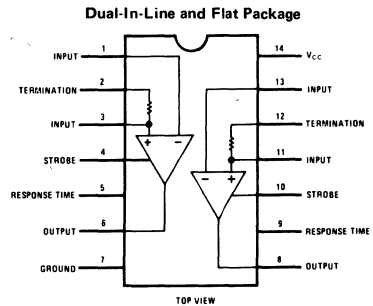
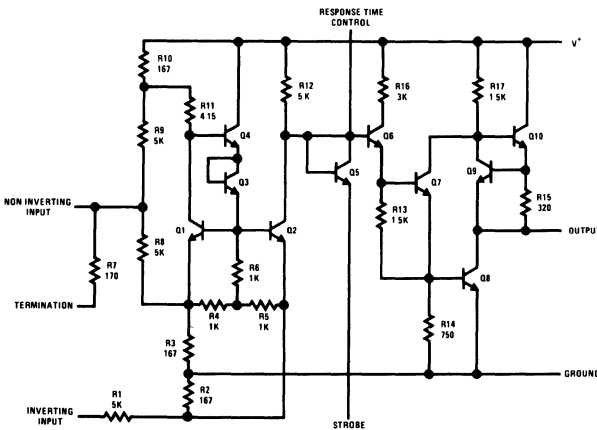

Order Number DM7820J or DM8820J  
See Package 16

Order Number DM8820N  
See Package 22

Order Number DM7820W or DM8820W  
See Package 27

## typical application

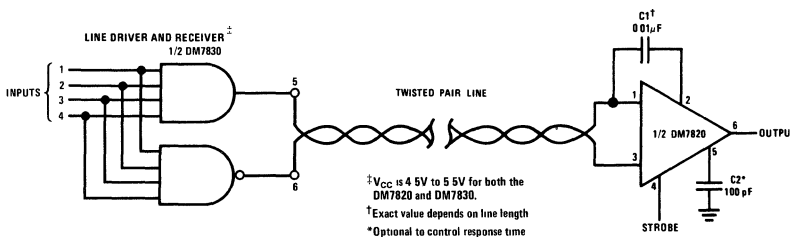

4

**absolute maximum ratings**

Supply Voltage	8.0V
Input Voltage	±20V
Differential Input Voltage	±20V
Strobe Voltage	8.0V
Output Sink Current	25 mA
Power Dissipation (Note 1)	600 mW
Operating Temperature Range	
DM7820	-55°C to +125°C
DM8820	0°C to +70°C
Storage Temperature Range	-65°C to +150°C
Lead Temperature (Soldering, 10 sec)	300°C

**electrical characteristics** (Notes 2 & 3)

PARAMETER	CONDITIONS	MIN	TYP	MAX	UNITS
Input Threshold Voltage	$V_{IN} = 0$	-0.5	0	0.5	V
	$-15V \leq V_{IN} \leq 15V$	-1.0	0	1.0	V
High Output Level	$I_{OUT} \leq 0.2 \text{ mA}$	2.5		5.5	V
Low Output Level	$I_{sink} \leq 3.5 \text{ mA}$	0		0.4	V
Inverting Input Resistance		3.6	5.0		kΩ
Non-inverting Input Resistance		1.8	2.5		kΩ
Line Termination Resistance	$T_A = 25^\circ\text{C}$	120	170	250	Ω
Response Time	$C_{delay} = 0$		40		ns
	$C_{delay} = 100 \text{ pF}$		150		ns
Strobe Current	$V_{strobe} = 0.4V$		1.0	1.4	mA
	$V_{strobe} = 5.5V$			-5.0	μA
Power Supply Current	$V_{IN} = 15V$		3.2	6.0	mA
	$V_{IN} = 0$		5.8	10.2	mA
	$V_{IN} = -15V$		8.3	15.0	mA
Non-inverting Input Current	$V_{IN} = 15V$		5.0	7.0	mA
	$V_{IN} = 0$	-1.6	-1.0		mA
	$V_{IN} = -15V$	-9.8	-7.0		mA
Inverting Input Current	$V_{IN} = 15V$		3.0	4.2	mA
	$V_{IN} = 0$		0	-0.5	mA
	$V_{IN} = -15V$	-4.2	-3.0		mA

**Note 1:** For operating at elevated temperatures, the device must be derated based on a thermal resistance of 100°C/W and a maximum junction temperature of 160°C for the DM7820 or 105°C for the DM8820.

**Note 2:** These specifications apply for  $4.5V \leq V_{CC} \leq 5.5V$ ,  $-15V \leq V_{CM} \leq 15V$  and  $-55^\circ\text{C} \leq T_A \leq 125^\circ\text{C}$  for the DM7820 or  $0^\circ\text{C} \leq T_A \leq 70^\circ\text{C}$  for the DM8820 unless otherwise specified; typical values given are for  $V_{CC} = 5.0V$ ,  $T_A = 25^\circ\text{C}$  and  $V_{CM} = 0$  unless stated differently.

**Note 3:** The specifications and curves given are for one side only. Therefore, the total package dissipation and supply currents will be double the values given when both receivers are operated under identical conditions.

typical performance characteristics (Note 3)

Supply Voltage Sensitivity

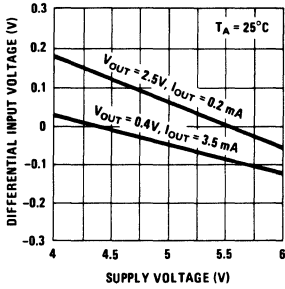

Common Mode Rejection

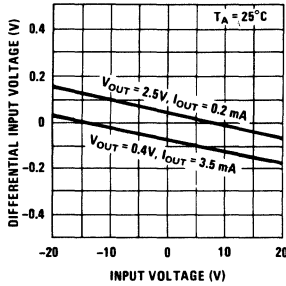

Transfer Function

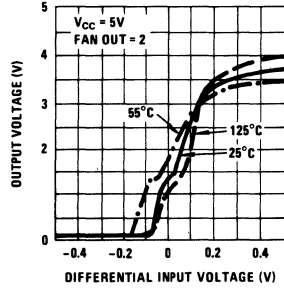

Response Time

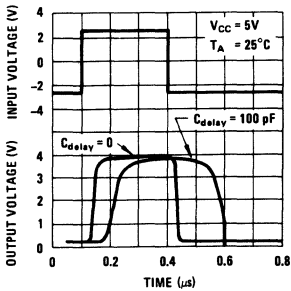

Output Voltage Levels

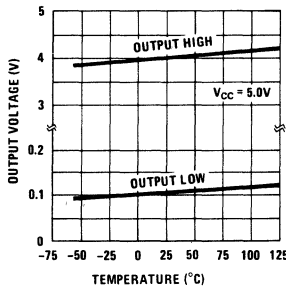

Termination Resistance

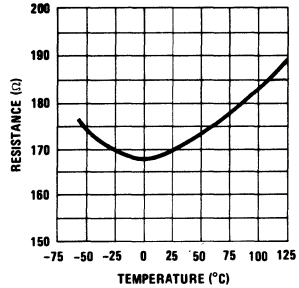

Positive Supply Current

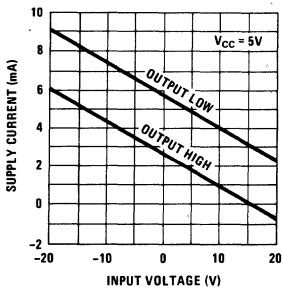

Internal Power Dissipation

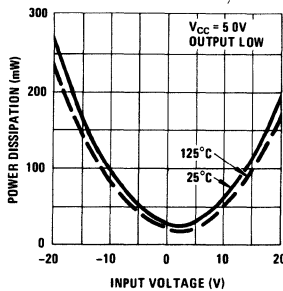

Maximum Power Dissipation

