



Display Drivers

DM7887/DM8887, DM7889/DM8889, DM7897/DM8897

DM7887/DM8887 8-digit high voltage anode driver (active-high inputs)

DM7889/DM8889 8-digit high voltage cathode driver (active-high inputs)

DM7897/DM8897 8-digit high voltage anode driver (active-low inputs)

general description

The DM7887/DM8887 and DM7897/DM8897 are designed to drive the individual anodes of a seven segment (cathodes) high-voltage gas discharge panel in a time multiplexed fashion.

When driven with appropriate input signals, the driver will switch voltage and impedance levels at the anode. This will allow or prevent ionization of gas around selected cathode in order to form a numeric display. Their main application will be to act as buffers between MOS outputs (fully-decoded) and the anodes of a gas-discharge panel, since the devices can source up to 16 mA at a low impedance and can tolerate more than 55V in the off state.

DM7889/DM8889 is capable of driving eight segments of a high-voltage display tube with a

constant output sink current, which can be adjusted by external program resistor, R_P . The program current is half that of output on current. In the "OFF" state the outputs can tolerate more than 80V. The ratio of "ON" output currents is within $\pm 10\%$. Inputs have negative clamp diodes. Active high input logic. The main application of the device is to interface MOS circuits to high-voltage displays. The total power dissipation in the package is low.

features

- Versatile circuits for a wide range of display applications
- High breakdown voltages
- Low power dissipation

connection diagrams (dual-in-line packages)

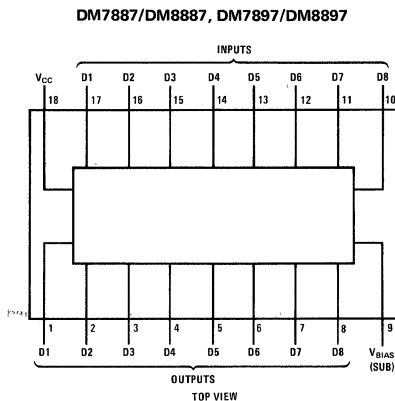

Order Number **DM7887J** or **DM8887J**
See Package 24
Order Number **DM8887N**
See Package 25

Order Number **DM7897J** or **DM8897J**
See Package 24
Order Number **DM8897N**
See Package 25

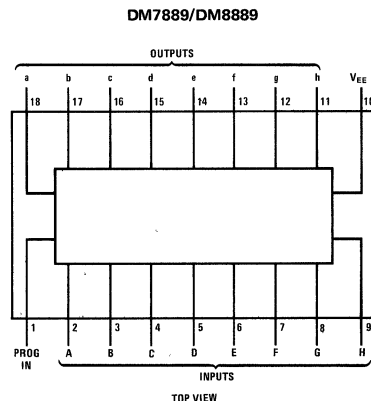

Order Number **DM7889J** or **DM8889J**
See Package 24
Order Number **DM8889N**
See Package 25

6

absolute maximum ratings (Note 1)

Supply Voltage ($V_{CC} - V_{BIAS}$) (Note 2)	
DM7887/DM8887, DM7897/DM8897	-60V
Package Power	
DM7889/DM8889	600 mW
Input Voltage	
DM7887/DM8887, DM7897/DM8897	-20V
DM7889/DM8889 (Note 3)	35V
Output Voltage	
DM7887/DM8887, DM7897/DM8897	-65V
DM7889/DM8889	85V
Storage Temperature Range	-65°C to +150°C
Lead Temperature (Soldering, 10 seconds)	300°C

operating conditions

	MIN	MAX	UNITS
Supply Voltage ($V_{CC} - V_{BIAS}$)			
DM7887/DM8887, DM7897/DM8897	-40	-60	V
Temperature (T_A)			
DM7887, DM7889, DM7897	-55	+125	°C
DM8887, DM8889, DM8897	0	+70	°C

dc electrical characteristics (Notes 2, 3 and 4)

PARAMETER	CONDITIONS	MIN	TYP	MAX	UNITS
DM8887, DM8897					
Logical "1" Input Voltage DM8887	$V_{OUT} = -1.4V, I_{OUT} = -16\text{ mA}$	-2.0			V
Logical "0" Input Voltage DM8887	$V_{OUT} = -60V, I_{OUT} = -100\mu A$			-5.5	V
Logical "1" Input Current DM8897	$V_{OUT} = -1.4, I_{OUT} = -16\text{ mA}$	-300			μA
Logical "0" Input Current DM8897	$V_{OUT} = -60V, I_{OUT} = -100\mu A$			-10	μA
Input Current DM8887	$V_{IN} = -1.0V$ $V_{IN} = -6.0V$		335 -0.2	550 -25	μA μA
DM8897	$V_{IN} = -12V$ $V_{IN} = -12V$	-0.30 -0.6		-0.65 -1.5	mA mA
Output Off Voltage	$I_{OUT} = -100\mu A, I_{IN} = 0\mu A$	-60	-77		V
Output Off Current	$V_{OUT} = -55V, I_{IN} = 0\mu A$		-0.03	-5.0	μA
Output On Voltage DM8887	$V_{IN} = -2.0V, I_{OUT} = -16\text{ mA}$		-1.0	-1.4	V
DM8897	$I_{IN} = -300\mu A, I_{OUT} = -16\text{ mA}$			-1.4	V
Supply Current DM8887 (Note 5)	$V_{IN} = -1.0V, I_{OUT} = -16\text{ mA}, V_{BIAS} = -60V$		-2.2	-4.0	mA
DM8897	$I_{IN} = -300\mu A, I_{OUT} = -16\text{ mA}, V_{BIAS} = -60V,$ (One Driver Only)			-100	μA
DM7889/DM8889					
Input Current	$V_{IN} = 6.0V$	150	250	350	μA
Logical "0" Input Current	$I_{OUT} = 5.0\mu A, V_{OUT} = 75V$			7.0	μA
Logical "1" Input Current	$I_{OUT} = 1.4\text{ mA}, I_{IP} = 850\mu A, V_{OUT} = 50V$	80			μA
Input Clamp Voltage	$I_{IN} = -1.0\text{ mA}, T_A = 25^\circ C$		-0.68	-0.85	V
Output Breakdown Voltage	$I_{OUT} = 100\mu A, I_{IN} = 0\mu A$	80			V
Output Leakage Current	$V_{OUT} = 75V, -1.0\text{ mA} \leq I_{IN} \leq 7.0\mu A$		0.02	5.0	μA
Prog. Input Voltage	$I_{IP} = 150\mu A$ $I_{IP} = 850\mu A$	1.8	2.3 4.0	4.5	V V
Logical "0" Output Current DM7889	$V_{OUT} = 50V, 80\mu A \leq I_{IN} \leq I_{IP}$ $I_{IP} = 150\mu A$	210	300	390	μA
DM8889	$I_{IP} = 150\mu A$	240	300	360	μA
DM7889	$I_{IP} = 400\mu A$	660	800	940	μA
DM8889	$I_{IP} = 400\mu A$	680	800	920	μA
DM7889	$I_{IP} = 850\mu A$	1.45	1.7	1.95	mA
DM8889	$I_{IP} = 850\mu A$	1.53	1.7	1.87	mA
Output Current Ratio	$I_{OUT} \text{ 'b' Ref} = 1.7\text{ mA}, V_{OUT} = 50V$	0.9	1.0	1.1	

ac electrical characteristics $T_A = 25^\circ\text{C}$ unless otherwise specified.

PARAMETER	CONDITIONS	MIN	TYP	MAX	UNITS
DM8887					
Propagation Delay from Input to Output "ON" (t_{ON})	(See AC Test Circuit and Switching Time Waveforms)			5.0	μs
Propagation Delay from Input to Output "ON" (t_{RISE})				1.0	μs
DM7889/DM8889					
Propagation Delay to a Logical "0" from Input to Output (t_{pd0})	$R_p = 6.0\text{k}\Omega$ to 6.0V , $R_{OUT} = 1.0\text{k}\Omega$ to 6.0V		37	100	ns
Propagation Delay to a Logical "1" from Input to Output (t_{pd1})	Input Ramp Rate $\leq 15\text{ ns}$, Freq = 1.0 MHz , DC = 50%, Amplitude = 6.0V		92	200	ns

Note 1: "Absolute Maximum Ratings" are those values beyond which the safety of the device cannot be guaranteed. Except for "Operating Temperature Range" they are not meant to imply that the devices should be operated at these limits. The table of "Electrical Characteristics" provides conditions for actual device operation.

Note 2: All voltages shown for DM7887/DM8887, DM7897/DM8897 W R T $V_{CC} = 0\text{V}$. All currents into device pins shown as positive, out of device pins as negative. All values shown as max or min on absolute value basis.

Note 3: All voltages for DM7889/DM8889 with respect to $V_{EE} = 0\text{V}$.

Note 4: Unless otherwise specified min/max limits apply across the -55°C to $+125^\circ\text{C}$ temperature range for the DM7889 and across the 0°C to $+70^\circ\text{C}$ range for the DM8887, DM8889 and DM8897. All typical values are given for $T_A = 25^\circ\text{C}$.

Note 5: Supply currents specified for any one input = -1.0V . All other inputs = -5.5V and selected output having 16 mA load.

typical application

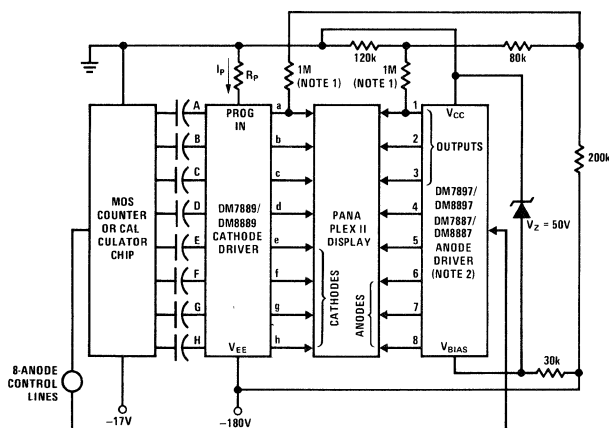

NOTE 1 ALL OUTPUTS OF BOTH CATHODE AND ANODE DRIVER HAVE LOADS AS SHOWN FOR OUTPUT a

NOTE 2 USE DM7887/DM8887 FOR ACTIVE HIGH INPUTS AND DM7897/DM8897 FOR ACTIVE LOW INPUTS

typical performance characteristics

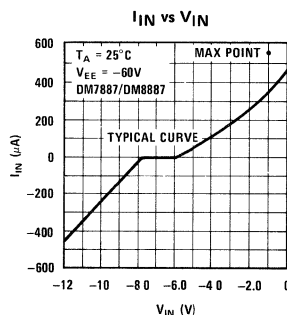

ac test circuit and switching time waveforms

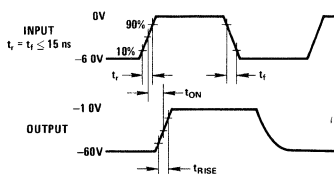
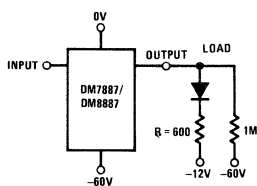

logic diagrams

