

Gigabit Copper Ethernet Transceiver

The Davicom DM9701F is a standalone, low-power 10BASE-T/100BASE-TX/1000BASE-T Gigabit Ethernet physical layer (PHY) transceiver that is fully compliant with the IEEE 802.3 and 802.3ab standards.

The PHY is implemented using an advanced DSP architecture that delivers superior performance and noise immunity.

The DM9701F includes an internal hybrid, and can be connected to a CAT-5 UTP or CAT-3 UTP (10 Mbps only) cable through common magnetics.

It also supports several Ethernet MAC interfaces, including the standard IEEE Medium Independent Interface (GMII/MII), RGMII (which is a reduced 12-pin version of the 25-pin GMII), Ten Bit Interface (TBI), and the Reduced TBI (RTBI).

Several power management modes are incorporated into the DM9701F to reduce power consumption, including Wake-on-LAN, energy detect power-down, and Power Optimizer™ functions. The Power Optimizer™ function enables the PHY to automatically optimize power consumption based on the operating mode and cable quality.

The DM9701F is fully compliant with the IEEE 802.3 standard for auto-negotiation and also includes support for the Speed Optimizer™ function. Speed Optimizer™ maximizes throughput by examining the quality of the cable and establishing the maximum speed that the link can reliability support.

In addition to this feature, the DM9701F includes a Cable Length Estimator function that provides first-level-cable diagnostics.



Key Features:

- Fully standard compliant with:
 - IEEE 802.3ab 1000BASE-T
 - IEEE 802.3u (Fast Ethernet)
 - ISO 802-3/IEEE 802.3 (10BASE-T)
- Full auto-negotiation
- Half- and Full-duplex operation
- MAC Interface options: GMII, MII, RGMII,
- TBI, and RTBI
- Auto Crossover detection for all modes
- Auto detection and correction of pair swap
- (complete or half swap), and polarity
- Jumbo packet support
- Speed Optimizer mechanism
- Power Optimizer function
- Energy detect power-down
- Cable diagnostics function
- Internal hybrid
- Low power consumption (1.5 watts)

DM9701F System Block Diagram

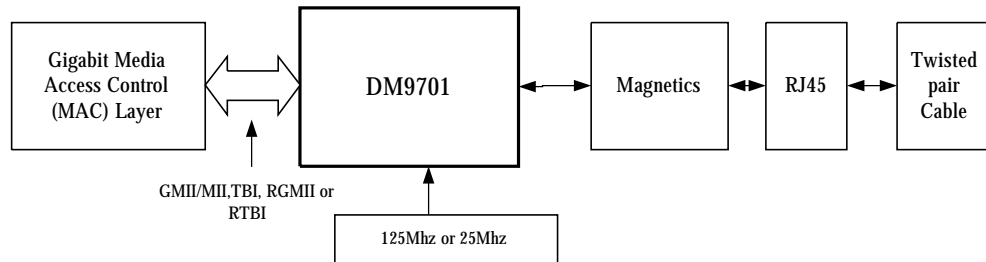

DM9701F Block Diagram

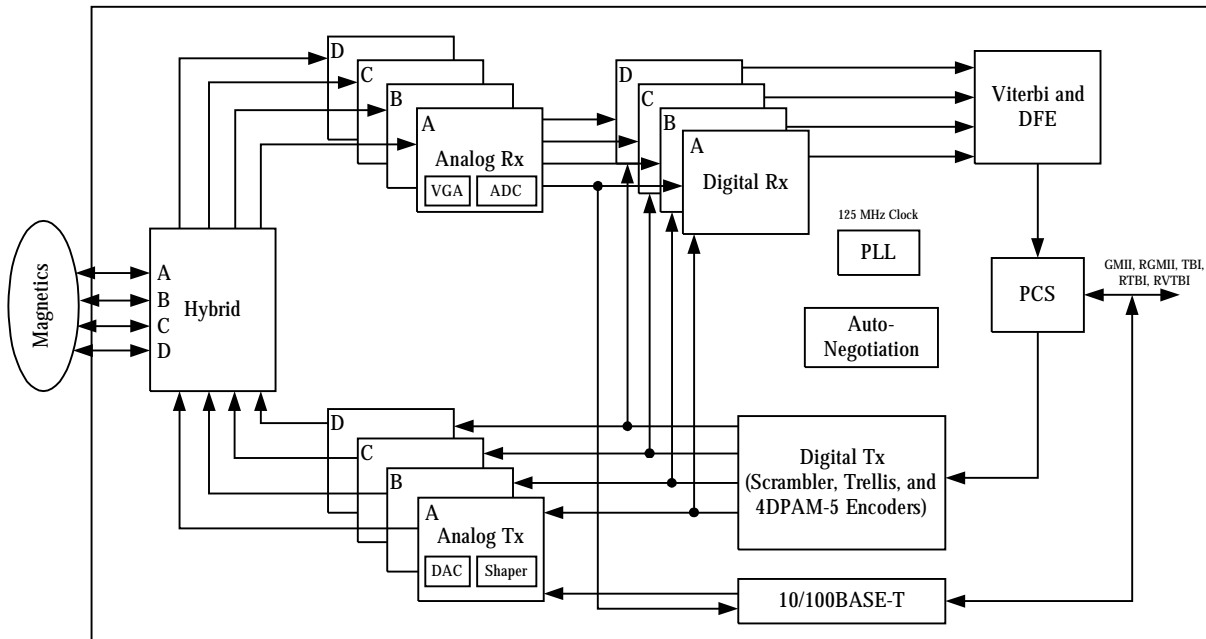



DM9701F

Gigabit Ethernet PHY Transceiver

Additional Features:

- Supports CAT-5 UTP for 1000BASE-T and 100BASE-TX, and CAT-3 and CAT-5 UTP for 10BASE-T
- 125 MHz free-running clock output
- Low-jitter PLL
- Enhanced testability (such as JTAG and Loopback)
- Interrupt support
- Analog network interface to common magnetic for 10/100/1000 Mbps operation
- Standard 0.15-micron digital CMOS process
- 3.3 and 1.5V voltage supplies
- 128-pin PQFP package