

# Timers Multifunction Type DMB51



- Selectable timerange 0.1 s to 100 h
- 7 knob selectable functions:
  - Op - delay on operate
  - In - interval
  - Io - interval on trigger open
  - Id - double interval
  - Dr - delay on release
  - R - symmetrical recycler ON first
  - Rb - symmetrical recycler OFF first
- Automatic or manual start
- Repeatability:  $\leq 0.2\%$
- Output: 8 A SPDT relay
- For mounting on DIN-rail in accordance with DIN/EN 50 022
- 17.5 mm DIN-rail housing
- Combined AC and DC power supply
- LED indication for relay status and power supply ON

## Product Description

Multi-voltage timer with 7 knob-selectable functions and 7 knob-selectable time ranges within 0.1s and 100h. For mounting on DIN-rail. 17.5 mm wide housing suitable both for back and front panel mounting.

## Ordering Key

**DMB 51 C M24**

Housing \_\_\_\_\_  
 Function \_\_\_\_\_  
 Type \_\_\_\_\_  
 Item number \_\_\_\_\_  
 Output \_\_\_\_\_  
 Power supply \_\_\_\_\_

## Type Selection

Mounting	Output	Housing
DIN-rail	SPDT	Mini-D

Supply: 24 VDC and 24 to 240 VAC

**DMB51CM24**

## Time Specifications

<b>Time ranges</b> Knob selectable	0.1 to 1 s 1 to 10 s 6 to 60 s 60 to 600 s 0.1 to 1 h 1 to 10 h 10 to 100 h
<b>Setting accuracy</b>	$\leq 5\%$
<b>Repeatability</b>	$\leq 0.2\%$
<b>Time variation</b> Within rated power supply Within ambient temperature	$\leq 0.05\%/V$ $\leq 0.2\%/^{\circ}C$
<b>Reset</b> Manual reset of time and/or relay Pulse duration Power supply interruption	Close the trigger contact between pins A1 and Y1 $\geq 100$ ms $\geq 200$ ms

## Output Specifications

<b>Output</b>	SPDT relay
<b>Rated insulation voltage</b>	250 VAC (rms)
<b>Contact Ratings (AgSnO<sub>2</sub>)</b>	$\mu$
Resistive loads	AC 1 8 A @ 250 VAC DC 12 5 A @ 24 VDC
Small inductive loads	AC 15 2.5 A @ 250 VAC DC 13 2.5 A @ 24 VDC
<b>Mechanical life</b>	$\geq 30 \times 10^6$ operations
<b>Electrical life</b>	$\geq 10^5$ operations (at 8 A, 250 V, $\cos \varphi = 1$ )
<b>Operating frequency</b>	$< 7200$ operations/h
<b>Dielectric strength</b>	
Dielectric voltage	2 kVAC (rms)
Rated impulse withstand voltage	2.5 kV (1.2/50 $\mu$ s)

www.DataSheet4U.com

## Supply Specifications

<b>Power supply</b> Rated operational voltage through terminals: A1, A2	Overvoltage cat. II (IEC 60664, IEC 60038)  24 VDC $\pm$ 15% and 24 to 240 VAC + 10% -15%, 45 to 65 Hz
<b>Voltage interruption</b>	$\leq$ 10 ms
<b>Rated operational power</b>	1.5 W

## Time Setting

<b>Upper knob:</b> Setting of function: Op - delay on operate In - interval Io - interval on trigger open Id - double interval Dr - delay on release R - symmetrical recycler (ON first) Rb - symmetrical recycler (OFF first)	<b>Centre knob:</b> Time setting on relative scale: 10 to 110% on full scale  <b>Lower knob:</b> Setting of time range
--	--

## Mode of Operation

### Function Op

#### Delay on operate

The time period begins as soon as the trigger contact is closed.

At the end of the set delay time the relay operates and does not release until the trigger contact is closed again or the power supply is disconnected. If the trigger contact is closed before the end of the delay time, the device resets and a new time period starts.

### Function In

#### Interval

The relay operates and the time period begins as soon as the trigger contact is closed. The relay releases at the end of this period or when the power supply is disconnected. The relay operates again when the trigger contact is closed again. If the trigger contact is closed before the end of the delay time, the device resets and a new time period starts.

### Function Io

#### Interval on trigger open

The relay operates and the time period begins as soon as the trigger contact is opened. At the end of the set delay or when the power supply is disconnected the relay releases. The relay operates again when the trigger contact is opened again. If the trigger contact is opened before the end of the delay time the relay keeps ON and a new time period begins.

### Function Id

#### Double interval

The relay operates and the time period begins as soon as the trigger contact is closed. The relay releases at the end of this period or when the power supply is disconnected. When the trigger contact is opened the relay operates again for the set delay period. If the trigger contact is opened before the end of the first time period the second one begins; if the trigger contact is closed before the end of

## General Specifications

<b>Power ON delay</b>	$\leq$ 100 ms
<b>Indication for</b> Power supply status Output status	LED, green LED, yellow (flashing when timing)
<b>Environment</b> Degree of protection Pollution degree Operating temperature Storage temperature	(EN 60529) IP 20 2 (IEC 60664) -20° to +60°C, R.H. < 95% -30° to +80°C, R.H. < 95%
<b>Weight</b>	75 g
<b>Screw terminals</b> Tightening torque	Max. 0.5 Nm according to IEC 60947
<b>Approval</b>	UL
<b>EMC</b> Immunity Emission	Electromagnetic Compatibility According to EN 50082-2 According to EN 50082-1

the second time period the device resets and the first time period begins again.

### Function Dr

#### Delay on release

The relay operates as soon as the trigger contact is closed. The time period begins when the trigger contact is opened. The relay releases at the end of the set delay time or when the power supply is disconnected. The relay operates again when the input contact is closed again. If it is opened before the end of the delay time the relay keeps ON, a new time period begins as soon as the contact is closed again.

### Function R

#### Symmetrical recycler, ON-time period first

The relay operates and the time period begins as soon as the input contact is closed. After the set delay period the relay releases for the same time period. This sequence continues with equal ON- and OFF-time

periods until the power supply is interrupted.

### Function Rb Symmetrical recycler, OFF-time period first

The time period begins as soon as the input contact is closed. The relay is OFF during the set delay period, after this time it operates for the same time period. This sequence continues with equal OFF- and ON-time periods until the power supply is interrupted.

### Additional Load

It's possible to wire an additional load (i.e. a relay) between pins Y1 and A2, driven by the trigger contact without damaging the device.

### Yellow LED working mode

Timing: Slow blinking  
Relay ON: See operation diagrams  
Incorrect knobs position: Fast blinking

## Wiring Diagram

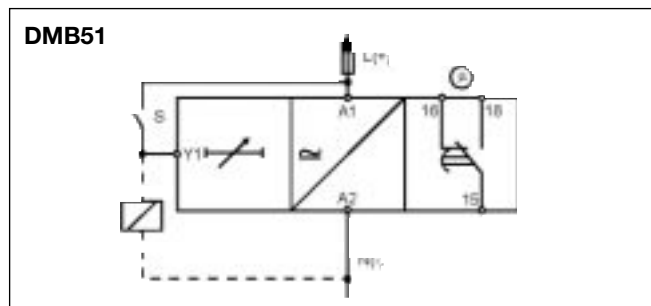

## Operating Diagrams

