

Features

- Extremely low collector-to-emitter saturation voltage
($V_{CE(SAT)} = 0.1V$ Typ. @ $I_C/I_B = 100mA/10mA$)
- Suitable for low voltage large current drivers
- Complementary pair with DP030
- Switching Application

Ordering Information

Type NO.	Marking	Package Code
DN030	DNO30	TO-92

Outline Dimensions

unit : mm

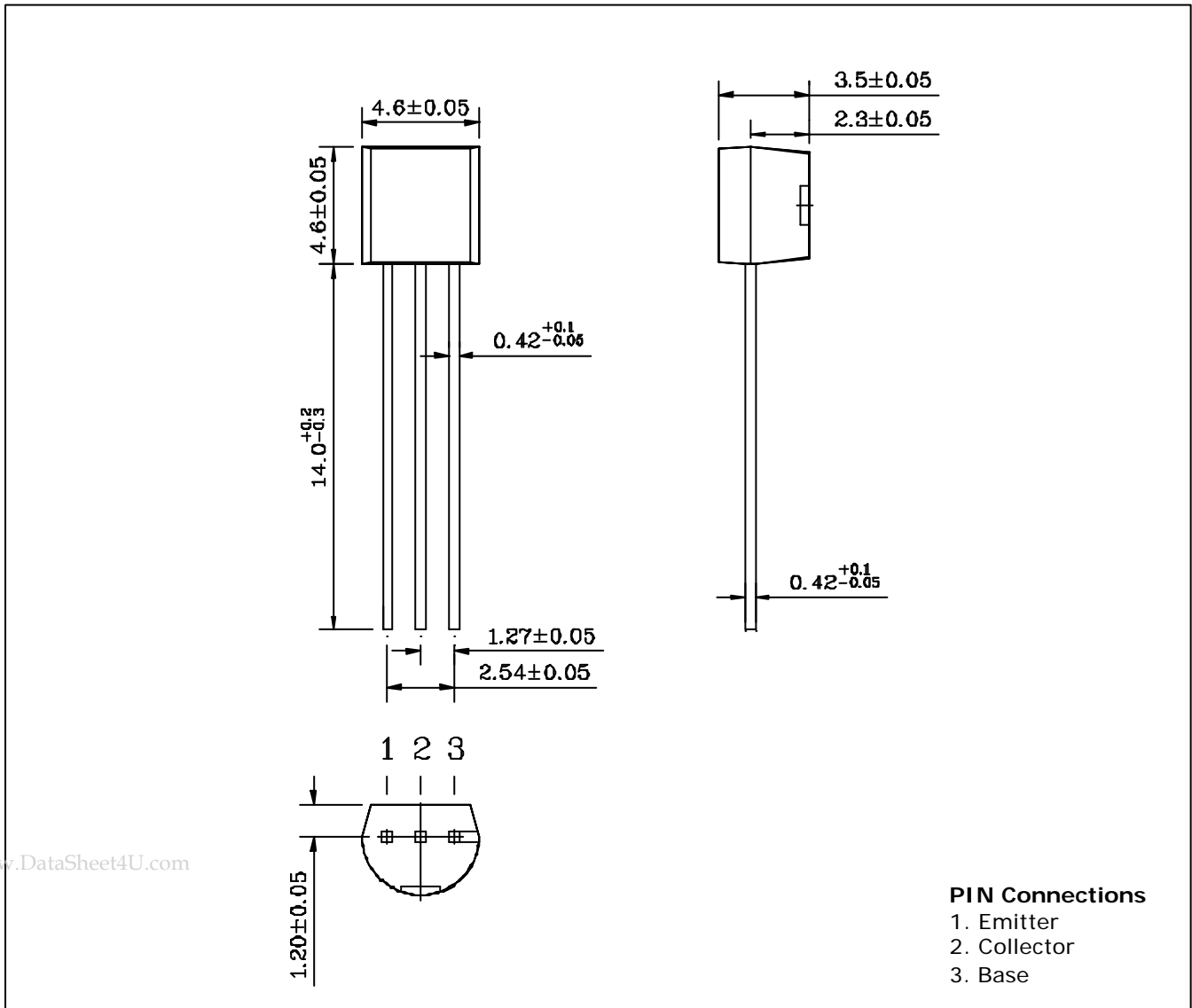

Absolute maximum ratings

(Ta=25° C)

Characteristic	Symbol	Ratings	Unit
Collector-Base voltage	V_{CBO}	15	V
Collector-Emitter voltage	V_{CEO}	12	V
Emitter-Base voltage	V_{EBO}	5	V
Collector current	I_C	300	mA
Collector dissipation	P_C	625	mW
Junction temperature	T_J	150	°C
Storage temperature	T_{stg}	-55 ~ 150	°C

Electrical Characteristics

(Ta=25° C)

Characteristic	Symbol	Test Condition	Min.	Typ.	Max.	Unit
Collector-Base breakdown voltage	BV_{CBO}	$I_C=50\mu A, I_E=0$	15	-	-	V
Collector-Emitter breakdown voltage	BV_{CEO}	$I_C=1mA, I_B=0$	12	-	-	V
Emitter-Base breakdown voltage	BV_{EBO}	$I_E=50\mu A, I_C=0$	5	-	-	V
Collector cut-off current	I_{CBO}	$V_{CB}=12V, I_E=0$	-	-	0.1	μA
Emitter cut-off current	I_{EBO}	$V_{EB}=5V, I_C=0$	-	-	0.1	μA
DC current gain	h_{FE1}	$V_{CE}=1V, I_C=100mA$	200	-	450	-
	h_{FE2}	$V_{CE}=1V, I_C=300mA$	70	-	-	-
Collector-Emitter saturation voltage	$V_{CE(sat1)}$	$I_C=100mA, I_B=10mA$	-	-	0.2	V
	$V_{CE(sat2)}$	$I_C=300mA, I_B=30mA$	-	-	0.5	V
Base-Emitter saturation voltage	$V_{BE(sat1)}$	$I_C=100mA, I_B=10mA$	-	-	1.2	V
	$V_{BE(sat2)}$	$I_C=300mA, I_B=30mA$	-	-	1.7	V
Transition frequency	f_T	$V_{CE}=5V, I_C=10mA$	-	300	-	MHz
Collector output capacitance	C_{ob}	$V_{CB}=10V, I_E=0, f=1MHz$	-	3	-	PF

Electrical Characteristic Curves

Fig. 1 $P_C - T_a$

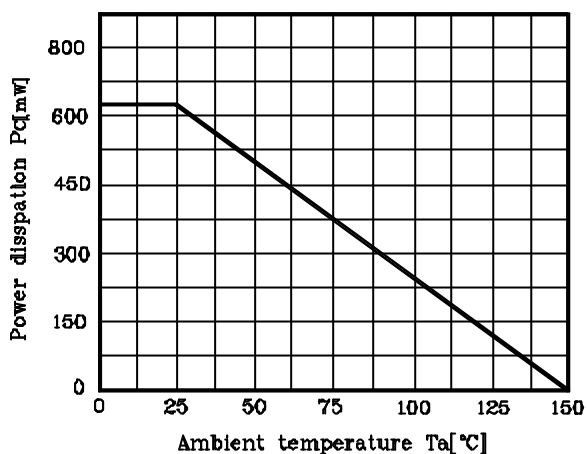

Fig. 2 $I_C - V_{BE}$

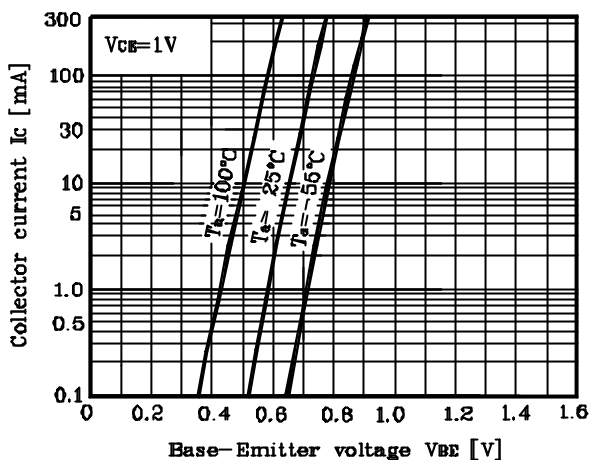

Fig. 3 $h_{FE} - I_C$

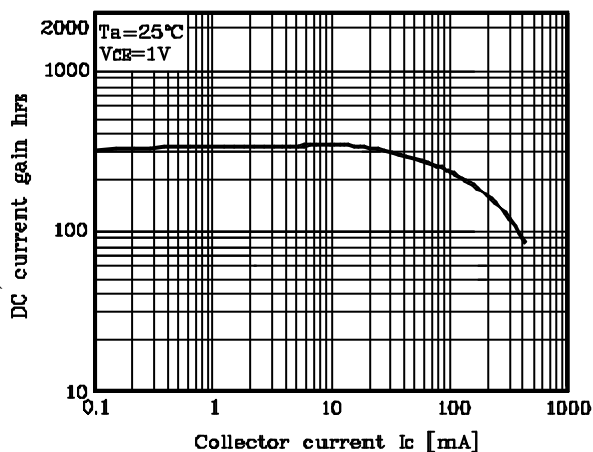

Fig. 4 $I_C - V_{CE}$

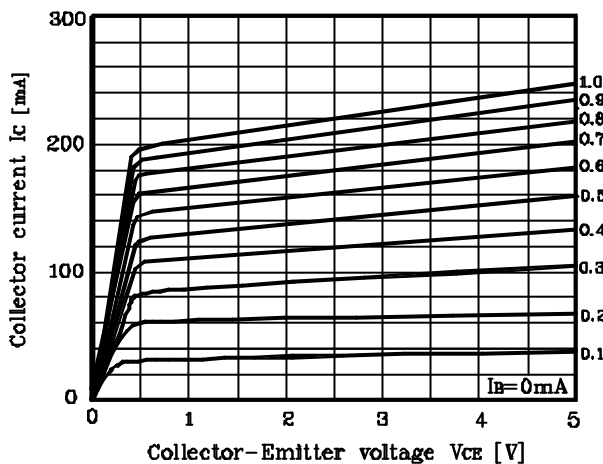

Fig. 5 $V_{CE(sat)} - I_C$

