

## N-Channel Depletion-Mode Vertical DMOS FET

### Features

- ▶ High input impedance
- ▶ Low input capacitance
- ▶ Fast switching speeds
- ▶ Low ON-resistance
- ▶ Free from secondary breakdown
- ▶ Low input and output leakages

### Applications

- ▶ Normally-on switches
- ▶ Battery operated systems
- ▶ Converters
- ▶ Linear amplifiers
- ▶ Constant current sources
- ▶ Telecom

### General Description

The Supertex DN1509 is suitable for high voltage transient protection for LDO in automobile applications during “load dump” conditions.

This low threshold, depletion-mode (normally-on) transistor utilizes an advanced vertical DMOS structure and Supertex’s well-proven silicon-gate manufacturing process. This combination produces a device with the power handling capabilities of bipolar transistors and with the high input impedance and positive temperature coefficient inherent in MOS devices. Characteristic of all MOS structures, this device is free from thermal runaway and thermally-induced secondary breakdown.

Supertex’s vertical DMOS FETs are ideally suited to a wide range of switching and amplifying applications where very low threshold voltage, high breakdown voltage, high input impedance, low input capacitance, and fast switching speeds are desired.

### Ordering Information

Device	Package Option	$BV_{DSX}/BV_{DGX}$	$R_{DS(ON)} (max)$	$I_{DSS} (typ)$
	TO-243AA (SOT-89)			
DN1509	DN1509N8-G	90V	6.0Ω	540mA

Product marking for TO-243AA:  
DN5A\*  
 where \* = 2-week alpha date code

-G indicates package is RoHS compliant ('Green')



### Absolute Maximum Ratings

Parameter	Value
Drain to source voltage	$BV_{DSX}$
Drain to gate voltage	$BV_{DGX}$
Gate to source voltage	±20V
Operating and storage temperature	-55°C to +150°C
Soldering temperature <sup>1</sup>	+300°C

Absolute Maximum Ratings are those values beyond which damage to the device may occur. Functional operation under these conditions is not implied. Continuous operation of the device at the absolute rating level may affect device reliability. All voltages are referenced to device ground.

**Note 1.** Distance of 1.6mm from case for 10 seconds.

### Pin Configuration

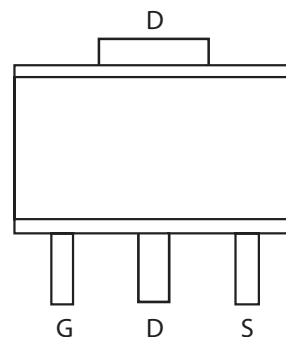

**TO-243AA (SOT-89)**  
(Top View)

**Electrical Characteristics** ( $T_A=25^\circ\text{C}$  unless otherwise specified)

Symbol	Parameter	Min	Typ	Max	Units	Conditions
$BV_{DSX}$	Drain-to-source breakdown voltage	90	-	-	V	$V_{GS} = -5V, I_D = 1.0\mu A$
$V_{GS(OFF)}$	Gate-to-source OFF voltage	-1.8	-	-3.5	V	$I_D = 10\mu A$
$\Delta V_{GS(OFF)}$	$V_{GS(OFF)}$ change with temperature	-	-	4.5	mV/°C	$V_{DS} = 15V, I_D = 10\mu A$
$I_{GSS}$	Gate body leakage	-	-	100	nA	$V_{GS} = \pm 20V, V_{DS} = 0V$
$I_{D(OFF)}$	Drain-to-source leakage current	-	-	1.0	$\mu A$	$V_{DS} = \text{Max rating}, V_{GS} = -5.0V$
		-	-	1.0	mA	$V_{DS} = 0.8 \text{ Max Rating}, V_{GS} = -5.0V, T_A = 125^\circ\text{C}$
$I_{DSS}$	Saturated drain-to-source current	300	540	-	mA	$V_{GS} = 0V, V_{DS} = 25V$
$R_{DS(ON)}$	Static drain-to-source ON-state resistance	-	3.2	6.0	$\Omega$	$V_{GS} = 0V, I_D = 200mA$
$\Delta R_{DS(ON)}$	Change in $R_{DS(ON)}$ with temperature	-	-	1.1	%/°C	$V_{GS} = 0V, I_D = 200mA$
$G_{FS}$	Forward transconductance	200	-	-	mmho	$V_{DS} = 10V, I_D = 200mA$
$C_{ISS}$	Input capacitance	-	70	150	pF	$V_{GS} = -10V, V_{DS} = 25V, f = 1MHz$
$C_{OSS}$	Common source output capacitance	-	20	40		
$C_{RSS}$	Reverse transfer capacitance	-	6.0	15		
$t_{d(ON)}$	Turn-ON delay time	-	12	30	ns	$V_{DD} = 25V, I_D = 100mA, R_{GEN} = 25\Omega$
$t_r$	Rise time	-	16	45		
$t_{d(OFF)}$	Turn-OFF delay time	-	15	45		
$t_f$	Fall time	-	25	60		
$V_{SD}$	Diode forward voltage drop	-	-	1.8	V	$V_{GS} = 0V, I_{SD} = 500mA$
$t_{rr}$	Reverse recovery time	-	400	-	ns	$V_{GS} = 0V, I_{SD} = 500mA$

**Notes:**

1. All D.C. parameters 100% tested at  $25^\circ\text{C}$  unless otherwise stated. (Pulse test:  $300\mu s$  pulse, 2% duty cycle.)
2. All A.C. parameters sample tested.

**Thermal Characteristics**

Package	$I_D$ (continuous) <sup>†</sup>	$I_D$ (pulsed)	Power Dissipation @ $T_A = 25^\circ\text{C}$	$\theta_{JC}$ (°C/W)	$\theta_{JA}$ (°C/W)	$I_{DR}$ <sup>‡</sup>	$I_{DRM}$
TO-243AA	360mA	500mA	1.6W <sup>‡</sup>	15	78 <sup>‡</sup>	360mA	500mA

**Notes:**

- <sup>†</sup>  $I_D$  (continuous) is limited by max rated  $T_J$  of  $150^\circ\text{C}$ .
- <sup>‡</sup> Mounted on FR4 board, 25mm x 25mm x 1.57mm.

**Switching Waveforms and Test Circuit**

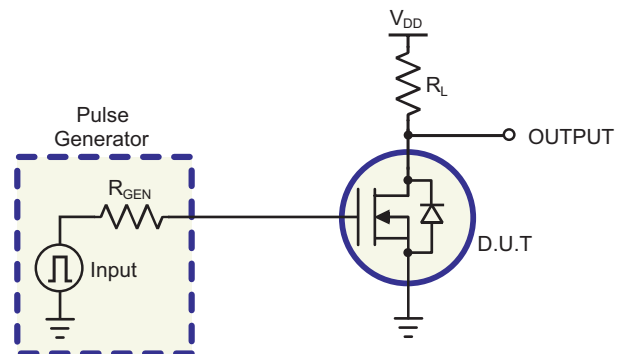
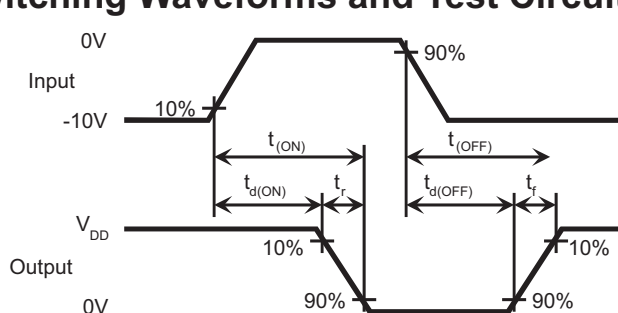

TO-243AA (SOT-89) Package Outline (N8)

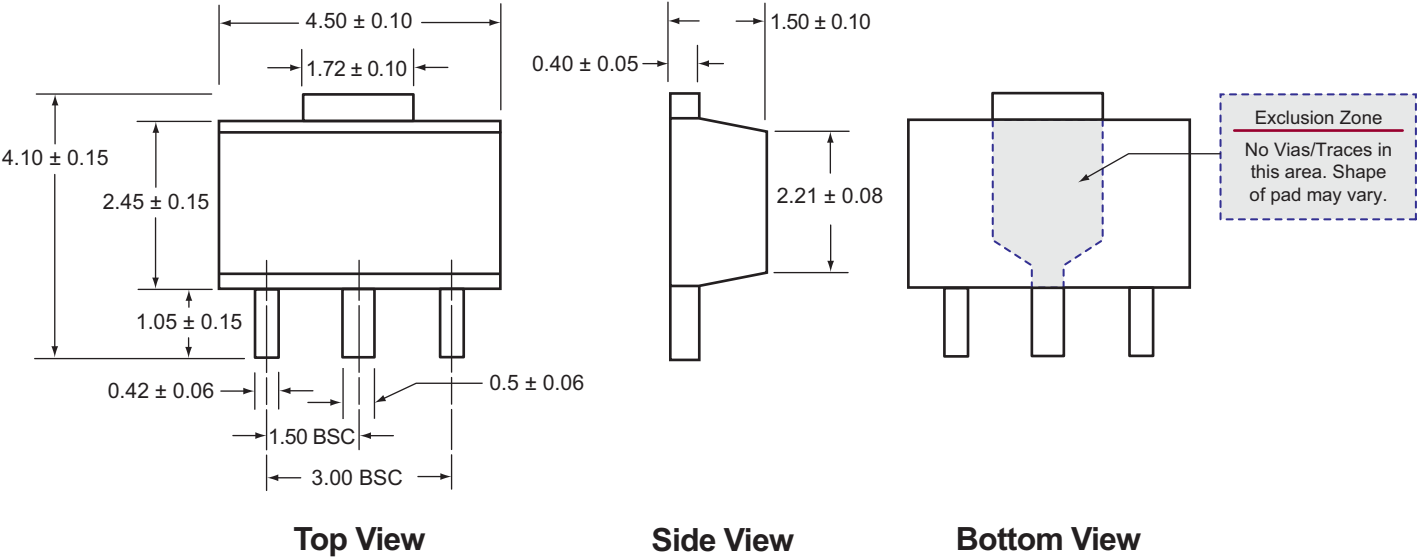

- Notes:**
1. All dimensions are in millimeters; all angles in degrees.

(The package drawing(s) in this data sheet may not reflect the most current specifications. For the latest package outline information go to <http://www.supertex.com/packaging.html>.)

**Supertex inc.** does not recommend the use of its products in life support applications, and will not knowingly sell its products for use in such applications, unless it receives an adequate "product liability indemnification insurance agreement". **Supertex** does not assume responsibility for use of devices described and limits its liability to the replacement of the devices determined defective due to workmanship. No responsibility is assumed for possible omissions or inaccuracies. Circuitry and specifications are subject to change without notice. For the latest product specifications, refer to the **Supertex** website: <http://www.supertex.com>.