

FEATURES

- 1010 - 1110 MHz
- Constant Insertion Loss
- 48 nSec Switching Speed
- TTL Control
- 38 Pin DIP



MODEL NO.
DP0891

GaAs 5 Section Phase Shifter

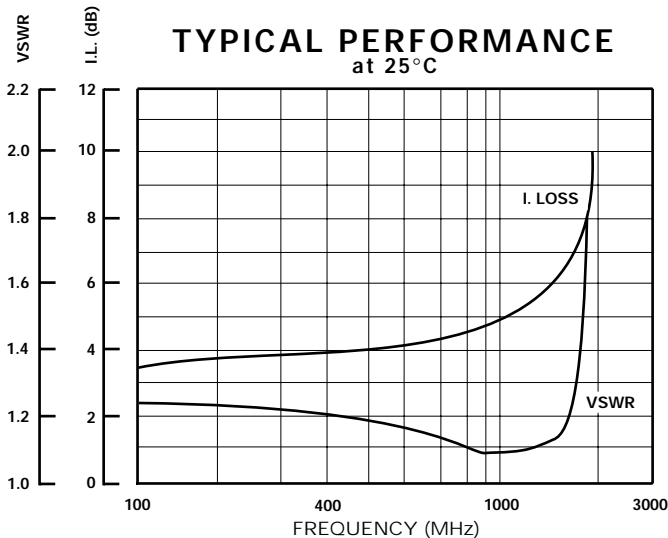
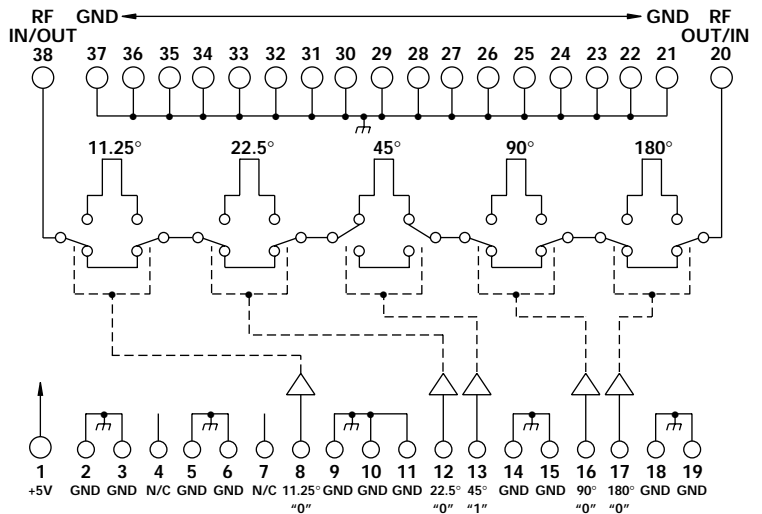
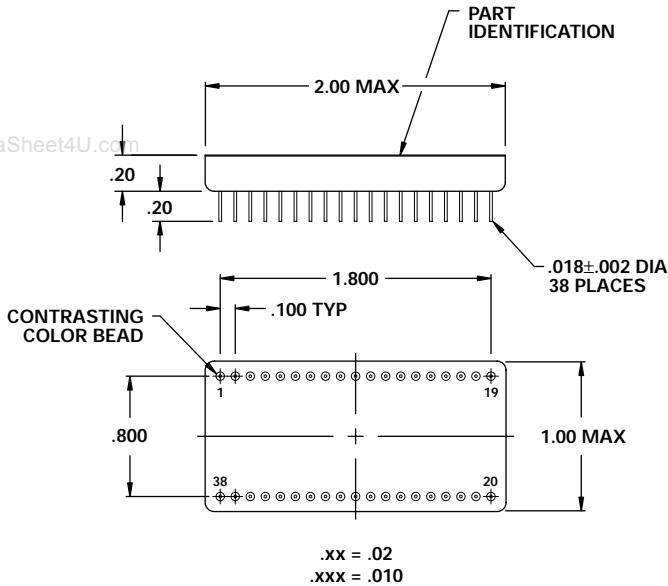

GUARANTEED PERFORMANCE

Parameter	Min	Typ	Max	Units	Conditions
Operating Frequency	1010		1110	MHz	
DC Current		1.2	10	mA	At +5 VDC Supply
Control Type		TTL			5 Line Logic "0" = Thru Logic "1" = Phase Shift
Control Current	High Low	1 1	±20 ±20	µA	V _{IH} = +3.0 V V _{IL} = +0.5 V
Insertion Loss	Stability	5.3 ±0.2	7.5 ±0.5	dB	For All Phase Shifters
Phase Shift	LSB Range Accuracy	0	11.25 348.75 ±5 ±10	DEG DEG DEG DEG	11.25, 22.5, 45, 90, 180 Any 1 Bit Any Combination
VSWR		1.15/1	1.3/1		
Impedance		50		OHMS	
Switching Speed		48	100	nSec	50% TTL to 90% / 10% RF
Transition (Rise/Fall) Time		25		nSec	90% / 10% or 10% / 90% RF
Switching (Video) Transients		180		mV	Peak Value
Intercept Points	2nd 3rd	+80 +50		dBm dBm	
RF Power	Operate No Damage	+26 +27	+24 +27	dBm dBm	0.1 dB Compression
Operating Temperature		-40	+25 +70	°C	TA