

Specification

DP**DOPOINT****170****Size****H****Pixel**

A:640*480

B:800*480

C:800*600

D:1024*600

E:1024*768

F:1280*768

G:1280*800

H:1280*1024

HD:1366*768

J:1600*1200

K:1920*1200

FHD:1920*1080

T**Mode**

T: TN

I: IPS

| Product Order Number | Description |
|----------------------|---|
| DP170HT-XXXX | <ul style="list-style-type: none"> • TN Normally White • -0°C to +50°C Operating Temperature • Viewing Angle L/R/U/D - 85/85/80/80 • Luminance – 1500 cd/m² • Contrast Ratio – 1000:1 |
| DP170HT-TXXX | Resistive + Capacitive Touch by Optical Bonding |
| DP170HT-HXXX | Extended temp (Add Heater by Optical Bonding) -40°C to +80°C Operating Temperature |
| DP170HT-EXXX | Integrated Front Optical EMI Filter by Optical Bonding |
| DP170HT-ARAG | Anti-Reflective + Anti-Glare Surface Treatment |
| DP170HT-NVIS | Integrated NVIS Optical Filter |

Sunlight Readable LCDs With Optical Bonding + Touch Integration

Specification

1. Handling Precautions

- 1) Since front polarizer is easily damaged, pay attention not to scratch it.
- 2) Be sure to turn off power supply when inserting or disconnecting from input connector.
- 3) Wipe off water drop immediately. Long contact with water may cause discoloration or spots.
- 4) When the panel surface is soiled, wipe it with absorbent cotton or other soft cloth.
- 5) Since the panel is made of glass, it may break or crack if dropped or bumped on hard surface.
- 6) Since CMOS LSI is used in this module, take care of static electricity and insure human earth when handling.
- 7) Do not open or modify the Module Assembly.
- 8) Do not press the reflector sheet at the back of the module to any directions.
- 9) In case if a Module has to be put back into the packing container slot after once it was taken out from the container, do not press the center of the LED light bar edge. Instead, press at the far ends of the LED light bar edge softly. Otherwise the TFT Module may be damaged.
- 10) At the insertion or removal of the Signal Interface Connector, be sure not to rotate nor tilt the Interface Connector of the TFT Module.
- 11) After installation of the TFT Module into an enclosure, do not twist nor bend the TFT Module even momentary. At designing the enclosure, it should be taken into consideration that no bending/twisting forces are applied to the TFT Module from outside. Otherwise the TFT Module may be damaged.
- 12) Small amount of materials having no flammability grade is used in the LCD module. The LCD module should be supplied by power complied with requirements of Limited Power Source (IEC60950 or UL1950), or be applied exemption.

Sunlight Readable LCDs With Optical Bonding + Touch Integration

Specification

2. General Description

This specification applies to the 17 inch Color TFT-LCD Module DP170HT.

The display supports the SXGA (1280(H) x 1024(V)) screen format and 16.7M colors (RGB 6-bits+Hi-FRC data).All

input signals are 2 Channel LVDS interface compatible.

This module embeds an LED driver on it.

2.1 Display Characteristics

The following items are characteristics summary on the table under 25 condition:

| Items | Unit | Specifications |
|---|----------------------|--|
| Screen Diagonal | [mm] | 432 (17.0") |
| Active Area | [mm] | 337.920(H) × 270.336(V) |
| Pixels H x V | | 1280 × 3(RGB) × 1024 |
| Pixel Pitch | [mm] | 0.264(per one triad) × 0.264 |
| Pixel Arrangement | | R.G.B. Vertical Stripe |
| Display Mode | | Normally White |
| White Luminance | [cd/m ²] | 1500(Typ) |
| Contrast Ratio | | 1000 : 1 (Typ) |
| Optical ResponseTime | [msec] | 5 (Typ) |
| Nominal Input Voltage VDD | [Volt] | +5.0 (Typ) |
| Power Consumption (VDD line + LED line) | [Watt] | 13 W |
| Weight | [Grams] | 1300g(Typ) |
| Physical Size (H x V x D) | [mm] | 358.5(H) x 296.5(V) Typ. x 18.0(D) Max |
| Electrical Interface | | Dual Channel LVDS |
| Surface Treatment | | Anti-glare type, Hardness 3H |
| Support Color | | 16.7M colors (RGB 6-bits +Hi-FRC data) |
| Temperature Range Operating Storage (Non-Operating) | [C] [°C] | 0 to +50 -20 to +60 |
| RoHS Compliance | | RoHS Compliance |

Sunlight Readable LCDs With Optical Bonding + Touch Integration

Specification

2.2 Optical Characteristics

The optical characteristics are measured under stable conditions at 25℃ (Room Temperature):

| Item | Unit | Conditions | Min. | Typ. | Max. | Note |
|---|----------------------|--------------------------------------|-------|-------|-------|------|
| Viewing Angle | [degree] | Horizontal (Right) (Left) CR = 10 | 140 | 170 | - | 1 |
| | | Vertical (Up) (Down) CR = 10 | 140 | 160 | - | |
| Luminance Uniformity | [%] | 9 Points | 75 | 80 | - | 2, 3 |
| Optical Response Time | [msec] | Rising | - | 3.5 | 6 | 4, 6 |
| | | Falling | - | 1.5 | 3 | |
| | | Rising + Falling | - | 5 | 9 | |
| Color / Chromaticity Coordinates (CIE 1931) | | Red x | 0.609 | 0.639 | 0.669 | 4 |
| | | Red y | 0.302 | 0.332 | 0.362 | |
| | | Green x | 0.304 | 0.334 | 0.364 | |
| | | Green y | 0.591 | 0.621 | 0.651 | |
| | | Blue x | 0.125 | 0.155 | 0.185 | |
| | | Blue y | 0.019 | 0.049 | 0.079 | |
| | | White x | 0.283 | 0.313 | 0.343 | |
| White y | 0.299 | 0.329 | 0.359 | | | |
| White Luminance (At LED= 60mA) | [cd/m ²] | | 1400 | 1500 | - | 4 |
| Contrast Ratio | | | 600 | 1000 | - | 4 |
| Cross Talk (At 75Hz) | [%] | | - | - | 1.5 | 5 |
| Flicker | [dB] | | - | - | -20 | 7 |
| Color Gamut | [%] | | | 72 | | |

Optical Equipment: BM-5A, BM-7, PR880, or equivalent

Sunlight Readable LCDs With Optical Bonding + Touch Integration

Specification

Note 1: Definition of viewing angle

Viewing angle is the measurement of contrast ratio ≥ 10 , at the screen center, over a 180° horizontal and 180° vertical range (off-normal viewing angles). The 180° viewing angle range is broken down as follows; 90° (θ) horizontal left and right and 90° (ϕ) vertical, high (up) and low (down). The measurement direction is typically perpendicular to the display surface with the screen rotated about its center to develop the desired measurement viewing angle.

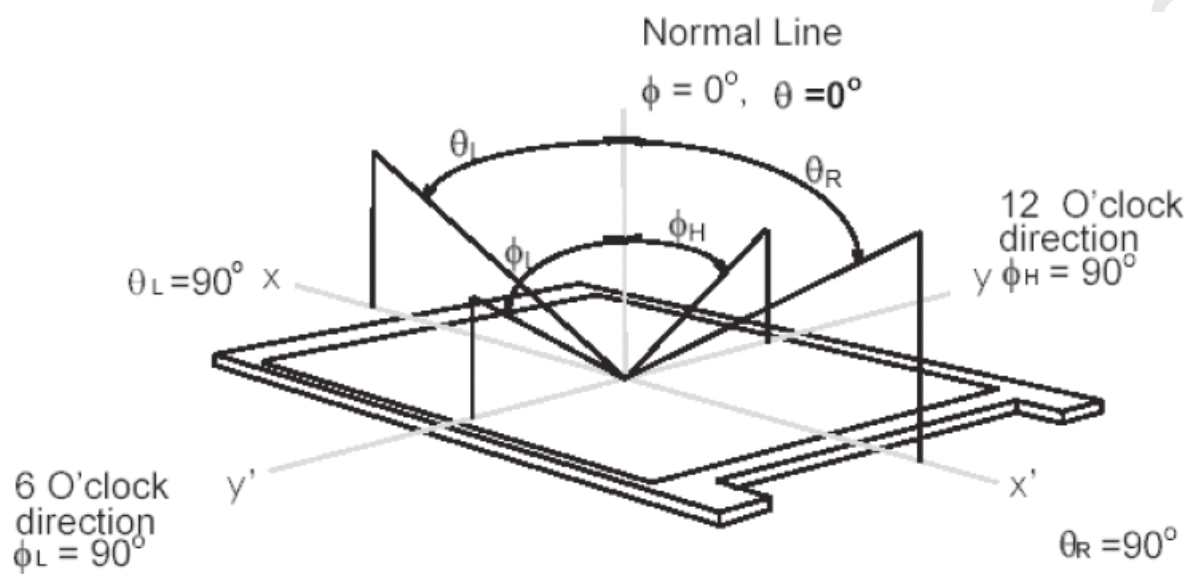

Note 2: 9 points position

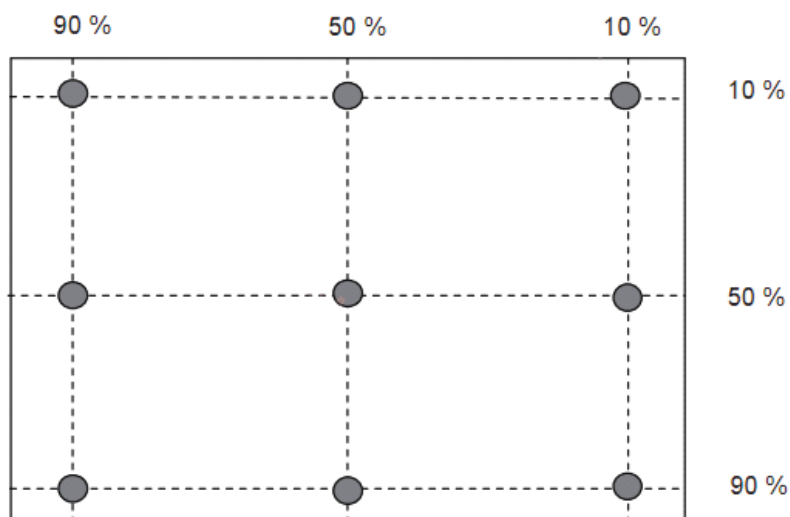

Note 3: The luminance uniformity of 9 points is defined by dividing the maximum luminance values by the minimum test point luminance

$$\delta_{w9} = \frac{\text{Minimum Luminance of 9 points}}{\text{Maximum Luminance of 9 points}}$$

Sunlight Readable LCDs With Optical Bonding + Touch Integration

Specification

Note 4: Measurement method

The LCD module should be stabilized at given temperature for 30 minutes to avoid abrupt temperature change during measuring. In order to stabilize the luminance, the measurement should be executed after lighting Backlight for 30 minutes in a stable, windless and dark room.

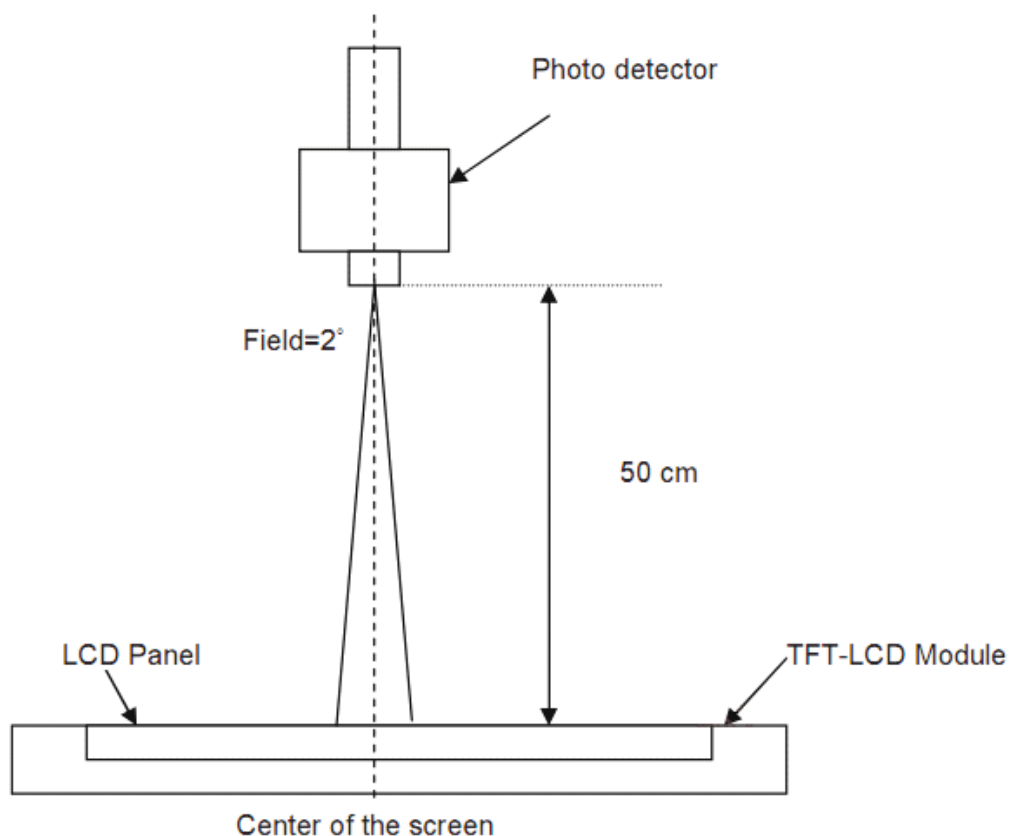

Note 5: Definition of Cross Talk (CT)

$$CT = | YB - YA | / YA \times 100 (\%)$$

Where

YA = Luminance of measured location without gray level 0 pattern (cd/m²)

YB = Luminance of measured location with gray level 0 pattern (cd/m²)

Sunlight Readable LCDs With Optical Bonding + Touch Integration



DP170HT

Specification

Note 6: Definition of response time:

The output signals of photo detector are measured when the input signals are changed from “Full Black” to “Full White” (rising time), and from “Full White” to “Full Black” (falling time), respectively. The response time is interval between the 10% and 90% of amplitudes. Please refer to the figure as below.

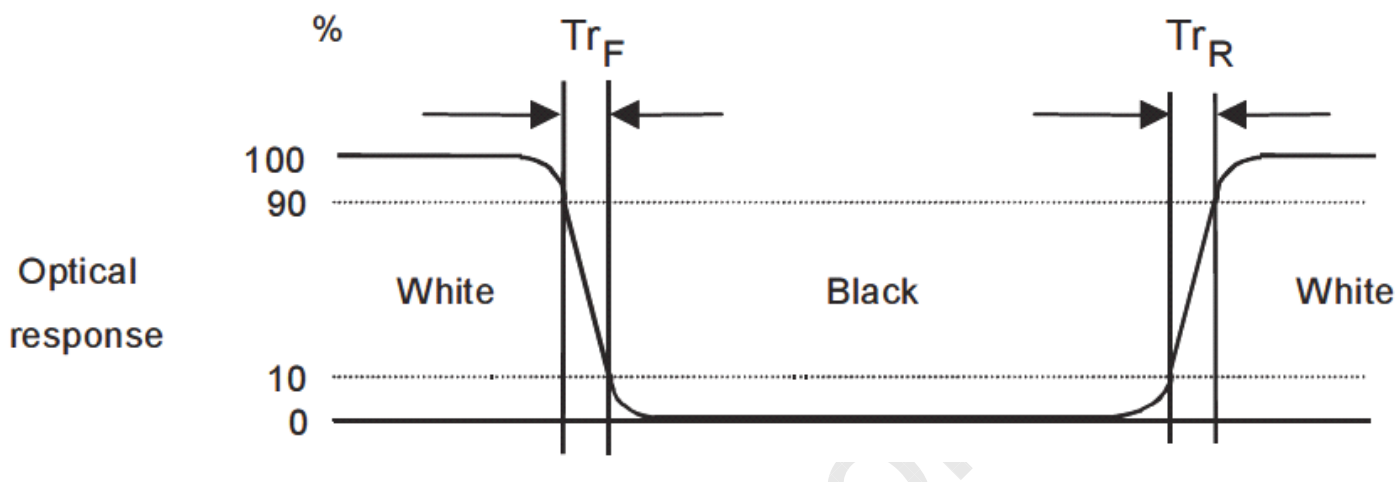

Note 7: Subchecker Pattern

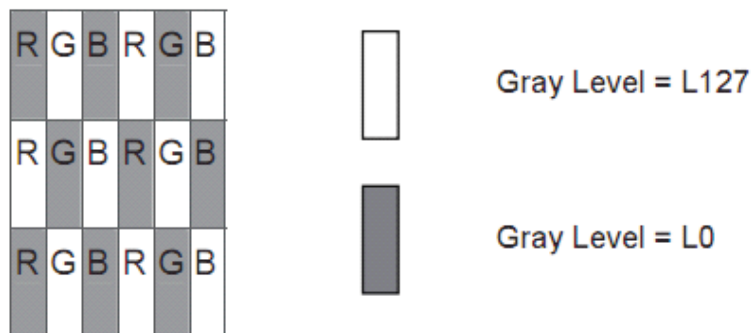

Method: Record dBV & DC value with (WESTAR)TRD-100

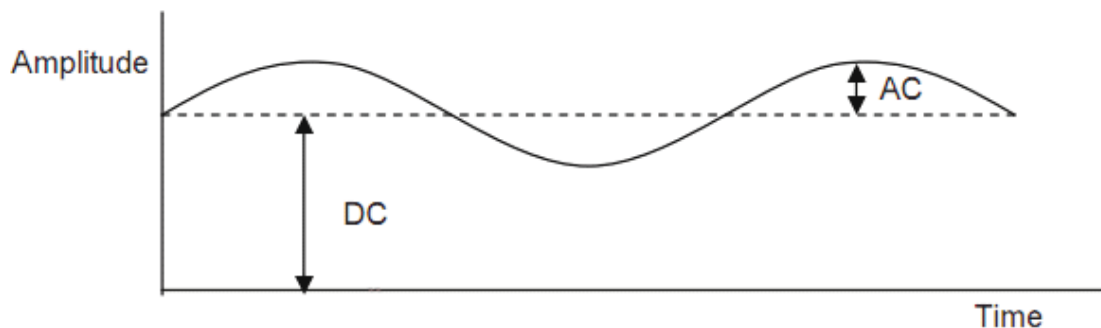

$$\text{Flicker (dB)} = 20 \log \frac{\text{AC Level(at 30 Hz)}}{\text{DC Level}}$$

Sunlight Readable LCDs With Optical Bonding + Touch Integration

Specification

3. Functional Block Diagram

The following diagram shows the functional block of the 17.0 inches Color TFT-LCD Module:

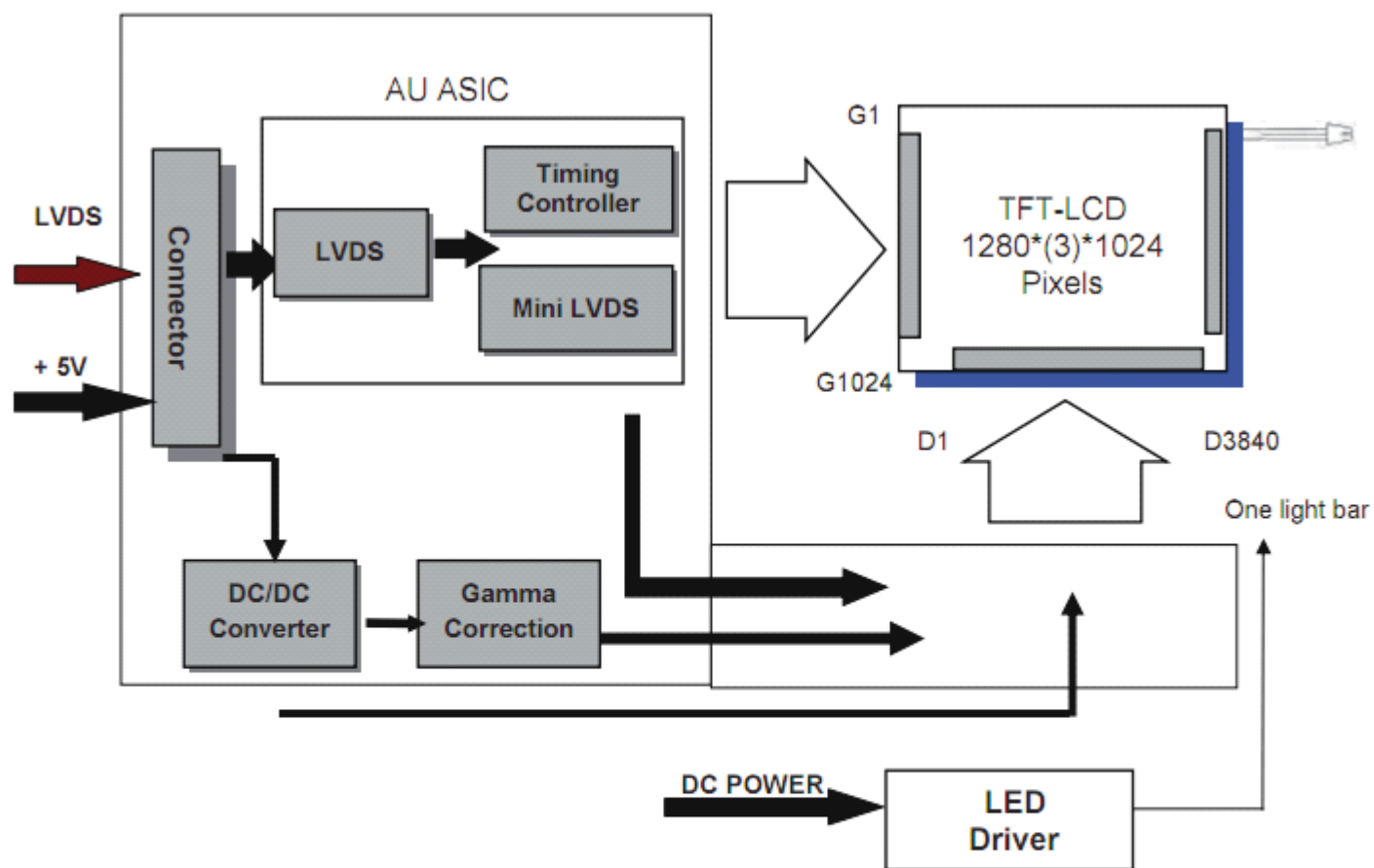
**PCBA Connector:**

JAE FI-XB30SSL-HF15
Or Compatible

LED Driver Connector:

Entery 3806K-F06Y-03R
Or Compatible

Sunlight Readable LCDs With Optical Bonding + Touch Integration

Specification

4. Absolute Maximum Ratings

Absolute maximum ratings of the module is as following:

4.1 TFT LCD Module

| Item | Symbol | Min | Max | Unit | Conditions |
|-------------------------|--------|------|-----|--------|------------|
| Logic/LCD Drive Voltage | VIN | -0.3 | 6 | [Volt] | Note 1,2 |

4.2 Backlight Unit

| Item | Symbol | Min | Max | Unit | Conditions |
|---------------------|----------------|-----|-----|------|------------|
| LED Forward Current | I _F | - | | [mA] | Note 1,2 |

4.3 Absolute Ratings of Environment

| Item | Symbol | Min | Max | Unit | Conditions |
|-----------------------|--------|-----|-----|-------|------------|
| Operating Temperature | TOP | 0 | +50 | [°C] | Note 3 |
| Operation Humidity | HOP | 5 | 90 | [%RH] | |
| Storage Temperature | TST | -20 | +60 | [°C] | |
| Storage Humidity | HST | 5 | 90 | [%RH] | |

Note 1: With in Ta (25□)

Note 2: Permanent damage to the device may occur if exceed maximum values

Note 3: For quality performance, please refer to AUO IIS (Incoming Inspection Standard).

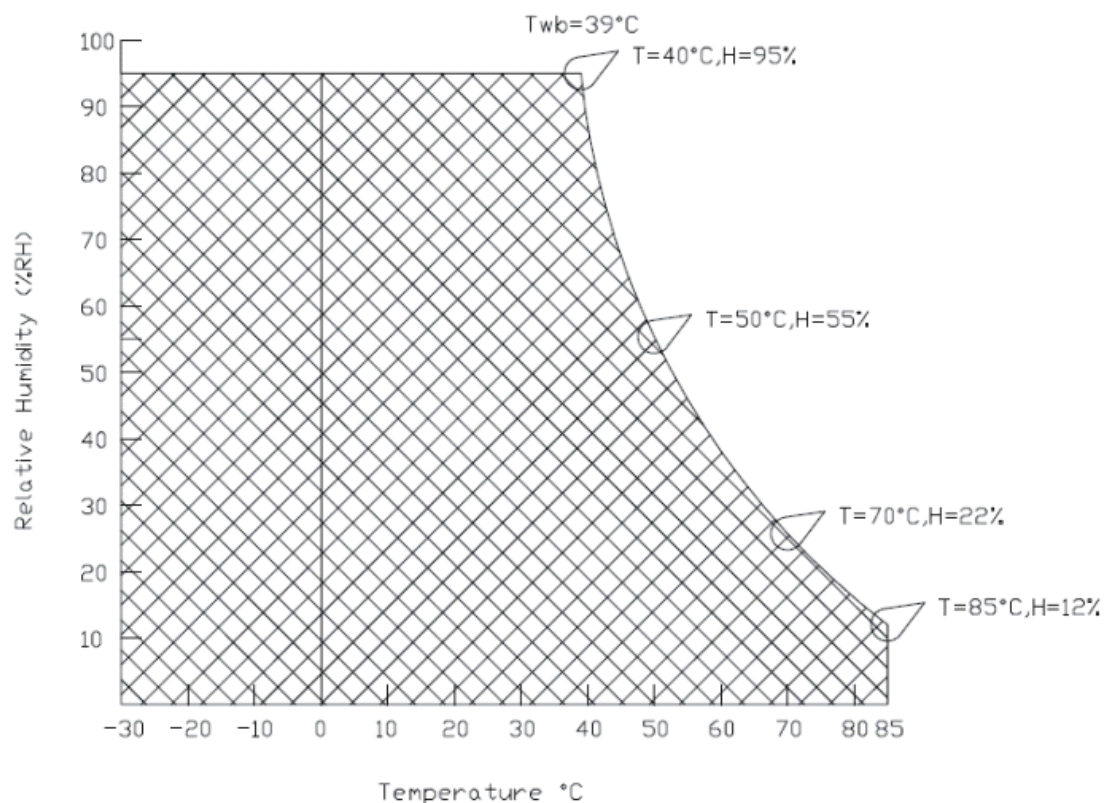

Sunlight Readable LCDs With Optical Bonding + Touch Integration

Specification

5. Electrical characteristics

5.1 TFT LCD Module

5.1.1 Power Specification

Input power specifications are as follows:

| Symble | Parameter | Min. | Typ. | Max. | Unit | Condition |
|--------|--|------|------|------|-------------|-------------------------------------|
| VCC | Logic/LCD Drive Voltage | 4.5 | 5.0 | 5.5 | [Volt] | ±10% |
| ICC | Input Current | - | 0.59 | 0.71 | [A] | Vin=5V , All Black Pattern, at 75Hz |
| PCC | VCCPower | - | 2.95 | 3.54 | [Watt] | Vin=5V , All Black Pattern, at 75Hz |
| VCCrp | Allowable Logic/LCD Drive Ripple Voltage | - | - | 500 | [mV] p-p | With panel loading |

5.1.2 Signal Electrical Characteristics

Input signals shall be low or Hi-Z state when Vin is off

It is recommended to refer the specifications of SN75LVDS82DGG (Texas Instruments) in detail.

Each signal characteristics are as follows;

| Symbol | Parameter | Min | Typ | Max | Units | Condition |
|--------|--|------|------|------|-------|---------------------------------|
| VTH | Differential Input High Threshold | - | - | +100 | [mV] | VICM = 1.2V Note |
| VTL | Differential Input Low Threshold | -100 | - | - | [mV] | VICM = 1.2V Note |
| VID | Input Differential Voltage | 100 | 400 | 600 | [mV] | Note |
| VICM | Differential Input Common Mode Voltage | +1.0 | +1.2 | +1.5 | [V] | VTH/VTL = ±100mV Note |

Note: LVDS Signal Waveform

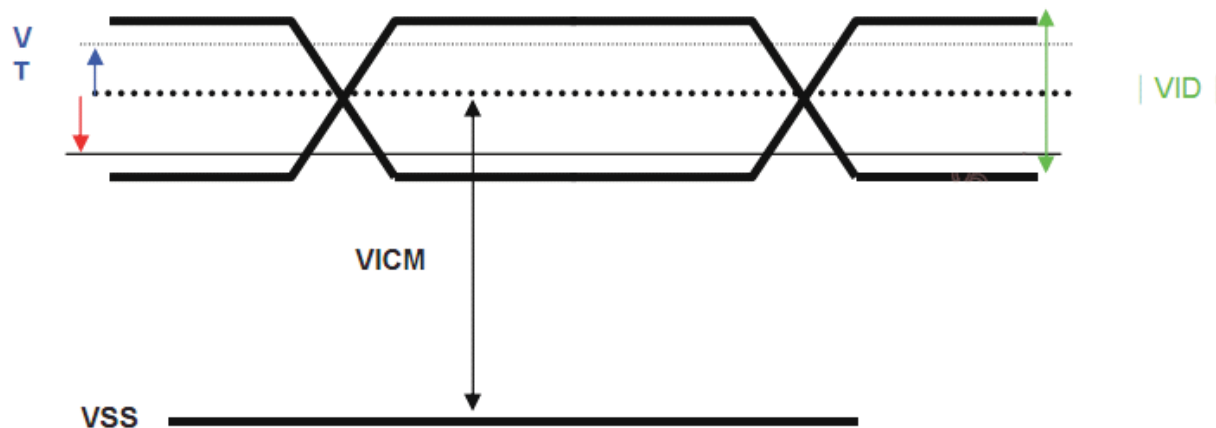

Sunlight Readable LCDs With Optical Bonding + Touch Integration

Specification

5.2 Backlight Unit

Parameter guideline LED

Following characteristics are measured under stable condition at 25°C (Room Temperature)

| Symbol | Parameter | Min. | Typ. | Max. | Unit | Remark |
|------------------|-----------------------|-------|------|------|------|-------------------------------|
| V_{LED} | Input Voltage | 10.8 | 12 | 12.6 | Volt | |
| I_{LED} | Input Current | - | 0.8 | - | A | 100% Dimming |
| P_{LED} | Power Consumption | - | 9.6 | - | Watt | 100% Dimming |
| $I_{INRUSH LED}$ | Inrush Current | - | - | 5.1 | A | V_{LED} rising time ~ 470us |
| F_{PWM} | PWM Dimming Frequency | 200 | - | 20K | Hz | Note 1,2 |
| $V_{PWM DIM}$ | Swing Voltage High | 3.0 | 3.3 | 5.5 | Volt | |
| | Swing Voltage Low | - | - | 0.8 | Volt | |
| D_{PWM} | Dimming Duty Cycle | 10 | - | 100 | % | |
| I_F | LED Forward Current | - | 60 | - | mA | Ta = 25°C |
| $V_{LED ON/OFF}$ | On Control Voltage | 3.0 | 3.3 | 5.5 | Volt | Note 3, 4 |
| | Off Control Voltage | - | - | 0.8 | Volt | |
| Operating Life | | 30000 | - | - | Hrs | Note 5, 6 |

Note 1: PWM dimming function can be operated by PWM signal. PWM duty cycle can adjust white Luminance. (PWM High: ON and PWM Low: OFF)

Note 2: PWM signal can not be floating and pull-down to ground when waiting.

Note 3: Enable (VLED On/Off) must be turned on late than VLED and PWM Signal.

Note 4: Enable (VLED On/Off) must be turned off early than VLED and PWM Signal.

Note 5: If DP170HT module is driven by high current or at high ambient temperature & humidity condition. The

operating life will be reduced.

Note 6: Operating life means brightness goes down to 50% initial brightness. Minimum operating life time is estimated

data.

Sunlight Readable LCDs With Optical Bonding + Touch Integration



DP170HT

Specification

6. Signal Characteristic

6.1 Pixel Format Image

Following figure shows the relationship of the input signals and LCD pixel format.

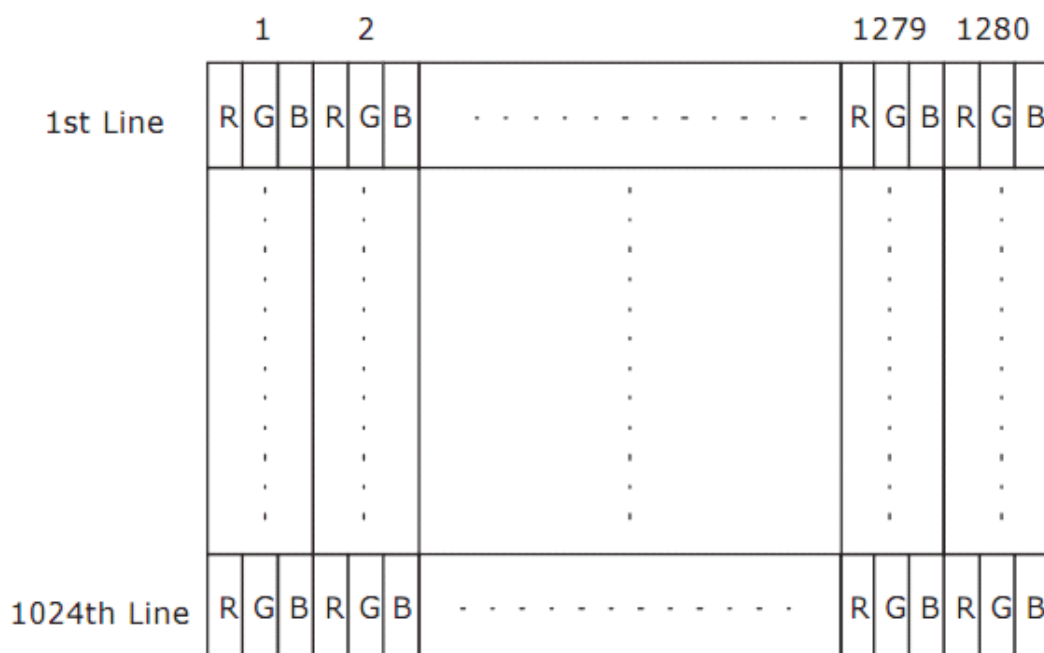

6.2 The Input Data Format

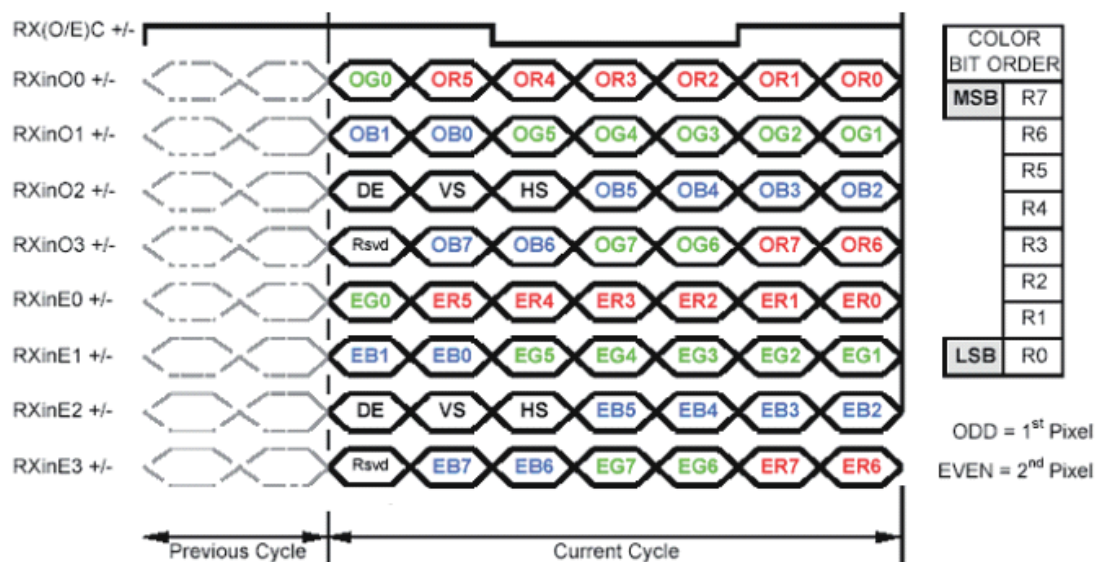

Note1: Normally, DE, VS, HS on EVEN channel are not used.

Note2: Please follow PSWG.

Note3: 8-bit in

Sunlight Readable LCDs With Optical Bonding + Touch Integration

Specification

6.3 Signal Description

The module using a pair of LVDS receiver SN75LVDS82(Texas Instruments) or compatible. LVDS is a differential signal technology for LCD interface and high speed data transfer device. Transmitter shall be SN75LVDS83(negative edge sampling) or compatible. The first LVDS port(RxOxxx) transmits odd pixels while the second LVDS port(RxExxx) transmits even pixels.

| PIN # | SIGNAL NAME | DESCRIPTION |
|-------|-------------|--|
| 1 | RxO0- | Negative LVDS differential data input (Odd data) |
| 2 | RxO0+ | Positive LVDS differential data input (Odd data) |
| 3 | RxO1- | Negative LVDS differential data input (Odd data) |
| 4 | RxO1+ | Positive LVDS differential data input (Odd data) |
| 5 | RxO2- | Negative LVDS differential data input (Odd data, H-Sync,V-Sync,DSPTMG) |
| 6 | RxO2+ | Positive LVDS differential data input (Odd data, H-Sync,V-Sync,DSPTMG) |
| 7 | GND | Power Ground |
| 8 | RxOC- | Negative LVDS differential clock input (Odd clock) |
| 9 | RxOC+ | Positive LVDS differential clock input (Odd clock) |
| 10 | RxO3- | Negative LVDS differential data input (Odd data) |
| 11 | RxO3+ | Positive LVDS differential data input (Odd data) |
| 12 | RxE0- | Negative LVDS differential data input (Even data) |
| 13 | RxE0+ | Positive LVDS differential data input (Even data) |
| 14 | GND | Power Ground |
| 15 | RxE1- | Negative LVDS differential data input (Even data) |
| 16 | RxE1+ | Positive LVDS differential data input (Even data) |
| 17 | GND | Power Ground |
| 18 | RxE2- | Negative LVDS differential data input (Even data) |
| 19 | RxE2+ | Positive LVDS differential data input (Even data) |
| 20 | RxEC- | Negative LVDS differential clock input (Even clock) |
| 21 | RxEC+ | Positive LVDS differential clock input (Even clock) |
| 22 | RxE3- | Negative LVDS differential data input (Even data) |
| 23 | RxE3+ | Positive LVDS differential data input (Even data) |
| 24 | GND | Power Ground |
| 25 | GND | Power Ground (For AUO test Aging+HVS mode) |
| 26 | NC | No contact |
| 27 | GND | Power Ground |
| 28 | VCC | +5.0V Power Supply |
| 29 | VCC | +5.0V Power Supply |
| 30 | VCC | +5.0V Power Supply |

Sunlight Readable LCDs With Optical Bonding + Touch Integration

Specification

Note1: Start from left side

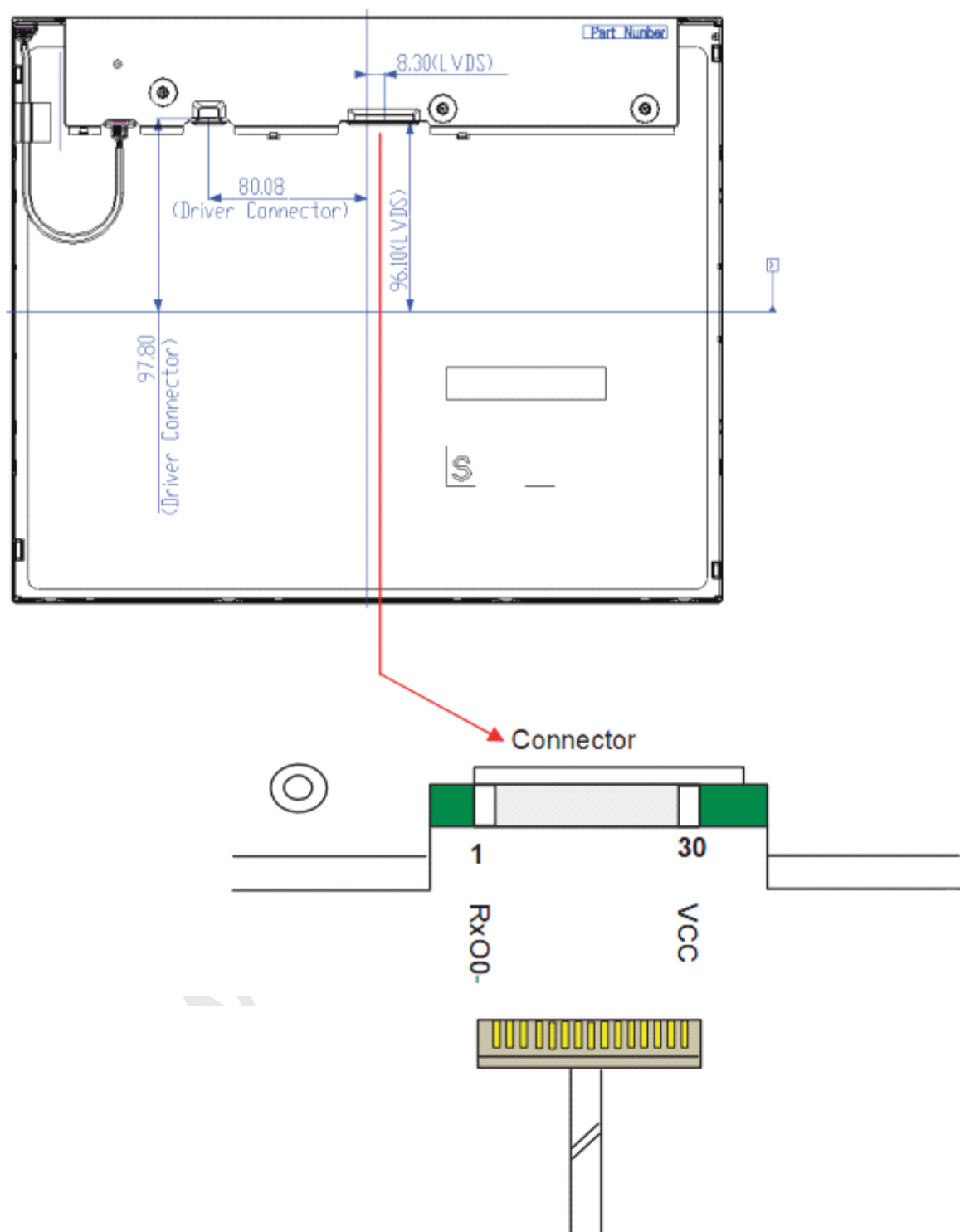

Note2: Input signals of odd and even clock shall be the same timing.

Note3: Please follow PSWG.

Sunlight Readable LCDs With Optical Bonding + Touch Integration

Specification

6.4 Timing Characteristics

6.4.1 Timing Characteristics

Basically, interface timings described here is not actual input timing of LCD module but output timing of SN75LVDS82DGG (Texas Instruments) or equivalent.

| Signal | Item | Symbol | Min | Typ | Max | Unit |
|--------------------|------------|--------------------|-------|-------|------|------|
| Vertical Section | Period | Tv | 1032 | 1066 | 1150 | Th |
| | Active | Tdisp(v) | 1024 | 1024 | 1024 | Th |
| | Blanking | Tbp(v)+Tfp(v)+PWvs | 8 | 42 | 126 | Th |
| Horizontal Section | Period | Th | 780 | 844 | 2048 | Tclk |
| | Active | Tdisp(h) | 640 | 640 | 640 | Tclk |
| | Blanking | Tbp(h)+Tfp(h)+PWhs | 140 | 204 | 1408 | Tclk |
| Clock | Period | Tclk | 14.81 | 18.52 | 25 | ns |
| | Frequency | Freq | 40 | 54 | 67.5 | MHz |
| Frame rate | Frame rate | F | 50 | 60 | 75 | Hz |

Note : DE mode only

Sunlight Readable LCDs With Optical Bonding + Touch Integration

Specification

6.4.2 Timing Diagram

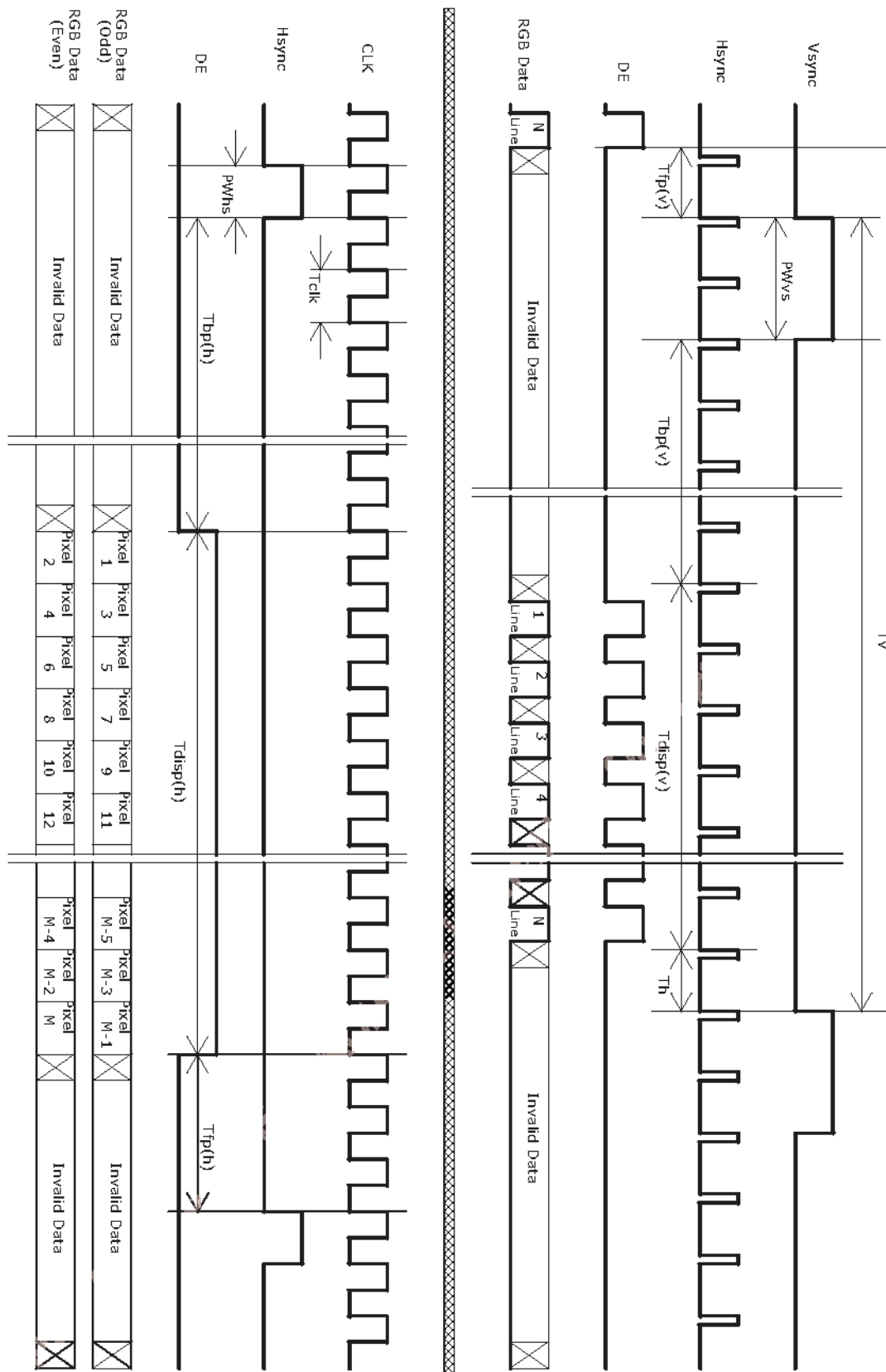

Sunlight Readable LCDs With Optical Bonding + Touch Integration

Specification

6.5 Power ON/OFF Sequence

VDD power and lamp on/off sequence is as follows. Interface signals are also shown in the chart. Signals from any system shall be Hi-Z state or low level when VDD is off.

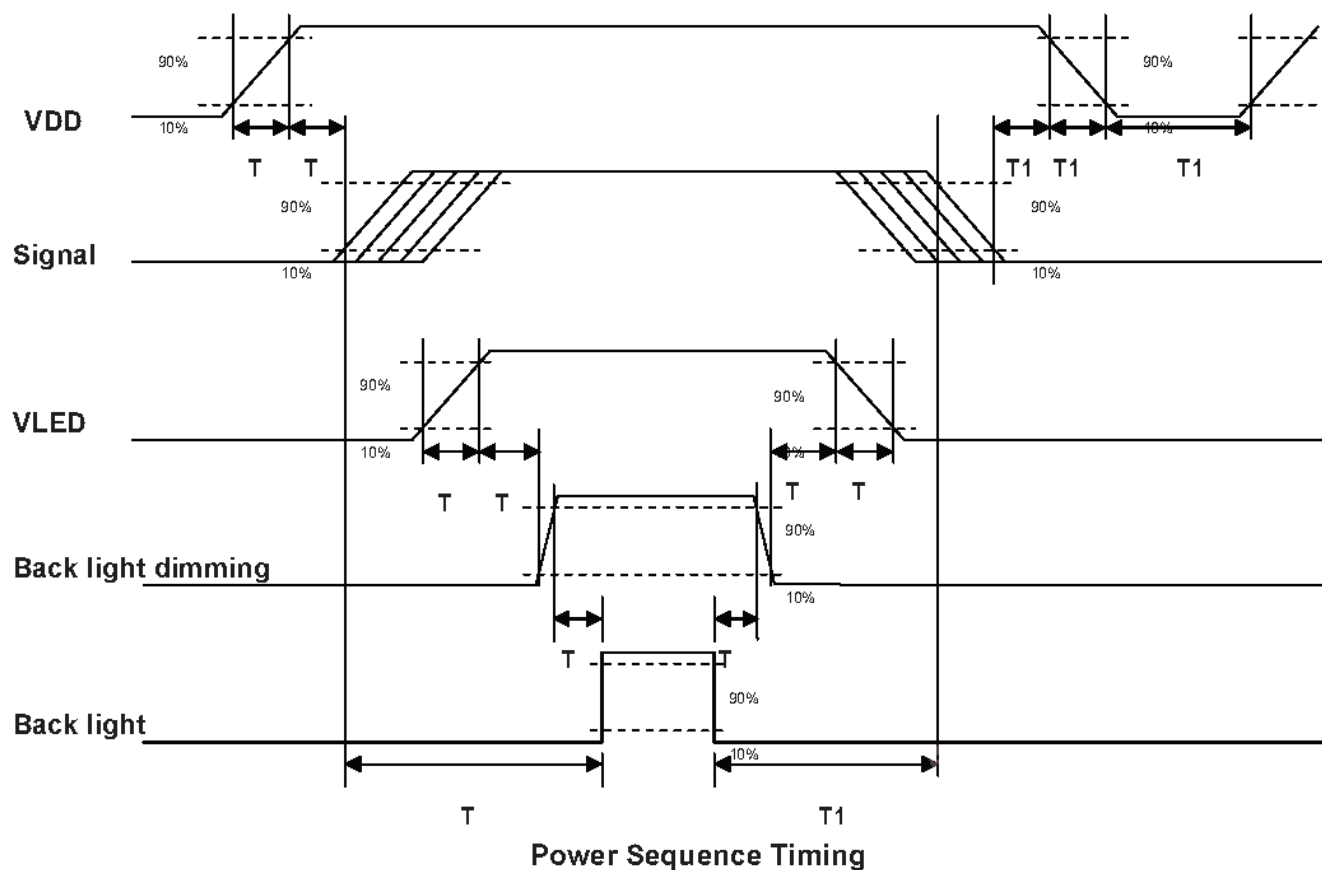

Power Sequence Timing

| Parameter | Value | | | Unit |
|-----------|-------|------|------|------|
| | Min. | Typ. | Max. | |
| T1 | 0.5 | - | 10 | [ms] |
| T2 | 30 | 40 | 50 | [ms] |
| T3 | 200 | - | - | [ms] |
| T4 | 0.5 | - | 10 | [ms] |
| T5 | 10 | - | - | [ms] |
| T6 | 10 | - | - | [ms] |
| T7 | 0 | - | - | [ms] |
| T8 | 10 | - | - | [ms] |
| T9 | - | - | 10 | [ms] |
| T10 | 110 | - | - | [ms] |
| T11 | 0 | 16 | 50 | [ms] |

Sunlight Readable LCDs With Optical Bonding + Touch Integration

Specification

| | | | | |
|-----|------|---|----|------|
| T12 | - | - | 10 | [ms] |
| T13 | 1000 | - | - | [ms] |

7. Connector & Pin Assignment

Physical interface is described as for the connector on module. These connectors are capable of accommodating the following signals and will be following components.

7.1 TFT LCD Module

7.1.1 Connector

| Connector Name / Designation | Interface Connector |
|------------------------------|-------------------------------|
| Manufacturer | JAE or Compatible |
| Type Part Number | FI-XB30SSL-HF15 or Compatible |
| Mating Housing Part Number | JAE FI-X30HL or Compatible |

7.1.2 Pin Assignment

| Pin# | Signal Name | Pin# | Signal Name |
|------|------------------|------|-------------|
| 1 | RxOIN0- | 2 | RxOIN0+ |
| 3 | RxOIN1- | 4 | RxOIN1+ |
| 5 | RxOIN2- | 6 | RxOIN2+ |
| 7 | GND | 8 | RxOCLKIN- |
| 9 | RxOCLKIN+ | 10 | RxOIN3- |
| 11 | RxOIN3+ | 12 | RxEIN0- |
| 13 | RxEIN0+ | 14 | GND |
| 15 | RxEIN1- | 16 | RxEIN1+ |
| 17 | GND | 18 | RxEIN2- |
| 19 | RxEIN2+ | 20 | RxECLKIN- |
| 21 | RxECLKIN+ | 22 | RxEIN3- |
| 23 | RxEIN3+ | 24 | GND |
| 25 | GND (AGMODE+HVS) | 26 | NC |
| 27 | GND | 28 | VCC |
| 29 | VCC | 30 | VCC |

Sunlight Readable LCDs With Optical Bonding + Touch Integration

Specification

7.2 Backlight Unit

Physical interface is described as for the connector on module. These connectors are capable of accommodating the following signals and will be following components.

| Connector Name / Designation | Lamp Connector |
|-------------------------------|------------------------------|
| Manufacturer | E&T or compatible |
| Connector Model Number | 3806K-F06Y-03R or compatible |
| Mating Connector Model Number | H208K-P06N-02B or compatible |

7.2.1 Signal for LED driver connector

| Pin# | Symbol | Signal Name |
|------|------------|----------------|
| 1 | VCC | 12V |
| 2 | VCC | 12V |
| 3 | GND | GND |
| 4 | GND | GND |
| 5 | Display on | 5V-On / 0V-Off |
| 6 | Dimming | PWM Dimming |

Sunlight Readable LCDs With Optical Bonding + Touch Integration

Specification

8. Reliability Test

Environment test conditions are listed as following table.

| Items | Required Condition | Note |
|-----------------------------------|---|------|
| Temperature Humidity Bias (THB) | Ta= 50□, 80%RH, 300 hrs | |
| High Temperature Operation (HTO) | Ta= 50□, 300 hrs | |
| Low Temperature Operation (LTO) | Ta= 0□, 300 hrs | |
| High Temperature Storage (HTS) | Ta= 60□, 300 hrs | |
| Low Temperature Storage (LTS) | Ta= -20□, 300 hrs | |
| Vibration Test (Non-operation) | Acceleration: 1.5 G Wave: Random Frequency: 10 - 200 - 10 Hz Sweep: 30 Minutes each Axis (X, Y, Z) | |
| Shock Test (Non-operation) | Acceleration: 50 G Wave: Half-sine Active Time: 20 ms Direction: ±X, ±Y, ±Z (one time for each Axis) | |
| Drop Test | Height: 60 cm, package test | |
| Thermal Shock Test (TST) | -20□/30min, 60□/30min, 100 cycles | |
| On/Off Test | On/10sec, Off/10sec, 30,000 cycles | |
| ESD | Contact Discharge: ± 8KV, 150pF(330Ω) 1sec, 8 points, 25 times/ point. | 1 |
| | Air Discharge: ± 15KV, 150pF(330Ω) 1sec 8 points, 25 times/ point. | |
| EMI | 30-230 MHz, limit 40 dBu V/m, 230-1000 MHz, limit 47 dBu V/m | |
| Altitude Test | Operation:10,000 ft Non-Operation:30,000 ft | |

Note1: According to EN61000-4-2, ESD class B: Some performance degradation allowed. No data lost
Self-recoverable. No hardware failures.

Note2:

- Water condensation is not allowed for each test items.
- Each test is done by new TFT-LCD module. Don't use the same TFT-LCD module repeatedly for reliability test.
- The reliability test is performed only to examine the TFT-LCD module capability.
- To inspect TFT-LCD module after reliability test, please store it at room temperature and room humidity for 24 hours at least in advance.
- No function failure occurs.

Sunlight Readable LCDs With Optical Bonding + Touch Integration

Specification

9. Label and Packaging

9.1 Shipping Label (on the rear side of TFT-LCD display)

The shipping label format is shown as below.

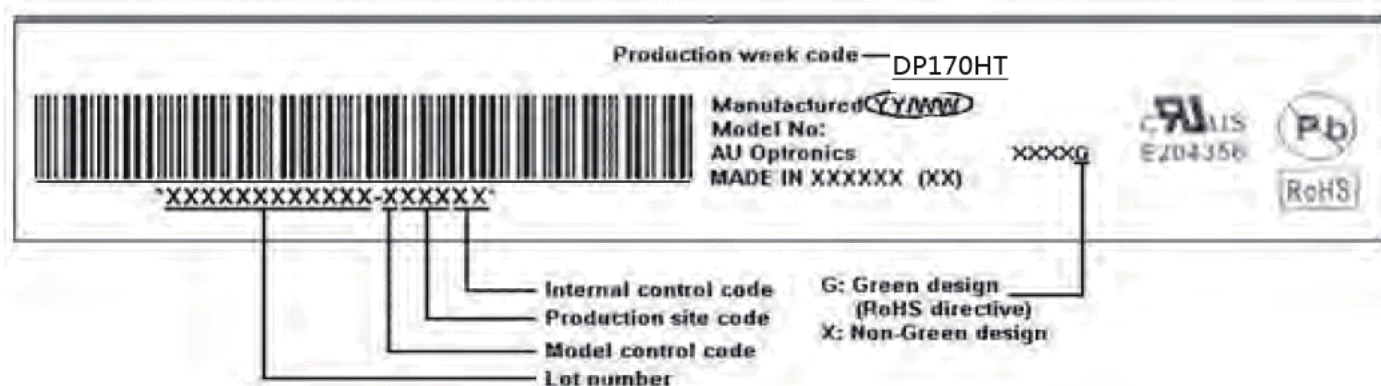

9.2 Carton Package

Max capacity : 8 TFT-LCD module per carton

Max weight: 18.5 kg per carton

Outside dimension of carton: 426(L)mm*270(W)mm*375(H)mm

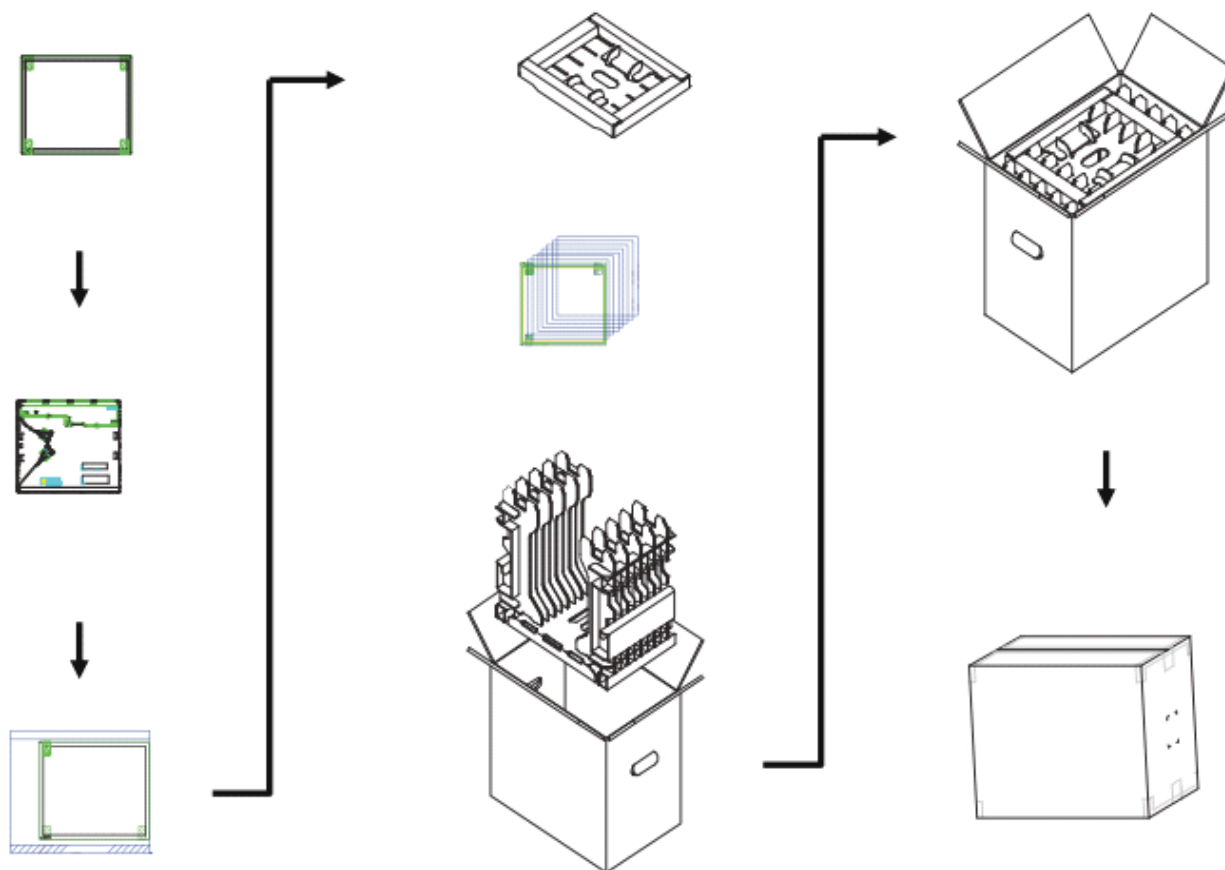

Sunlight Readable LCDs With Optical Bonding + Touch Integration

Specification

10. Mechanical Characteristics

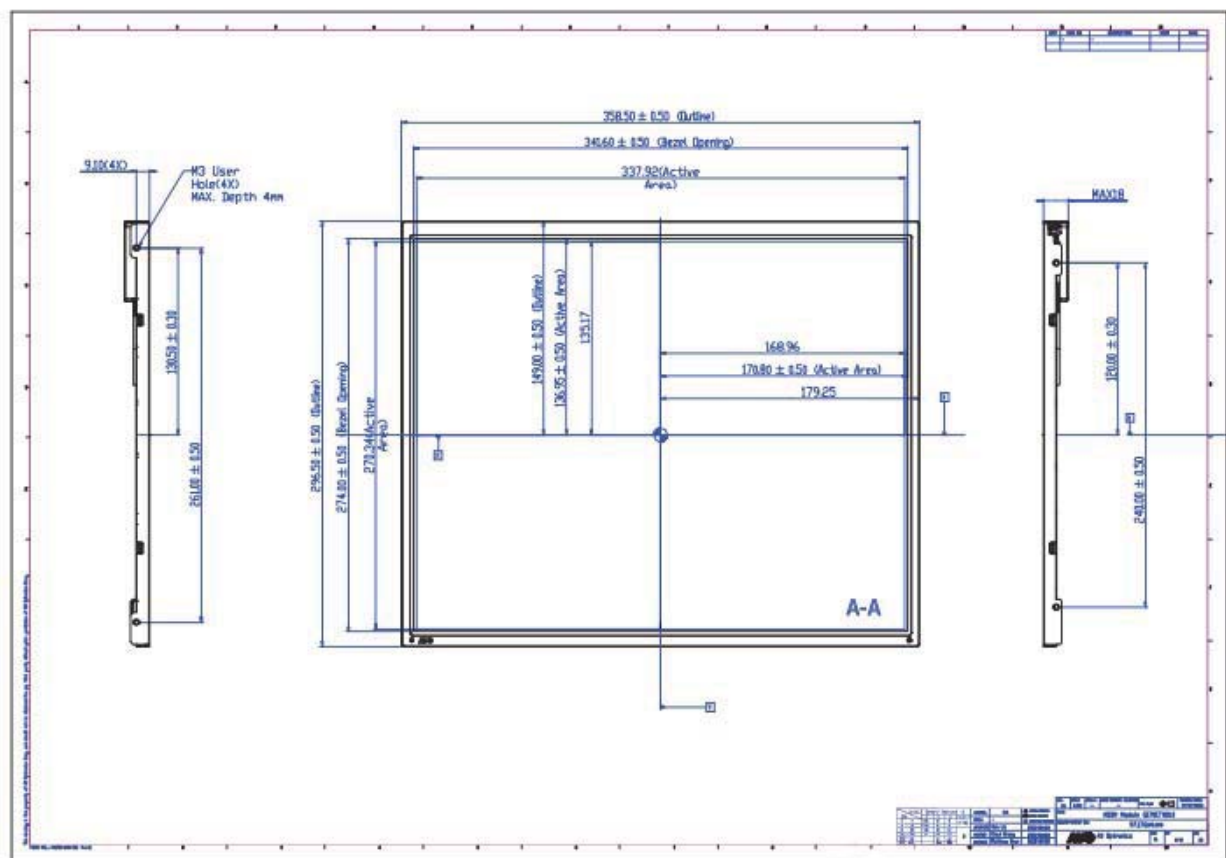

Sunlight Readable LCDs With Optical Bonding + Touch Integration

Specification

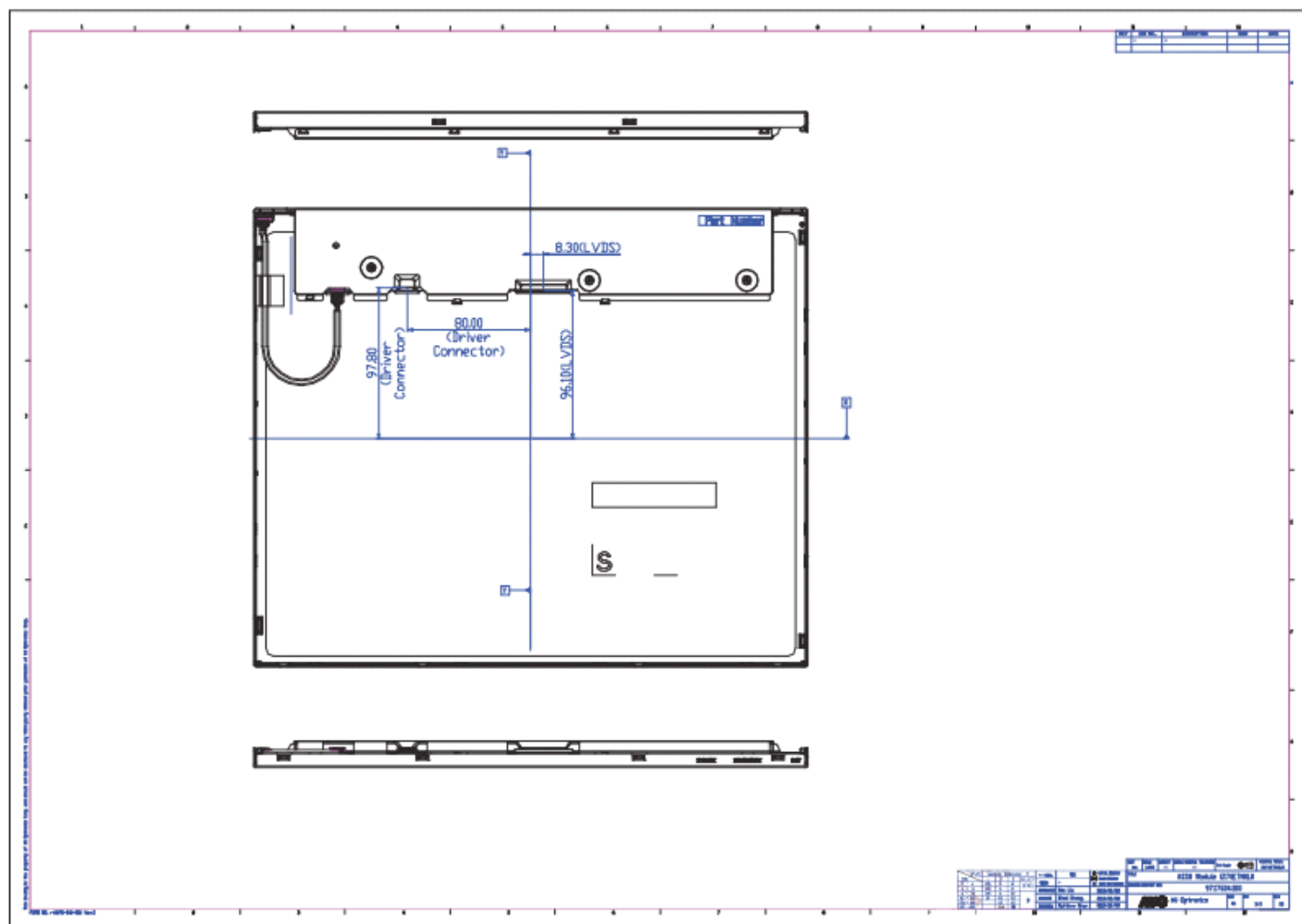

Sunlight Readable LCDs With Optical Bonding + Touch Integration