

DP 2012 Series

Multilayer Chip Diplexers

Features

- ❖ Monolithic structure including one low-pass and one band-pass filters with loss pole at adjacent passband.

Applications

- ❖ Dual-band / dual-mode 2.4GHz/5GHz WLAN



Specifications

Part Number	Passband (MHz)	Insertion Loss (dB)	Attenuation I (dB)	Attenuation II (dB)	Passband VSWR	Q'ty/ Reel (pcs)
DP2012-E2455BB	2400~2500	0.7 max.	18 min. @ 4.8 ~ 6.0 GHz	18 min. @ 7.2 ~ 7.5GHz	2.0 max.	4,000
	4900~5900	1.0 max.	19 min. @ 1.8 ~ 2.5 GHz	25 ref. @ 10.3 ~ 10.7GHz	2.0 max.	

Operating Temperature Range : -40 ~ +85 °C
 Storage Temperature Range : +5 ~ +35 °C, Humidity 45~75%RH
 Storage Period : 12 months max.
 Power Capacity : 2W max.

Part Number

DP **2012** - **E** **2455** **BB** **□** **/LF**
 ① ② ③ ④ ⑤ ⑥ ⑦

① Type	DP : Diplexer	② Dimensions (L x W)	2.0 x 1.2 mm
③ Material Code	E	④ Frequency Range	2455=2400MHz /5500MHz
⑤ Specification Code	BB	⑥ Packaging	T: Tape & Reel B: Bulk
⑦ Soldering	=lead-containing /LF=lead-free		

Terminal Configuration

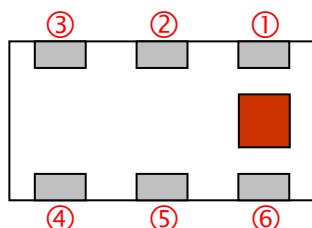

No.	Terminal Name	No.	Terminal Name
①	Higher Freq. Port (P1)	④	GND
②	GND	⑤	Common Port (P2)
③	Lower Freq. Port (P3)	⑥	GND

Dimensions and Recommended PC Board Pattern

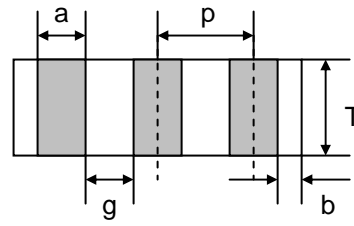
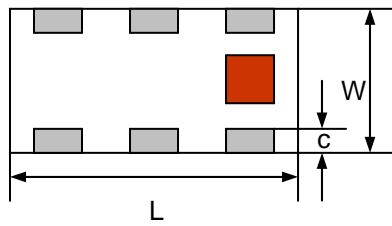

Unit : mm

Mark	L	W	T	a	b	c	g	p
Dimensions	2.0 ± 0.1	1.25 ± 0.1	0.55 ± 0.1	0.3 ± 0.1	0.2 ± 0.1	$0.3+0.1 / -0.2$	0.35 ± 0.1	0.65 ± 0.05

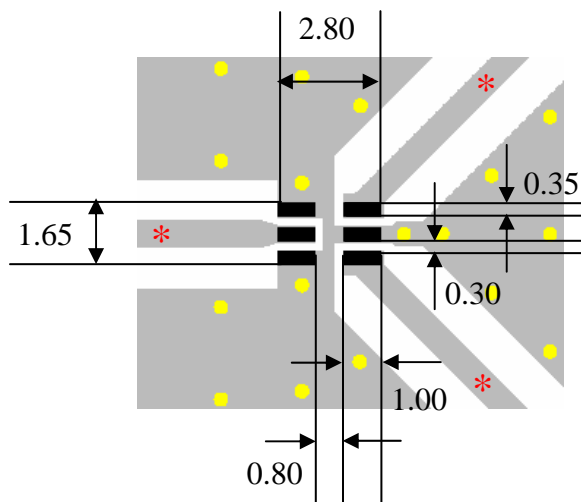

* Line width should be designed to match 50Ω characteristic impedance, depending on PCB material and thickness.

Measuring Diagram

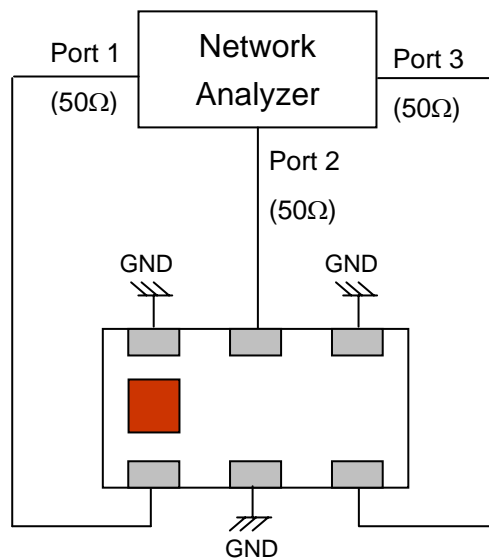

Typical Electrical Characteristics (T=25°C)

Attenuation

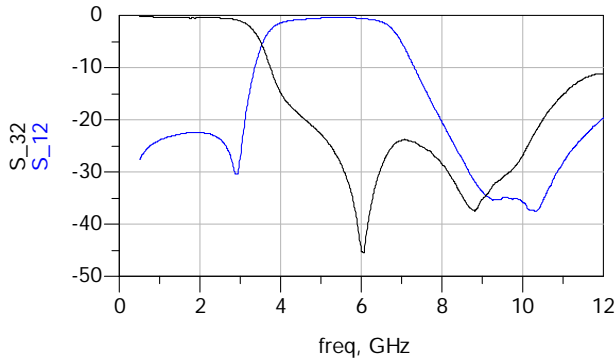

Return Loss

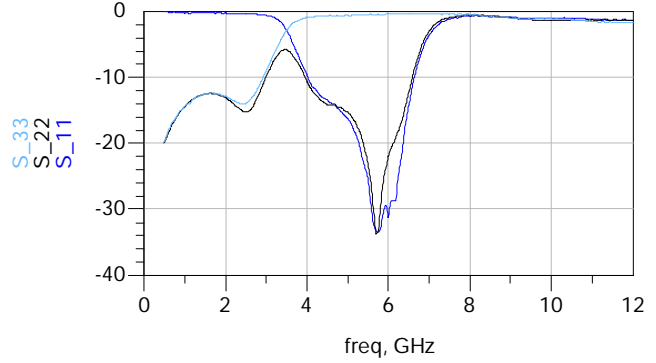

Notes

❖ The contents of this data sheet are subject to change without notice. Please confirm the specifications and delivery conditions when placing your order.

Advanced Ceramic X Corp.

16 Tzu Chiang Road, Hsinchu Industrial District Hsinchu Hsien 303, Taiwan

TEL:886-3-5987008 FAX:886-3-5987001

E-mail: acx@acxc.com.tw <http://www.acxc.com.tw>