

Specification

DP**DOPOINT****215****Size****FHD****Pixel**

A:640*480

B:800*480

C:800*600

D:1024*600

E:1024*768

F:1280*768

G:1280*800

H:1280*1024

HD:1366*768

J:1600*1200

K:1920*1200

FHD:1920*1080

I**Mode**

T: TN

I: IPS

Product Order Number	Description
DP215FHDI-XXXX	<ul style="list-style-type: none"> • IPS Normally Black • 0°C to +50°C Operating Temperature • Viewing Angle L/R/U/D - 89/89/89/89 • Luminance – 1500 cd/m² • Contrast Ratio – 1000:1
DP215FHDI-TXXX	Resistive + Capacitive Touch by Optical Bonding
DP215FHDI-HXXX	Extended temp (Add Heater by Optical Bonding) -40°C to +80°C Operating Temperature
DP215FHDI-EXXX	Integrated Front Optical EMI Filter by Optical Bonding
DP215FHDI-ARAG	Anti-Reflective + Anti-Glare Surface Treatment
DP215FHDI-NVIS	Integrated NVIS Optical Filter

Sunlight Readable LCDs With Optical Bonding + Touch Integration

Specification

1. General Description

DP215FHDI is a Color Active Matrix Liquid Crystal Display with Light Emitting Diode (White LED) backlight system without LED driver. The matrix employs a-Si Thin Film Transistor as the active element.

It is a transmissive type display operating in the normally white mode. It has a 21.5inch diagonally measured active display area with Full HD resolution (1080 vertical by 1920 horizontal pixel array)

Each pixel is divided into Red, Green and Blue sub-pixels or dots which are arranged in vertical stripes.

Gray scale or the brightness of the sub-pixel color is determined with a 8bit gray scale signal for each dot, t h s , p r e s e n t i n g a p a l e t t e o f m o r e t h a n 16M c o l o r s . .

It has been designed to apply the 8bit 4Lane Display port interface.

I t i s i n t e n d e d t o s u p p o r t d i s p l a y s w h e r e h i g h b r i g h t n e s s , s u p e r w i d e v i e w i n g a n g l e , high color saturation, and high color are important.

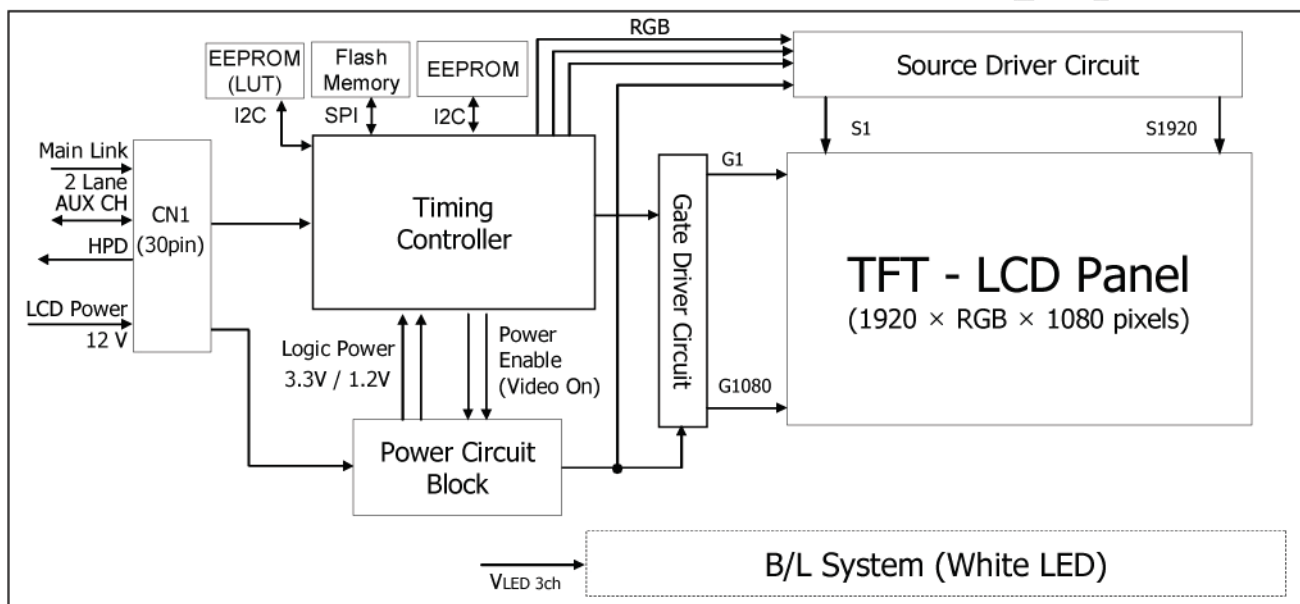

[Figure 1] Block diagram

General Features

Active Screen Size	21.46 inches(545.22mm) diagonal
Outline Dimension	495.6(H) x 305.25(V) x 15.8(D) mm(Typ.)
Pixel Pitch	0.2475mm x 0.2475mm
Pixel Format	1920 horiz. By 1080 vert. Pixels RGB stripes arrangement
Color Depth	8-bit, 16,777,216 colors
Luminance, White	1500cd/m ² (5point Avg.)
Viewing Angle(CR>10)	View Angle Free (R/L 178(Typ.), U/D 178(Typ.))
Power Consumption	Total 52.25 Watt (Max.) (7.5 Watt @V _{LCD} , Max 44.75 Watt_ Duty 100% of DC 250 mA_ w/o driver)
Weight	2300g (typ.)
Display Operating Mode	Transmissive mode, normally black
Surface Treatment	Hard coating(2H), Glare (Low Reflection treatment of the front polarizer)

Sunlight Readable LCDs With Optical Bonding + Touch Integration

Specification

2. Absolute Maximum Ratings

The following are maximum values which, if exceeded, may cause faulty operation or damage to the unit.

Table 1. ABSOLUTE MAXIMUM RATINGS

Parameter	Symbol	Values		Units	Notes
		Min	Max		
Power Input Voltage	V _{LCD}	-0.3	14	V _{dc}	at 25 ± 2°C
Operating Temperature	T _{OP}	0	50	°C	1
Storage Temperature	T _{ST}	-20	60	°C	
Operating Ambient Humidity	H _{OP}	10	90	%RH	
Storage Humidity	H _{ST}	10	90	%RH	

Note.

- Temperature and relative humidity range are shown in the figure below.
Wet bulb temperature should be 39 °C Max, and no condensation of water.
- Storage condition is guaranteed under packing condition.

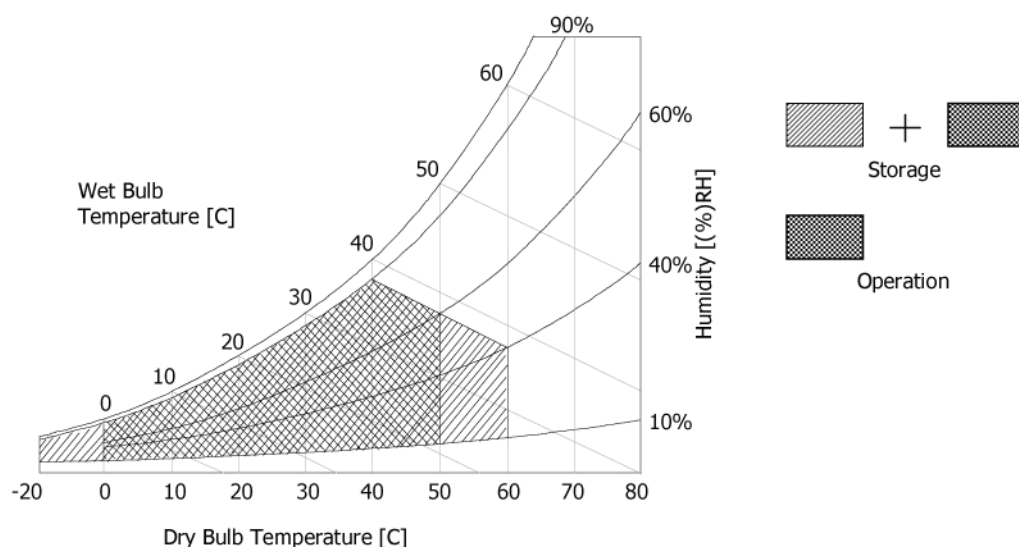

[Figure 2] Temperature and relative humidity

Sunlight Readable LCDs With Optical Bonding + Touch Integration

Specification

3. Electrical Specifications

3-1. Electrical Characteristics

It requires two power inputs. One is employed to power the LCD electronics and to drive the TFT array and liquid crystal. The second input power for the WLED.

Table 2-1. ELECTRICAL CHARACTERISTICS

Parameter	Symbol	Values			Unit	Notes
		Min	Typ	Max		
MODULE :						
Power Supply Input Voltage	V _{LCD}	11.4	12.0	12.6	Vdc	
Permissive Power Input Ripple	V _{RF}	-	-	400	mV	
Power Supply Input Current	I _{LCD}	310	387	464	mA	1
		416	520	624	mA	2
Power Consumption	PLCD		4.64	5.57	Watt	1
	PLCD		6.24	7.50	Watt	2
Rush current	I _{RUSH}	-	-	3.0	A	3

Note.

1. The specified current and power consumption are under the $V_{LCD}=12.0V$, $25 \pm 2^{\circ}C$, $f_v=60Hz$ condition whereas mosaic pattern(8 x 6) is displayed and f_v is the frame frequency.
2. The current is specified at the maximum current pattern.
3. The duration of rush current is about 2ms and rising time of power Input is 1ms(min.)

White : 255Gray
Black : 0Gray

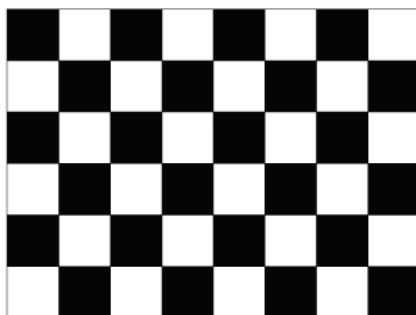

Mosaic Pattern(8 x 6)

Maximum current pattern



White Pattern

Sunlight Readable LCDs With Optical Bonding + Touch Integration

Specification

Table 2-2. LED Bar ELECTRICAL CHARACTERISTICS

Items	Symbol	Spec			Unit	Remark	Notes
		Min	Typ	Max			
LED String Voltage	V_S	55	58	61	Vrms	Ta=25℃, at DC 350 mA	2,7
LED Bar Voltage	V_{Bar}	-	173	179	Vrms	Ta=25℃, at DC 350 mA	3,7
LED String Power	P_S	19.25	20.30	21.35	W	Ta=25℃, at DC 350 mA	3,6,7
LED Bar Power	P_L	-	60.55	62.65	W	Ta=25℃, at DC 350 mA	4,6,7
BL Power	P_{BL}	-	43.25	44.75	W	Ta=25℃, at Duty 100% of DC 250 mA	6,7
LED Life Time	LED_LT	39,000		-	Hrs	Ta=25℃, at Duty 100% of DC 250 mA	5,7
LED Junction Temperature	T_j			150	℃	-	7

LED driver design guide

: The design of the LED driver must have specifications for the LED in LCD Assembly.

The performance of the LED in LCM, for example life time or brightness, is extremely influenced by the characteristics of the LED driver.

So all the parameters of an LED driver should be carefully designed and output current should be Constant current control.

Please control feedback current of each string individually to compensate the current variation among the strings of LEDs.

When you design or order the LED driver, please make sure unwanted lighting caused by the mismatch of the LED and the LED driver (no lighting, flicker, etc) never occurs.

When you confirm it, the LCD module should be operated in the same condition as installed in your instrument.

- Specified values are for a single LED bar.
- The specified current is input LED chip 100% duty current.
- The specified voltage is input LED string and Bar voltage at typical 350 mA 100% duty current.
- The specified power consumption is input LED bar power consumption at typical 350 mA 100% duty current.
- The life is determined as the time at which luminance of the LED is 50% compared to that of initial value at the typical LED current on condition of continuous operating at $25 \pm 2^\circ\text{C}$.
- The LED power consumption shown above does not include loss of external driver.
The used LED BL current is the LED typical current.
String Power Consumption is calculated with $P_S = V_S \times 350\text{mA}$
Bar Power Consumption is calculated with $P_L = V_{Bar} \times 350\text{mA}$
BL Power Consumption is calculated with $P_{BL} = V_{Bar} \times 250\text{mA}$
- LED operating DC Forward Current and Junction Temperature must not exceed LED Max Ratings.

Sunlight Readable LCDs With Optical Bonding + Touch Integration

Specification

3-2. Interface Connections

3-2-1. LCD Module

- LCD Connector(CN1) :FI-X30SSL-HF (JAE), MDF76LBRW-30S-1H (Hirose) or Equivalent
- Mating Connector : FI-XC30C2L (Manufactured by JAE) or Equivalent

Table 3. MODULE CONNECTOR(CN1) PIN CONFIGURATION

No	Symbol	Description	No	Symbol	Description
1	DDC_SCL	DDC Clock	16	Lane3P	True Signal for Main Link 3
2	DDC_SDA	DDC Data	17	Lane3N	Component Signal for Main Link 3
3	GND	High Speed Ground for Auxiliary Channel	18	GND	High Speed Ground
4	AUX_CH_N	Component Signal for Auxiliary Channel	19	SPDIF	Audio output from DP RX
5	AUX_CH_P	True Signal for Auxiliary Channel	20	VIDEO_ON	Video status from DP RX
6	GND	High Speed Ground for Main Link 0	21	HPD	Hot Plug Detect Signal
7	Lane0P	True Signal for Main Link 0	22	GND	GND for main power
8	Lane0N	Component Signal for Main Link 0	23	GND	GND for main power
9	GND	High Speed Ground for Main Link 1	24	GND	GND for main power
10	Lane1P	True Signal for Main Link 1	25	GND	GND for main power
11	Lane1N	Component Signal for Main Link 1	26	VLCD	12V for LCM main power
12	GND	High Speed Ground for Main Link 2	27	VLCD	12V for LCM main power
13	Lane2P	True Signal for Main Link 2	28	VLCD	12V for LCM main power
14	Lane2N	Component Signal for Main Link 2	29	VLCD	12V for LCM main power
15	GND	High Speed Ground for Main Link 3	30	VSYNC	Sync. signal

- Note: 1. All GND(ground) pins should be connected together and to Vss which should also be connected to the LCD's metal frame.
2. All VLCD (power input) pins should be connected together.

[Figure 3] User Connector diagram

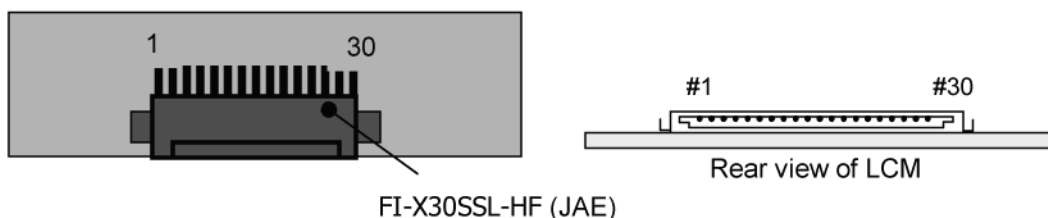

Sunlight Readable LCDs With Optical Bonding + Touch Integration

Specification

3-2-2. User Connector

This connector is used for synchronized LED Driver.
 The connector is 53780-8604. (Manufactured by MOLEX)

Table 4. LED SYNCHRONIZED CONNECTOR(CN3) PIN CONFIGURATION

Pin	Symbol	Description	NOTES
1	GND	Ground	
2	EN	Enable	
3	PWM	PWM for synchronized LED Driver	1
4	GSP	GSP for synchronized LED Driver	2

Note: 1. PWM signal follows multiplied Horizontal frequency and level is 3.3V TTL level.
 2. GSP frequency follows refresh time and level is 3.3V TTL level and high width is 1/(Horizontal freq).

Sunlight Readable LCDs With Optical Bonding + Touch Integration

Specification

3-2-3. Backlight Interface

Driver connector: H401K-D06N-12B (Manufactured by E&T)
 Mating Connector: 4530K-F06N-01R (Manufactured by E&T)

Table 5. LED DRIVER CONNECTOR PIN CONFIGURATION

Pin	Symbol	Description	NOTES
1	LED1-	LED channel 1 cathode – Left bar	
2	LED2+	LED channel 2 Anode – Left bar	
3	LED3-	LED channel 3 cathode – Left bar	
4	LED1+	LED channel 1 Anode – Right bar	
5	LED2-	LED channel 2 cathode – Right bar	
6	LED3+	LED channel 3 Anode – Right bar	

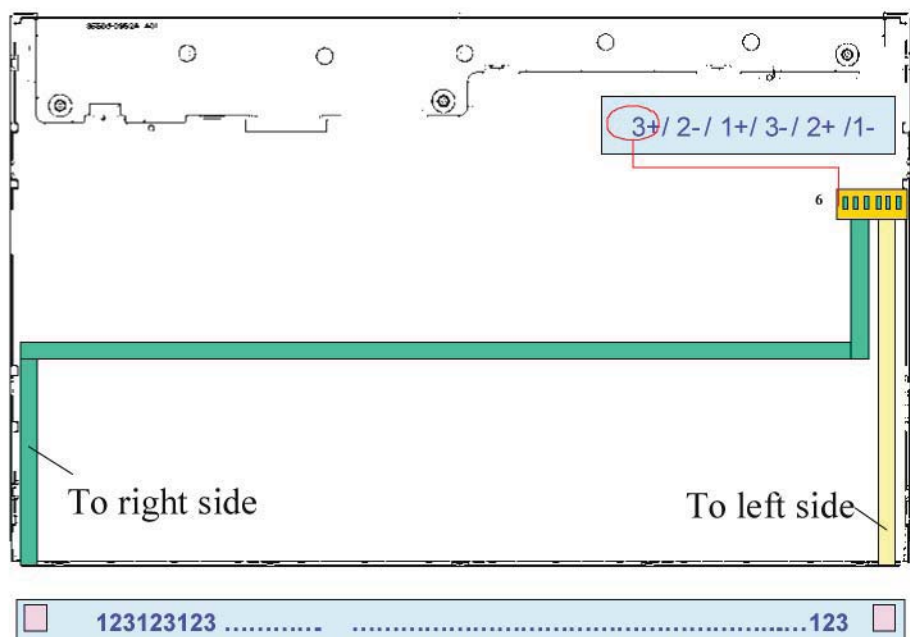

[Figure 4] LED Driver Connector Pin

Sunlight Readable LCDs With Optical Bonding + Touch Integration

Specification

3-3. Signal Timing Specifications

All of the interface signal timing should be satisfied with the following specifications for it's proper operation.

Table 6. TIMING TABLE

ITEM	Symbol		Min	Typ	Max	Unit	Note
DCLK	Period	tCLK	-	7.22	-	ns	
	Frequency	-	-	138.5	-	MHz	
Horizontal	total	tHP	-	2080	-	tCLK	
	Frequency	fH	-	66.59	-	KHz	
	Blanking		-	160	-	tCLK	
	valid	tWH	-	1920	-	tCLK/2	
Vertical	total	tVP	-	1111	-	tHP	
	Frequency	fV	-	60	-	Hz	
	Blanking		-	31	-	tHP	
	valid	tWV	-	1080	-	tHP	

Note: Hsync period and Hsync width-active should be even number times of tCLK. If the value is odd number times of tCLK, display control signal can be asynchronous. In order to operate this LCM a Hsync, Vsync, and DE(data enable) signals should be used.

1. The performance of the electro-optical characteristics may be influenced by variance of the vertical refresh rates.
2. Vsync and Hsync should be keep the above specification.
3. Hsync Period, Hsync Width, and Horizontal Back Porch should be any times of of character number(8).
4. The polarity of Hsync, Vsync is not restricted.

Sunlight Readable LCDs With Optical Bonding + Touch Integration

Specification

3-4. Signal Timing Waveforms

1. Dclk, DE, DATA waveforms

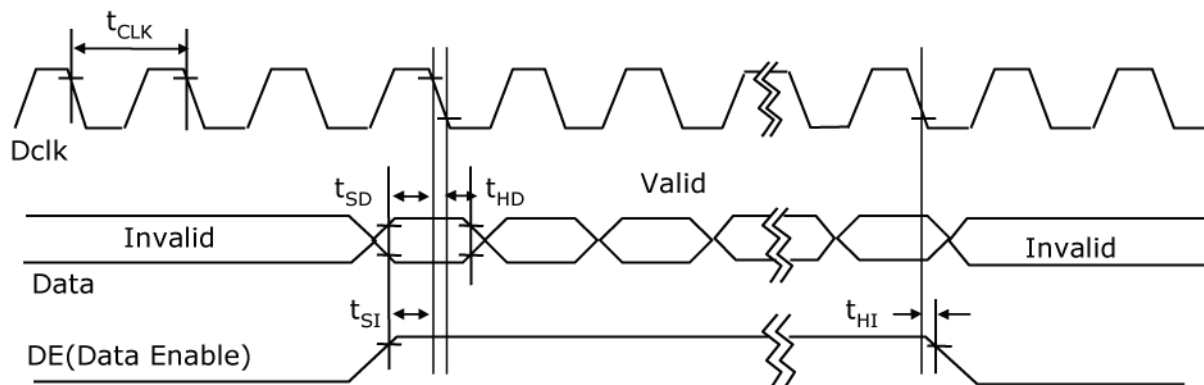

2. Horizontal waveform

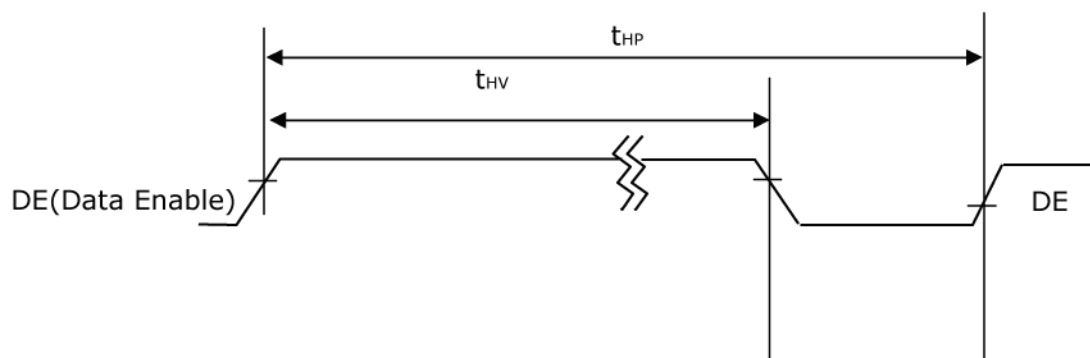

3. Vertical waveform

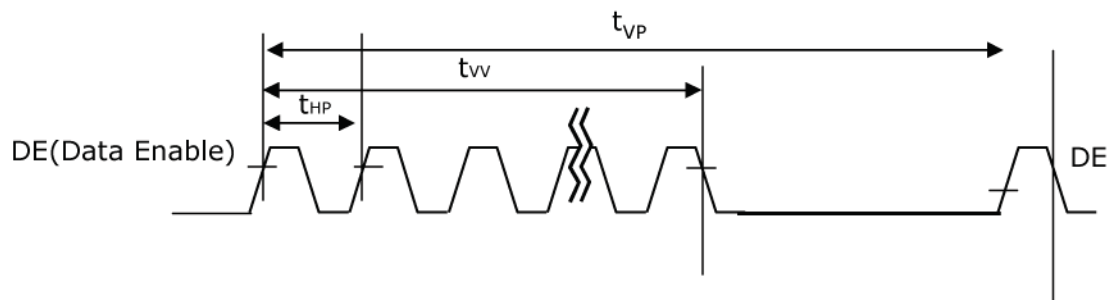

Sunlight Readable LCDs With Optical Bonding + Touch Integration

Specification

3-5. Color Input Data Reference

The Brightness of each primary color(red,green,blue) is based on the 8-bit gray scale data input for the color; the higher the binary input, the brighter the color. The table below provides a reference for color versus data input.

Table 7. COLOR DATA REFERENCE

Color		Input Color Data																							
		RED								GREEN								BLUE							
		MSB							LSB	MSB							LSB	MSB							LSB
R7	R6	R5	R4	R3	R2	R1	R0	G7	G6	G5	G4	G3	G2	G1	G0	B7	B6	B5	B4	B3	B2	B1	B0		
Basic Color	Black	0	0	0	0	0	0	0	0	0	0	0	0	0	0	0	0	0	0	0	0	0	0	0	0
	Red (255)	1	1	1	1	1	1	1	1	0	0	0	0	0	0	0	0	0	0	0	0	0	0	0	0
	Green (255)	0	0	0	0	0	0	0	0	1	1	1	1	1	1	1	1	0	0	0	0	0	0	0	0
	Blue (255)	0	0	0	0	0	0	0	0	0	0	0	0	0	0	0	0	1	1	1	1	1	1	1	1
	Cyan	0	0	0	0	0	0	0	0	1	1	1	1	1	1	1	1	1	1	1	1	1	1	1	1
	Magenta	1	1	1	1	1	1	1	1	0	0	0	0	0	0	0	0	1	1	1	1	1	1	1	1
	Yellow	1	1	1	1	1	1	1	1	1	1	1	1	1	1	1	1	0	0	0	0	0	0	0	0
	White	1	1	1	1	1	1	1	1	1	1	1	1	1	1	1	1	1	1	1	1	1	1	1	1
RED	RED (000) Dark	0	0	0	0	0	0	0	0	0	0	0	0	0	0	0	0	0	0	0	0	0	0	0	0
	RED (001)	0	0	0	0	0	0	0	1	0	0	0	0	0	0	0	0	0	0	0	0	0	0	0	0
							
	RED (254)	1	1	1	1	1	1	1	0	0	0	0	0	0	0	0	0	0	0	0	0	0	0	0	0
	RED (255)	1	1	1	1	1	1	1	1	0	0	0	0	0	0	0	0	0	0	0	0	0	0	0	0
GREEN	GREEN (000) Dark	0	0	0	0	0	0	0	0	0	0	0	0	0	0	0	0	0	0	0	0	0	0	0	0
	GREEN (001)	0	0	0	0	0	0	0	0	0	0	0	0	0	0	0	1	0	0	0	0	0	0	0	0
							
	GREEN (254)	0	0	0	0	0	0	0	0	1	1	1	1	1	1	1	0	0	0	0	0	0	0	0	0
	GREEN (255)	0	0	0	0	0	0	0	0	1	1	1	1	1	1	1	1	0	0	0	0	0	0	0	0
BLUE	BLUE (000) Dark	0	0	0	0	0	0	0	0	0	0	0	0	0	0	0	0	0	0	0	0	0	0	0	0
	BLUE (001)	0	0	0	0	0	0	0	0	0	0	0	0	0	0	0	0	0	0	0	0	0	0	0	1
							
	BLUE (254)	0	0	0	0	0	0	0	0	0	0	0	0	0	0	0	0	1	1	1	1	1	1	1	0
	BLUE (255)	0	0	0	0	0	0	0	0	0	0	0	0	0	0	0	0	1	1	1	1	1	1	1	1

Sunlight Readable LCDs With Optical Bonding + Touch Integration

Specification

3-6. Power Sequence

3-6-1. Power Sequence

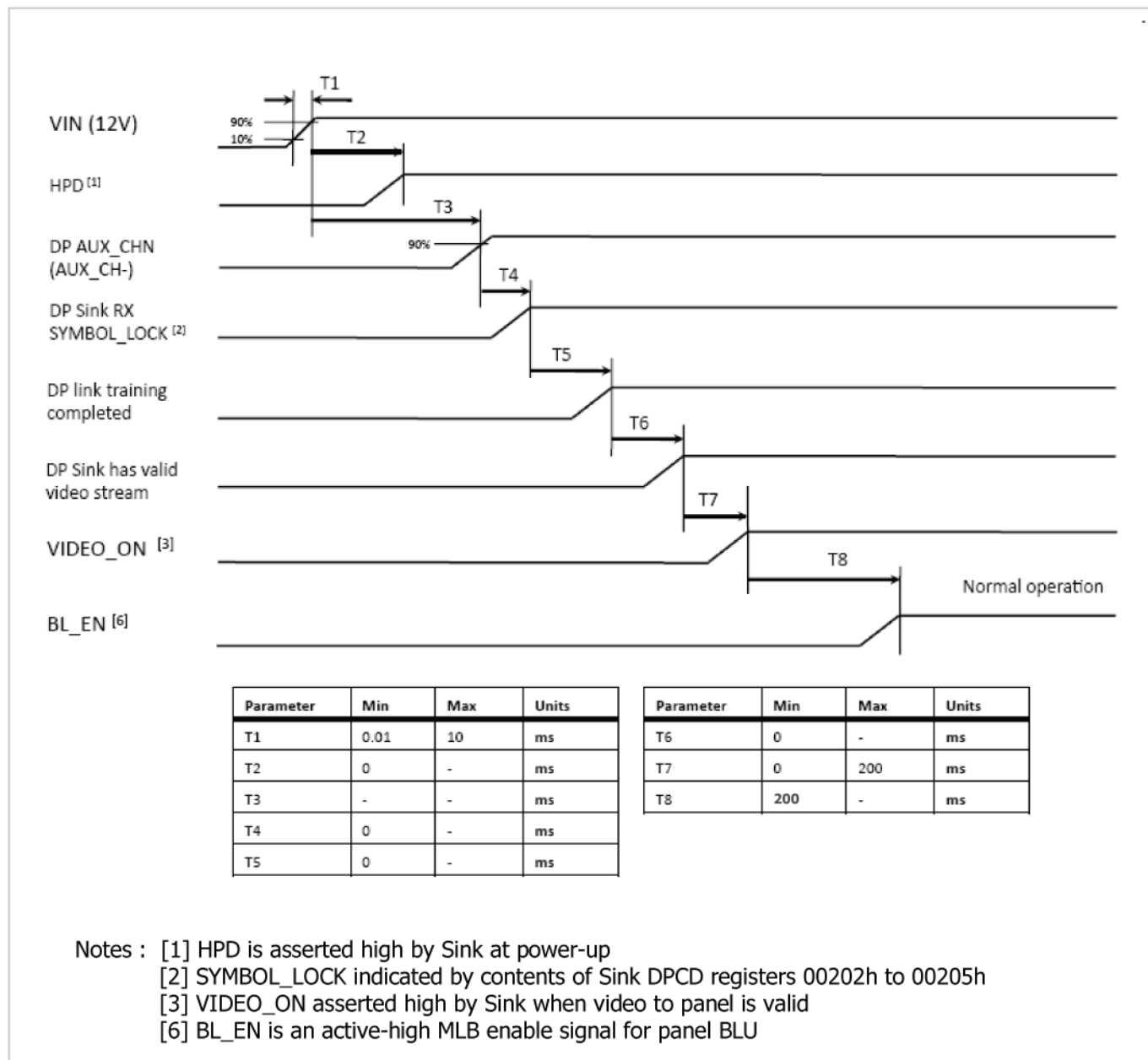

- Notes :
1. Please avoid floating state of interface signal at invalid period.
 2. When the interface signal is invalid, be sure to pull down the power supply for LCD V_{LCD} to 0V.
 3. LED power must be turn on after power supply for LCD and interface signal are valid.

Specification

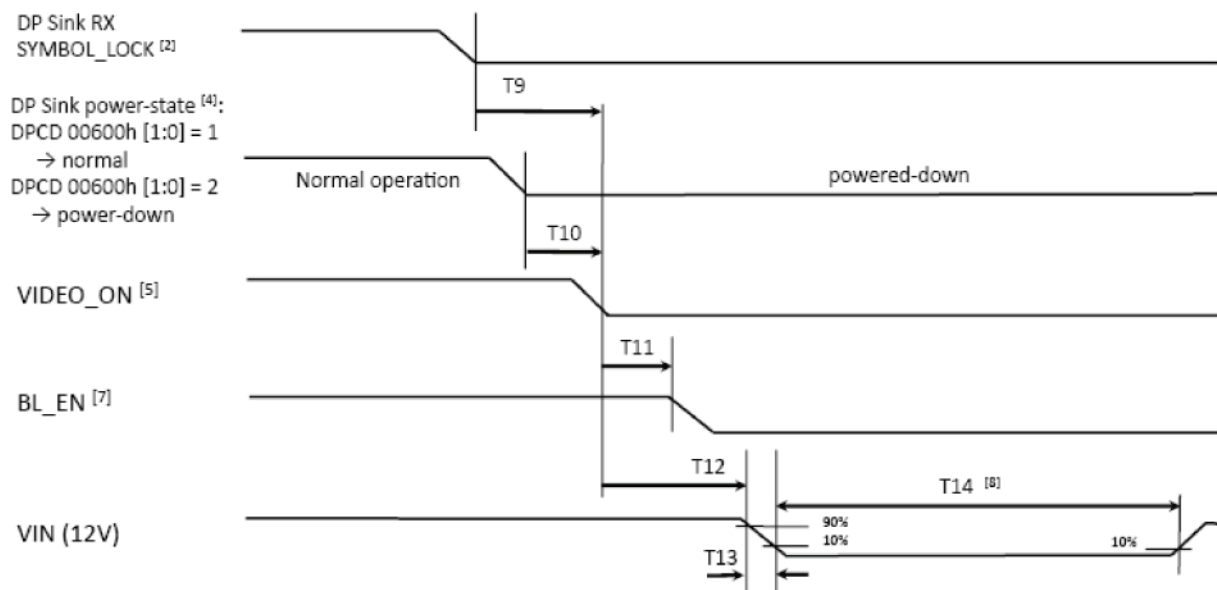

Parameter	Min	Max	Units
T9	0	10	ms
T10	0	5	ms
T11	-	10	ms
T12	0	-	ms
T13	0.01	1000	ms
T14	250	-	ms

- Notes :
- [2] SYMBOL_LOCK indicated by contents of Sink DPCD registers 00202h to 00205h
 - [4] Power-state set by Source in Sink DPCD register 00600h
 - [5] VIDEO_ON asserted low by Sink because of :
 - 1) loss of SYMBOL_LOCK or
 - 2) DP Sink is powered down
 - [7] BL_EN must be asserted low by system as rapidly as possible when video is invalid to avoid visible artifacts
 - [8] T14 defines minimum off-time for 12V power
 - [9] min. times of 0 indicate precedence ordering of events, e.g. where actual timing is TBD

Specification

3-6-2. State Machine

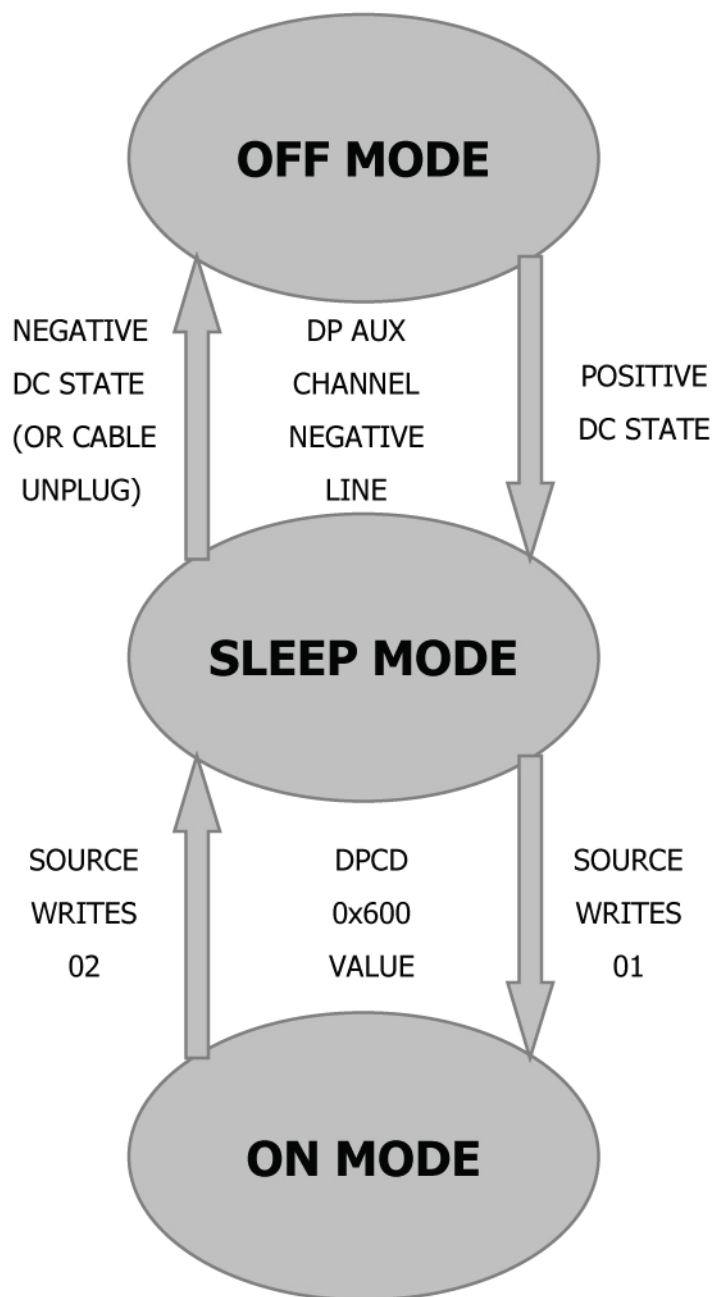

Sunlight Readable LCDs With Optical Bonding + Touch Integration

Specification

4. Optical Specifications

Optical characteristics are determined after the unit has been 'ON' for approximately 70 minutes in a dark environment at $25 \pm 2^\circ\text{C}$. The values specified are at an approximate distance 50cm from the LCD surface at a viewing angle of Φ and θ equal to 0° and aperture 1 degree.

FIG. 8 presents additional information concerning the measurement equipment and method.

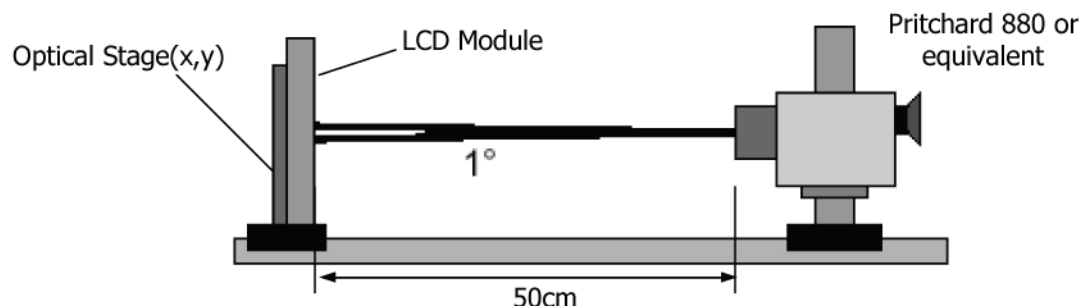

[Figure 5] Optical characteristic measurement equipment and method

Table 8. OPTICAL CHARACTERISTICS

($T_a = 25^\circ\text{C}$, $V_{\text{LCD}} = 12.0\text{V}$, $f_v = 60\text{Hz}$ Dclk=138.5MHz)

Parameter	Symbol	Values			Units	Notes	
		Min	Typ	Max			
Contrast Ratio	CR	700	1000	-		1	
Surface Luminance, white	L_{WH}	1400	1500	-	cd/m ²	2	
Luminance Variation	δ_{WHITE}			30	%	3	
Response Time	Rise Time	Tr_R	-	6.5	12	ms	4.1
	Decay Time	Tr_D	-	7.5	12	ms	4.1
Color Coordinates [CIE1931]	RED	R_x		0.651			
		R_y		0.333			
	GREEN	G_x		0.305			
		G_y	Typ	0.617	Typ		
	BLUE	B_x	-0.03	0.146	+0.03		
		B_y		0.050			
	WHITE	W_x		0.308			
	W_y		0.325				
Color Shift	Horizontal	θ_{CST_H}	-	178	-	Degree	5
	Vertical	θ_{CST_V}	-	178	-		
Viewing Angle (CR>10)							
General	Horizontal	θ_H	170	178	-	Degree	6
	Vertical	θ_V	170	178	-		
Effective	Horizontal	θ_{GMA_H}		178	-	Degree	7
	Vertical	θ_{GMA_V}		178	-		
Gray Scale				2.2			8

Sunlight Readable LCDs With Optical Bonding + Touch Integration

Specification

Notes 1. Contrast Ratio(CR) is defined mathematically as :

$$\text{Contrast Ratio} = \frac{\text{Surface Luminance with all white pixels}}{\text{Surface Luminance with all black pixels}}$$

It is measured at center point(Location P1)

2. Surface luminance(L_{WH}) is luminance value at 5 points average across the LCD surface 50cm from the surface with all pixels displaying white. For more information see FIG 9.

$$L_{WH} = \text{Average}[L_{on1}, L_{on2}, L_{on3}, L_{on4}, L_{on5}]$$

3. The variation in surface luminance, δ_{WHITE} is defined as :

$$\delta_{WHITE} = \frac{\text{Maximum}(L_{on1}, L_{on2}, \dots, L_{on13}) - \text{Minimum}(L_{on1}, L_{on2}, \dots, L_{on13})}{\text{Average}(L_{on1}, L_{on2}, \dots, L_{on5})} \times 100(\%)$$

Where L1 to L13 are the luminance with all pixels displaying white at 13 locations.

For more information see FIG 9.

4. Response time is the time required for the display to transition from black to white (Rise Time, Tr_R) and from white to black (Decay Time, Tr_D). For additional information see FIG 10

5. Color shift is the angle at which the color difference is lower than 0.04.

For more information see FIG 11.

- Color difference ($\Delta u'v'$)

$$u' = \frac{4x}{-2x + 12y + 3} \quad v' = \frac{9y}{-2x + 12y + 3}$$

$$\Delta u'v' = \sqrt{(u'_1 - u'_2)^2 + (v'_1 - v'_2)^2} \quad \begin{array}{l} u'_1, v'_1 : u'v' \text{ value at viewing angle direction} \\ u'_2, v'_2 : u'v' \text{ value at front } (\theta=0) \end{array}$$

- Pattern size : 25% Box size

- Viewing angle direction of color shift : Horizontal, Vertical

6. Viewing angle is the angle at which the contrast ratio is greater than 10. The angles are determined for the horizontal or x axis and the vertical or y axis with respect to the z axis which is normal to the LCD surface. For more information see FIG 12.

7. Effective viewing angle is the angle at which the gamma shift of gray scale is lower than 0.3.

For more information see FIG 13 and FIG 14.

8. Gray scale specification

Gamma Value is approximately 2.2. For more information see Table 10.



Sunlight Readable LCDs With Optical Bonding + Touch Integration

Specification

Measuring point for surface luminance & measuring point for luminance variation.

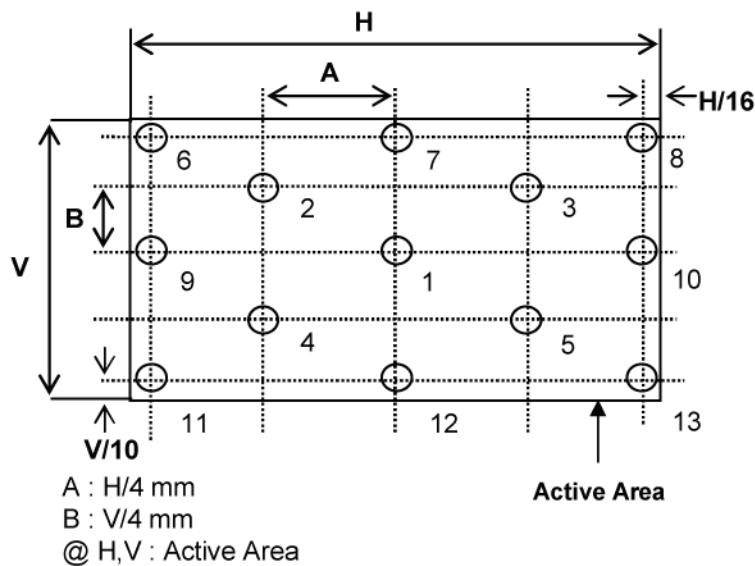

[FIG 6] Measure Point for Luminance

The response time is defined as the following figure and shall be measured by switching the input signal for "black" and "white".

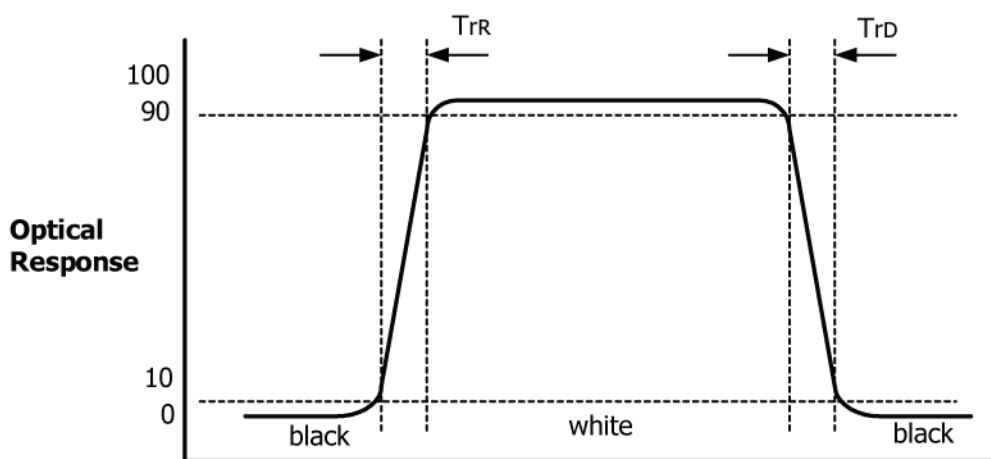

[FIG 7] Response Time

Sunlight Readable LCDs With Optical Bonding + Touch Integration

Specification

Color shift is defined as the following test pattern and color.

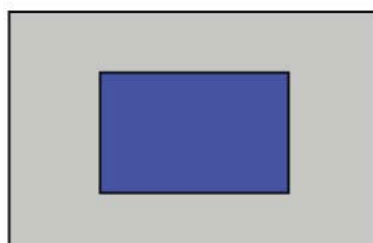

25% Box size

[FIG 8] Test Pattern

Average RGB values in Bruce RGB for Macbeth Chart

	Dark skin	Light skin	Blue sky	Foliage	Blue flower	Bluish green
R	98	206	85	77	129	114
G	56	142	112	102	118	199
B	45	123	161	46	185	178
	Orange	Purplish blue	Moderate red	Purple	Yellow green	Orange yellow
R	219	56	211	76	160	230
G	104	69	67	39	193	162
B	24	174	87	86	58	29
	Blue	Green	Red	Yellow	Magenta	cyan
R	26	72	197	241	207	35
G	32	148	27	212	62	126
B	145	65	37	36	151	172
	White	Neutral 8	Neutral 6.5	Neutral 5	Neutral 3.5	black
R	240	206	155	110	63	22
G	240	206	155	110	63	22
B	240	206	155	110	63	22

Sunlight Readable LCDs With Optical Bonding + Touch Integration

Specification

Dimension of viewing angle range.

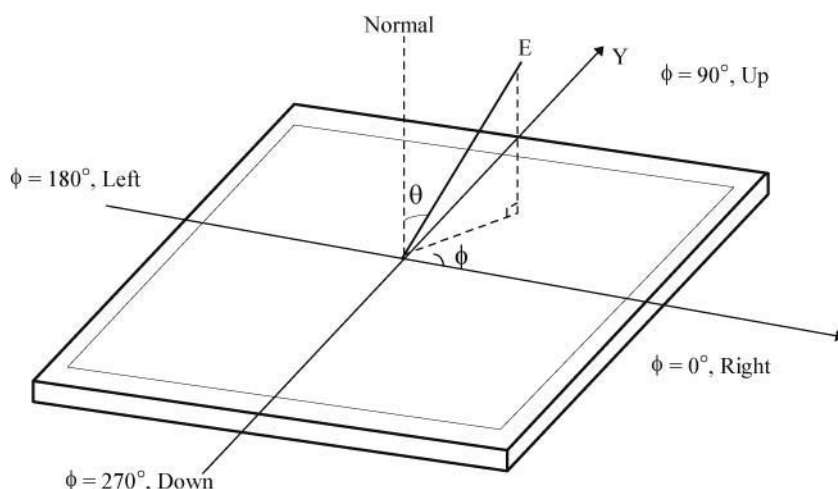

[FIG 9] Viewing angle

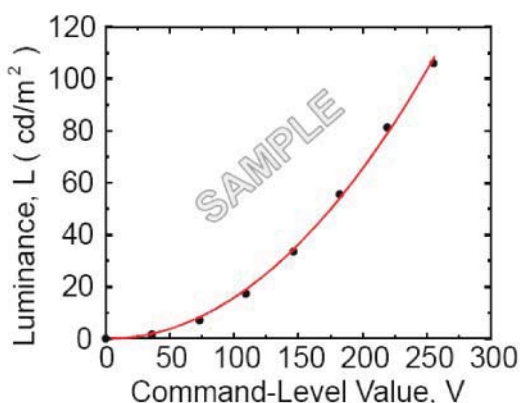

[FIG 10] Sample Luminance vs. gray scale (using a 256 bit gray scale)

$$L = aV^r + L_b$$

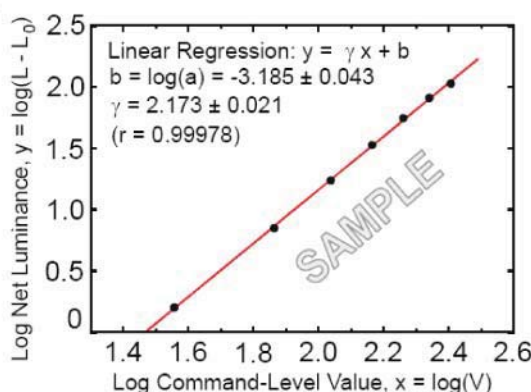

[FIG 11] Sample Log-log plot of luminance vs. gray scale

$$\log(L - L_b) = r \log(V) + \log(a)$$

Here the Parameter α and γ relate the signal level V to the luminance L .

The GAMMA we calculate from the log-log representation (FIG. 11)

Sunlight Readable LCDs With Optical Bonding + Touch Integration

Specification

Table 9. Gray Scale Specification

Gray Level	Relative Luminance [%] (Typ.)
0	0.10
31	1.08
63	4.71
95	11.5
127	21.7
159	35.5
191	53.1
223	74.5
255	100

5. Mechanical Characteristics

The contents provide general mechanical characteristics. In addition the figures in the next page are detailed mechanical drawing of the LCD.

Outline Dimension	Horizontal	495.6mm
	Vertical	305.25mm
	Depth	15.8mm
Bezel Area	Horizontal	479.84mm
	Vertical	272.32mm
Active Display Area	Horizontal	475.2mm
	Vertical	267.3mm
Weight	2300g (Typ.)	
Surface Treatment	Hard coating(2H) Glare, Low Reflection treatment of the front polarizer	

Notes : Please refer to a mechanic drawing in terms of tolerance at the next page.

Sunlight Readable LCDs With Optical Bonding + Touch Integration

Specification

<FRONT VIEW>

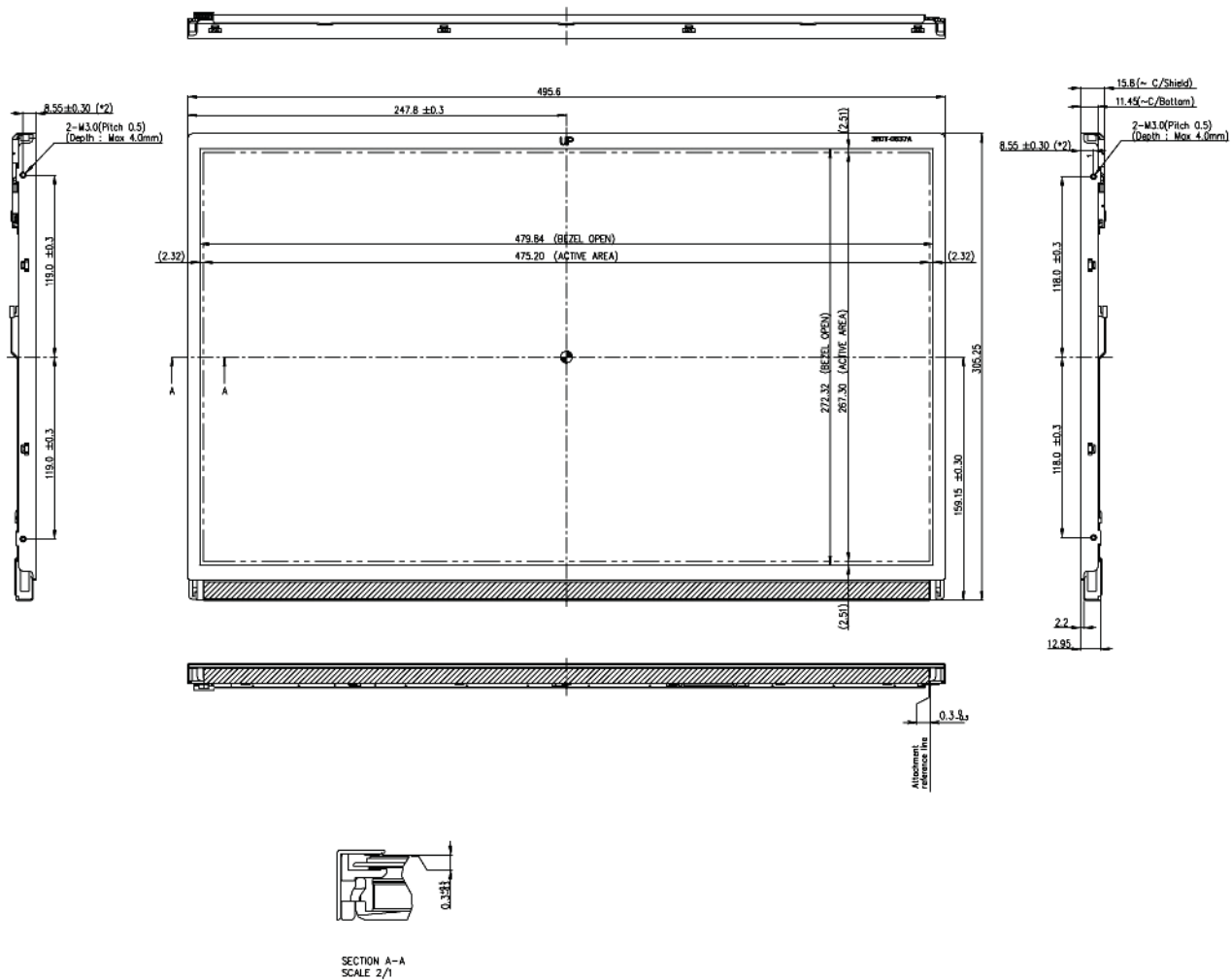

Sunlight Readable LCDs With Optical Bonding + Touch Integration

Specification

<REAR VIEW>

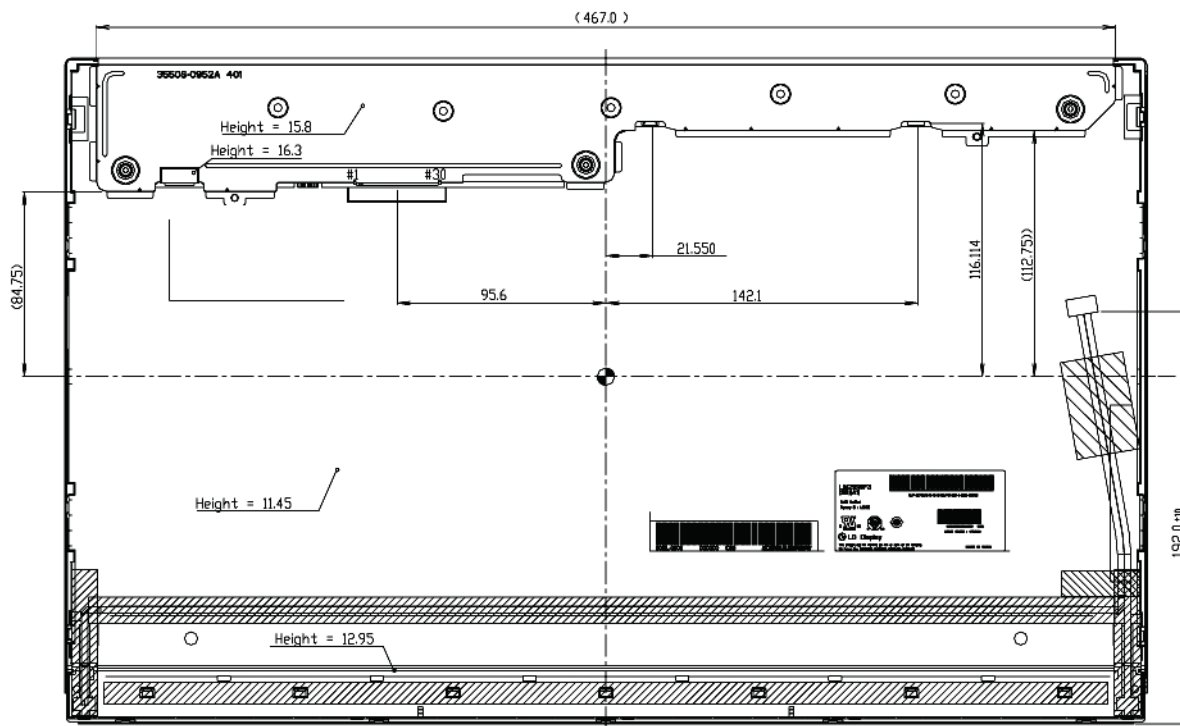

Notes

1. Unspecified tolerances are to be ± 0.5 mm.
2. Tilt and partial disposition tolerance of display area are following.
 - (1) Y-direction : $A+B < 11.0$ mm
 - (2) X-direction : $C+D < 11.0$ mm

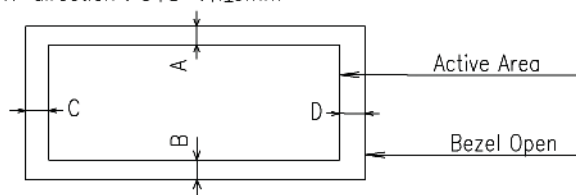

3. Unspecified contents have to be discussed with designer
4. Both backlight wires and contraction tubes are excluded from outline dimensions.
5. Torque Spec of User Mounting : 7.0 ~ 8.0kgf cm
6. LCM Weight : 2.3kg (Typ.) , 2.4kg (Max.)
7. The ass'y should have no defect in appearance.
8. LCM Flatness spec : Max 0.5mm
 - Measuring method : The gap is less than 0.5 from the flat surface plate to front side.

Sunlight Readable LCDs With Optical Bonding + Touch Integration

Specification

6. Reliability

Environment test condition

No	Test Item	Condition
1	High temperature storage test	Ta= 60°C 240h
2	Low temperature storage test	Ta= -20°C 240h
3	High temperature operation test	Ta= 50°C 50%RH 240h
4	Low temperature operation test	Ta= 0°C 240h
5	Vibration test (non-operating)	Wave form : random Vibration level : 1.0G RMS Bandwidth : 10-300Hz Duration : X,Y,Z, 20 min One time each direction
6	Shock test (non-operating)	Shock level : 120G Waveform : half sine wave, 2ms Direction : ±X, ±Y, ±Z One time each direction
7	Humidity condition Operation	Ta= 40 °C ,90%RH
8	Altitude storage / shipment	0 - 40,000 feet(12,192m)

Sunlight Readable LCDs With Optical Bonding + Touch Integration

Specification

7. International Standards

7-1. Safety

- a) UL 60950-1, Second Edition, Underwriters Laboratories Inc.
Information Technology Equipment - Safety - Part 1 : General Requirements.
- b) CAN/CSA C22.2 No.60950-1-07, Second Edition, Canadian Standards Association.
Information Technology Equipment - Safety - Part 1 : General Requirements.
- c) EN 60950-1:2006 + A11:2009, European Committee for Electrotechnical Standardization(CENELEC).
Information Technology Equipment - Safety - Part 1 : General Requirements.
- d) IEC 60950-1:2005, Second Edition, The International Electrotechnical Commission (IEC).
Information Technology Equipment - Safety - Part 1 : General Requirements.
(Including report of IEC60825-1:2001 clause 8 and clause 9)

Notes

- 1. Laser (LED Backlight) Information

Class 1 LED Product IEC60825-1 : 2001 Embedded LED Power (Class 1)
--

7-2. EMC

- a) ANSI C63.4 "American National Standard for Methods of Measurement of Radio-Noise Emissions from Low-Voltage Electrical and Electronic Equipment in the Range of 9 kHz to 40 GHz." American National Standards Institute (ANSI), 2003.
- b) CISPR 22 "Information technology equipment – Radio disturbance characteristics – Limit and methods of measurement." International Special Committee on Radio Interference (CISPR), 2005.
- c) CISPR 13 "Sound and television broadcast receivers and associated equipment – Radio disturbance characteristics – Limits and method of measurement." International Special Committee on Radio Interference (CISPR), 2006.

7-3. Environment

- a) RoHS, Directive 2002/95/EC of the European Parliament and of the council of 27 January 2003

Sunlight Readable LCDs With Optical Bonding + Touch Integration

Specification

8. Packing

8-1. Designation of Lot Mark

a) Lot Mark

A	B	C	D	E	F	G	H	I	J	K	L	M
---	---	---	---	---	---	---	---	---	---	---	---	---

A,B,C : SIZE(INCH)
 E : MONTH

D : YEAR
 F ~ M : SERIAL NO.

Note

1. YEAR

Year	2001	2002	2003	2004	2005	2006	2007	2008	2009	2010
Mark	1	2	3	4	5	6	7	8	9	0

2. MONTH

Month	Jan	Feb	Mar	Apr	May	Jun	Jul	Aug	Sep	Oct	Nov	Dec
Mark	1	2	3	4	5	6	7	8	9	A	B	C

b) Location of Lot Mark

Serial No. is printed on the label. The label is attached to the backside of the LCD module.
 This is subject to change without prior notice.

8-2. Packing Form

a) Package quantity in one box : 7pcs

b) Box Size : 360 * 310 * 562 (mm)

Sunlight Readable LCDs With Optical Bonding + Touch Integration

Specification

9. PRECAUTIONS

Please pay attention to the followings when you use this TFT LCD module.

9-1. MOUNTING PRECAUTIONS

- (1) You must mount a module using holes arranged in four corners or four sides.
- (2) You should consider the mounting structure so that uneven force (ex. Twisted stress) is not applied to the module. And the case on which a module is mounted should have sufficient strength so that external force is not transmitted directly to the module.
- (3) Please attach the surface transparent protective plate to the surface in order to protect the polarizer. Transparent protective plate should have sufficient strength in order to resist external force.
- (4) You should adopt radiation structure to satisfy the temperature specification.
- (5) Acetic acid type and chlorine type materials for the cover case are not desirable because the former generates corrosive gas of attacking the polarizer at high temperature and the latter causes circuit break by electro-chemical reaction.
- (6) Do not touch, push or rub the exposed polarizers with glass, tweezers or anything harder than HB pencil lead. And please do not rub with dust clothes with chemical treatment. Do not touch the surface of polarizer for bare hand or greasy cloth. (Some cosmetics are detrimental to the polarizer.)
- (7) When the surface becomes dusty, please wipe gently with absorbent cotton or other soft materials like chamois soaks with petroleum benzene. Normal-hexane is recommended for cleaning the adhesives used to attach front / rear polarizers. Do not use acetone, toluene and alcohol because they cause chemical damage to the polarizer.
- (8) Wipe off saliva or water drops as soon as possible. Their long time contact with polarizer causes deformations and color fading.
- (9) Do not open the case because inside circuits do not have sufficient strength.

9-2. OPERATING PRECAUTIONS

- (1) The spike noise causes the mis-operation of circuits. It should be lower than following voltage :
 $V = \pm 200\text{mV}$ (Over and under shoot voltage)
- (2) Response time depends on the temperature. (In lower temperature, it becomes longer.)
- (3) Brightness depends on the temperature. (In higher temperature, it becomes lower.)
And in lower temperature, response time (required time that brightness is stable after turned on) becomes longer.
- (4) Be careful for condensation at sudden temperature change. Condensation makes damage to polarizer or electrical contacted parts. And after fading condensation, smear or spot will occur.
- (5) When fixed patterns are displayed for a long time, remnant image is likely to occur.
- (6) Module has high frequency circuits. Sufficient suppression to the electromagnetic interference shall be done by system manufacturers. Grounding and shielding methods may be important to minimize the interference.
- (7) Please do not give any mechanical and/or acoustical impact to LCM. Otherwise, LCM can't be operated its full characteristics perfectly.
- (8) A screw which is fastened up the steels should be a machine screw.
(if not, it causes metallic foreign material and deal LCM a fatal blow)
- (9) Please do not set LCD on its edge.

Sunlight Readable LCDs With Optical Bonding + Touch Integration

Specification

9-3. ELECTROSTATIC DISCHARGE CONTROL

Since a module is composed of electronic circuits, it is not strong to electrostatic discharge. Make certain that treatment persons are connected to ground through wrist band etc. And don't touch interface pin directly.

9-4. PRECAUTIONS FOR STRONG LIGHT EXPOSURE

Strong light exposure causes degradation of polarizer and color filter.

9-5. STORAGE

When storing modules as spares for a long time, the following precautions are necessary.

- (1) Store them in a dark place. Do not expose the module to sunlight or fluorescent light. Keep the temperature between 5°C and 35°C at normal humidity.
- (2) The polarizer surface should not come in contact with any other object.
It is recommended that they be stored in the container in which they were shipped.

9-6. HANDLING PRECAUTIONS FOR PROTECTION FILM

- (1) The protection film is attached to the bezel with a small masking tape.
When the protection film is peeled off, static electricity is generated between the film and polarizer.
This should be peeled off slowly and carefully by people who are electrically grounded and with well ion-blown equipment or in such a condition, etc.
- (2) When the module with protection film attached is stored for a long time, sometimes there remains a very small amount of glue still on the bezel after the protection film is peeled off.
- (3) You can remove the glue easily. When the glue remains on the bezel surface or its vestige is recognized, please wipe them off with absorbent cotton waste or other soft material like chamois soaked with normal-hexane.

Sunlight Readable LCDs With Optical Bonding + Touch Integration

Specification

10. EDID DATA FOR DP215FHDI

10-1. EDID Data

DP215FHDI EDID DATA (1920X1080 @ 60Hz)

Byte# (decimal)	Byte# (HEX)	Field Name and Comments	Value (HEX)	Value (binary)	Value (DEC)		
0	00	Header	00	00000000	0	Header	
1	01	Header	FF	11111111	255		
2	02	Header	FF	11111111	255		
3	03	Header	FF	11111111	255		
4	04	Header	FF	11111111	255		
5	05	Header	FF	11111111	255		
6	06	Header	FF	11111111	255		
7	07	Header	00	00000000	0		
8	08	EISA manufacture code (3 Character ID) APP	06	00000110	6	product ID for LM215WF3-SDA1 = 0x9CDD Vender/ Product ID	
9	09	EISA manufacture code (Compressed ASC II)	10	00010000	16		
10	0A	Panel Supplier Reserved - Product Code 9CDDh	DD	11011101	221		
11	0B	(Hex, LSB first)	9C	10011100	156		
12	0C	32-bit serial #	00	00000000	0		
13	0D		00	00000000	0		
14	0E		00	00000000	0		
15	0F		00	00000000	0		
16	10	Week of Manufacture	0A	00001010	10		10th weeks
17	11	Year of Manufacture 2010 years	14	00010100	20		
18	12	EDID structure version # = 1	01	00000001	1	EDID Version/ Revision	
19	13	EDID revision # = 4	04	00000100	4		
20	14	Video input Definition = DisplayPort 8bit	A5	10100101	165	Display Parameter	
21	15	Max H image size (Rounded cm) = 48 cm	30	00110000	48		
22	16	Max V image size (Rounded cm) = 27 cm	1B	00011011	27		
23	17	Display gamma = (gamma*100)-100 = Example:(2.2*100)-100=120	78	01111000	120		
24	18	Feature Support [Display Power Management(DPM) : No_standby, No_suspend, Active Off/Very Low Power., Display Color Type : Monochrome or Grayscale display., Other Feature Support Flags : No_sRGB, Preferred Timing Mode, No_Display is continuous frequency (Multi-mode_Base EDID and Extension Block).]	22	00100010	34	Color Characteristic	
25	19	Red/Green Low Bits (RxRy/GxGy)	6F	01101111	111		
26	1A	Blue/White Low Bits (BxBY/WxWy)	B1	10110001	177		
27	1B	Red X Rx = 0.653	A7	10100111	167		
28	1C	Red Y Ry = 0.334	55	01010101	85		
29	1D	Green X Gx = 0.300	4C	01001100	76		
30	1E	Green Y Gy = 0.620	9E	10011110	158		
31	1F	Blue X Bx = 0.146	25	00100101	37		
32	20	Blue Y By = 0.050	0C	00001100	12		
33	21	White X Wx = 0.313	50	01010000	80		
34	22	White Y Wy = 0.329	54	01010100	84		
35	23	Established timing 1 (00h if not used)	00	00000000	0	Established Timings	
36	24	Established timing 2 (00h if not used)	00	00000000	0		
37	25	Manufacturer's timings	00	00000000	0	Standard Timing ID	
38	26	Standard timing ID1 (01h if not used)	01	00000001	1		
39	27	Standard timing ID1 (01h if not used)	01	00000001	1		
40	28	Standard timing ID2 (01h if not used)	01	00000001	1		
41	29	Standard timing ID2 (01h if not used)	01	00000001	1		
42	2A	Standard timing ID3 (01h if not used)	01	00000001	1		
43	2B	Standard timing ID3 (01h if not used)	01	00000001	1		
44	2C	Standard timing ID4 (01h if not used)	01	00000001	1		
45	2D	Standard timing ID4 (01h if not used)	01	00000001	1		
46	2E	Standard timing ID5 (01h if not used)	01	00000001	1		
47	2F	Standard timing ID5 (01h if not used)	01	00000001	1		
48	30	Standard timing ID6 (01h if not used)	01	00000001	1		
49	31	Standard timing ID6 (01h if not used)	01	00000001	1		
50	32	Standard timing ID7 (01h if not used)	01	00000001	1		
51	33	Standard timing ID7 (01h if not used)	01	00000001	1		
52	34	Standard timing ID8 (01h if not used)	01	00000001	1		
53	35	Standard timing ID8 (01h if not used)	01	00000001	1		

Sunlight Readable LCDs With Optical Bonding + Touch Integration

Specification

54	36	Detailed timing/monitor	1A	00011010	26	
55	37	Pixel Clock = 138.5 MHz	36	00110110	54	
56	38	Hor active= 1920 pixels	80	10000000	128	
57	39	Hor blanking= 160 pixels	A0	10100000	160	
58	3A		70	01110000	112	
59	3B	Vertical active= 1080 lines	38	00111000	56	
60	3C	Vertical blanking= 31 lines	1F	00011111	31	Detailed Timing Description #1
61	3D		40	01000000	64	
62	3E	H sync. Offset= 48 pixels	30	00110000	48	
63	3F	H sync. Width= 32 pixels	20	00100000	32	
64	40	V sync. Offset=3 lines, V sync. Width= 5 lines	35	00110101	53	
65	41		00	00000000	0	
66	42	H image size= 475 mm	DB	11011011	219	
67	43	V image size = 267 mm	0B	00001011	11	
68	44		11	00010001	17	
69	45	No Horizontal Border	00	00000000	0	
70	46	No Vertical Border	00	00000000	0	
71	47	Non-Interface, Normal display, no stereo, Digital Separate Vsync_NEG, Hsync	1A	00011010	26	
72	48	Manufacturer Specific data	00	00000000	0	
73	49		00	00000000	0	
74	4A		00	00000000	0	
75	4B	Apple extension, DisplayPort digital interface format	02	00000010	2	
76	4C		01	00000001	1	
77	4D	AMD GPU Vendor ID	06	00000110	6	
78	4E	display prefers 10 bits per color component in the color pipeline	10	00010000	16	
79	4F		01	00000001	1	Detailed Timing Description #2
80	50	GPU spatial dithering if supported	0A	00001010	10	
81	51	non-specified GPU Vendor ID	01	00000001	1	
82	52	use native GPU pixel depth	00	00000000	0	
83	53	No GPU dithering, if GPU pipe depth != DisplayPort	00	00000000	0	
84	54	panel depth then truncate	00	00000000	0	
85	55	non-specified GPU Vendor ID	00	00000000	0	
86	56	use native GPU pixel depth	00	00000000	0	
87	57	No GPU dithering, if GPU pipe depth != DisplayPort	00	00000000	0	
88	58	panel depth then truncate	00	00000000	0	
89	59		00	00000000	0	
90	5A	Detailed timing/monitor	00	00000000	0	
91	5B	descriptor #3	00	00000000	0	
92	5C		00	00000000	0	
93	5D		FC	11111100	252	
94	5E		00	00000000	0	
95	5F	C	43	01000011	67	
96	60	o	6F	01101111	111	
97	61	l	6C	01101100	108	
98	62	o	6F	01101111	111	
99	63	r	72	01110010	114	
100	64		20	00100000	32	
101	65	L	4C	01001100	76	
102	66	C	43	01000011	67	
103	67	D	44	01000100	68	
104	68		0A	00001010	10	
105	69		20	00100000	32	
106	6A		20	00100000	32	
107	6B		20	00100000	32	Ascii Data String:
108	6C	Detailed timing/monitor	00	00000000	0	
109	6D	descriptor #4	00	00000000	0	
110	6E	Color LCD	00	00000000	0	
111	6F		00	00000000	0	
112	70		00	00000000	0	
113	71		00	00000000	0	
114	72		00	00000000	0	
115	73		00	00000000	0	
116	74		00	00000000	0	Detailed Timing Description #4
117	75		00	00000000	0	
118	76		00	00000000	0	
119	77		00	00000000	0	Monitor Name: Color LCD
120	78		00	00000000	0	
121	79		00	00000000	0	
122	7A		00	00000000	0	
123	7B		00	00000000	0	
124	7C		00	00000000	0	
125	7D		00	00000000	0	
126	7E	Extension Flag = 01	00	00000000	0	Extension Flag
127	7F	Checksum	55	01010101	85	Checksum

Sunlight Readable LCDs With Optical Bonding + Touch Integration



DP215FHDI

Specification

128	80	00	00000000	0
129	81	00	00000000	0
130	82	00	00000000	0
131	83	00	00000000	0
132	84	00	00000000	0
133	85	0	00000000	0
134	86	0	00000000	0
135	87	0	00000000	0
136	88	0	00000000	0
137	89	0	00000000	0
138	8A	0	00000000	0
139	8B	00	00000000	0
140	8C	0	00000000	0
141	8D	0	00000000	0
142	8E	00	00000000	0
143	8F	00	00000000	0
144	90	00	00000000	0
145	91	00	00000000	0
146	92	00	00000000	0
147	93	00	00000000	0
148	94	00	00000000	0
149	95	00	00000000	0
150	96	00	00000000	0
151	97	00	00000000	0
152	98	00	00000000	0
153	99	00	00000000	0
154	9A	00	00000000	0
155	9B	00	00000000	0
156	9C	00	00000000	0
157	9D	00	00000000	0
158	9E	00	00000000	0
159	9F	00	00000000	0
160	A0	00	00000000	0
161	A1	00	00000000	0
162	A2	00	00000000	0
163	A3	00	00000000	0
164	A4	00	00000000	0
165	A5	00	00000000	0
166	A6	00	00000000	0
167	A7	00	00000000	0
168	A8	00	00000000	0
169	A9	00	00000000	0
170	AA	00	00000000	0
171	AB	00	00000000	0
172	AC	00	00000000	0
173	AD	00	00000000	0
174	AE	00	00000000	0
175	AF	00	00000000	0
176	B0	00	00000000	0
177	B1	00	00000000	0
178	B2	00	00000000	0
179	B3	00	00000000	0
180	B4	00	00000000	0
181	B5	00	00000000	0
182	B6	00	00000000	0
183	B7	00	00000000	0
184	B8	00	00000000	0
185	B9	00	00000000	0
186	BA	00	00000000	0
187	BB	00	00000000	0
188	BC	00	00000000	0
189	BD	00	00000000	0
190	BE	00	00000000	0
191	BF	00	00000000	0
192	C0	00	00000000	0
193	C1	00	00000000	0
194	C2	00	00000000	0
195	C3	00	00000000	0
196	C4	00	00000000	0
197	C5	00	00000000	0
198	C6	00	00000000	0
199	C7	00	00000000	0
200	C8	00	00000000	0
201	C9	00	00000000	0
202	CA	00	00000000	0
203	CB	00	00000000	0
204	CC	00	00000000	0
205	CD	00	00000000	0
206	CE	00	00000000	0
207	CF	00	00000000	0
208	D0	00	00000000	0
209	D1	00	00000000	0
210	D2	00	00000000	0
211	D3	00	00000000	0
212	D4	00	00000000	0
213	D5	00	00000000	0
214	D6	00	00000000	0
215	D7	00	00000000	0
216	D8	00	00000000	0
217	D9	00	00000000	0
218	DA	00	00000000	0
219	DB	00	00000000	0
220	DC	00	00000000	0
221	DD	00	00000000	0
222	DE	00	00000000	0
223	DF	00	00000000	0
224	E0	00	00000000	0
225	E1	00	00000000	0

Sunlight Readable LCDs With Optical Bonding + Touch Integration

Specification

226	E2		00	00000000	0
227	E3		00	00000000	0
228	E4		00	00000000	0
229	E5		00	00000000	0
230	E6		00	00000000	0
231	E7		00	00000000	0
232	E8		00	00000000	0
233	E9		00	00000000	0
234	EA		00	00000000	0
235	EB		00	00000000	0
236	EC		00	00000000	0
237	ED		00	00000000	0
238	EE		00	00000000	0
239	EF		00	00000000	0
240	F0		00	00000000	0
241	F1		00	00000000	0
242	F2		00	00000000	0
243	F3		00	00000000	0
244	F4		00	00000000	0
245	F5		00	00000000	0
246	F6		00	00000000	0
247	F7		00	00000000	0
248	F8		00	00000000	0
249	F9		00	00000000	0
250	FA		00	00000000	0
251	FB		00	00000000	0
252	FC		00	00000000	0
253	FD		00	00000000	0
254	FE		00	00000000	0
255	FF	Checksum	00	00000000	

10-2. EDID DATA READ/WRITE PROTOCOL

10-2-1. READ Operation

<Start><Slave Address, RW=0><Byte Address><Start><Slave Address, RW=1><Data><Stop>

10-2-2. WRITE Operation

<Start><Slave Address, RW=0><Byte Address><Data><Stop>

- Device Address (Slave Address)

Type	Device (Slave) Address							Hex	
IS24C02B	1	0	1	0	0	0	0	RW	0xA0 + RW

- Byte Address

Byte Address	
Decimal	0 ~ 127
Hex	0x00 ~ 0x7F

Sunlight Readable LCDs With Optical Bonding + Touch Integration