

Specification

DP**DOPOINT****720****Size****FHD****Pixel**

A:640*480

B:800*480

C:800*600

D:1024*600

E:1024*768

F:1280*768

G:1280*800

H:1280*1024

HD:1366*768

J:1600*1200

K:1920*1200

FHD:1920*1080

I**Mode**

T: TN

I: IPS

Product Order Number	Description
DP720FHDI-XXXX	<ul style="list-style-type: none"> • IPS Normally Black • 0°C to +50°C Operating Temperature • Viewing Angle L/R/U/D - 89/89/89/89 • Luminance – 2000 cd/m² • Contrast Ratio – 1100:1
DP720FHDI-TXXX	Resistive + Capacitive Touch by Optical Bonding
DP720FHDI-HXXX	Extended temp (Add Heater by Optical Bonding) -40°C to +80°C Operating Temperature
DP720FHDI-EXXX	Integrated Front Optical EMI Filter by Optical Bonding
DP720FHDI-ARAG	Anti-Reflective + Anti-Glare Surface Treatment
DP720FHDI-NVIS	Integrated NVIS Optical Filter

Sunlight Readable LCDs With Optical Bonding + Touch Integration

Specification

1. General Description

The DP720FHDI is a Color Active Matrix Liquid Crystal Display with an integral Light Emitting Diode (LED) backlight system. The matrix employs a-Si Thin Film Transistor as the active element. It is a transmissive type display operating in the normally black mode. It has a 72.07 inch diagonally measured active display area with WUXGA resolution (1080 vertical by 1920 horizontal pixel array). Each pixel is divided into Red, Green and Blue sub-pixels or dots which are arranged in vertical stripes. Gray scale or the luminance of the sub-pixel color is determined with a 8-bit gray scale signal for each dot. Therefore, it can present a palette of more than 16.7 Million colors. It is intended to support Public Display where high brightness, super wide viewing angle, high color gamut, high color depth and fast response time are important.

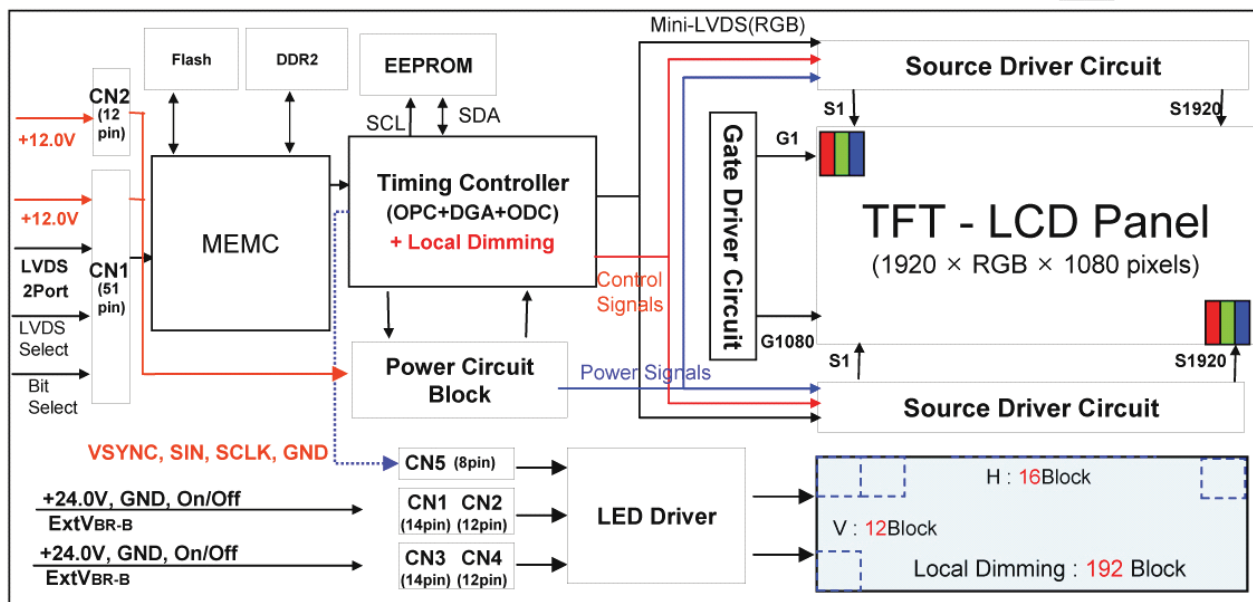

General Features

Active Screen Size	72.07 inches(1830.616mm) diagonal
Outline Dimension	1666.0(H) x 968.0 (V) x 60.0 mm(D) (Typ.)
Pixel Pitch	0.831 mm x 0.831 mm
Pixel Format	1920 horiz. by 1080 vert. Pixels, RGB stripe arrangement
Color Depth	8bit , 16.7Million colors
Luminance, White	2000 cd/m ² (Center 1point ,Typ.)
Viewing Angle (CR>10)	Viewing angle free (R/L 178 (Min.), U/D 178 (Min.))
Power Consumption	Total 501.9W(TBD) (Typ.) (Logic=13.2W(TBD), LED Driver =488.7W
Weight	37Kg (Typ.)
Display Mode	Transmissive mode, Normally black
Surface Treatment	Hard coating(3H), Anti-reflection treatment of the front polarizer (Reflectance : < 2%)
Possible Display Type	Landscape and Portrait Enabled

Sunlight Readable LCDs With Optical Bonding + Touch Integration

Specification

2. Absolute Maximum Ratings

The following items are maximum values which, if exceeded, may cause faulty operation or damage to the LCD module.

Table 1. ABSOLUTE MAXIMUM RATINGS

Parameter		Symbol	Value		Unit	Note
			Min	Max		
Power Input Voltage	LCD Circuit	V _{LCD}	-0.3	+14.0	V _{DC}	
	Driver	V _{BL}	-0.3	+ 27.0	V _{DC}	
Driver Control Voltage	ON/OFF	V _{OFF} / V _{ON}	-0.3	+5.5	V _{DC}	
	Brightness	EXTVBR-B	0.0	+5.5	V _{DC}	
T-Con Option Selection Voltage		V _{LOGIC}	-0.3	+4.0	V _{DC}	1
Operating Temperature		T _{OP}	0	+50	°C	2
Storage Temperature		T _{ST}	-20	+60	°C	
Operating Ambient Humidity		H _{OP}	10	90	%RH	2
Storage Humidity		H _{ST}	10	90	%RH	

Note: 1. Ambient temperature condition ($T_a = 25 \pm 2 \text{ }^\circ\text{C}$)

2. Temperature and relative humidity range are shown in the figure below. Wet bulb temperature should be Max 39 °C and no condensation of water.

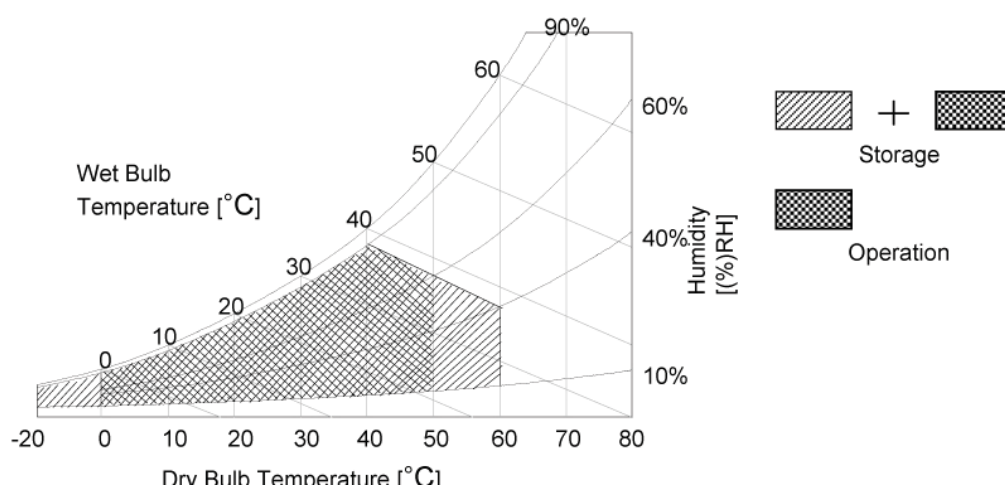

Sunlight Readable LCDs With Optical Bonding + Touch Integration

Specification

3. Electrical Specifications

3-1. Electrical Characteristics

It requires two power inputs. One is employed to power for the LCD circuit. The other is used for the LED backlight and LED Driver circuit.

Table 2. ELECTRICAL CHARACTERISTICS

Parameter	Symbol	Value			Unit	Note
		Min	Typ	Max		
Circuit :						
Power Input Voltage	V _{LCD}	10.8	12.0	13.2	V _{DC}	
Power Input Current	I _{LCD}	924(TBD)	1320 (TBD)	1716(TBD)	mA	1
		2240(TBD)	3200(TBD)	4160(TBD)	mA	2
Power Consumption	P _{LCD}	-	15.8(TBD)	20.6(TBD)	Watt	1
Rush current	I _{RUSH}	-	-	15.0	A	3

Note 1. The specified current and power consumption are under the V_{LCD}=12.0V, Ta=25 ± 2°C, f_V=240Hz condition whereas mosaic pattern(8 x 6) is displayed and f_V is the frame frequency.

2. The current is specified at the maximum current pattern.

3. The duration of rush current is about 2ms and rising time of power input is 0.5ms (min.).

White : 255 Gray

Black : 0 Gray

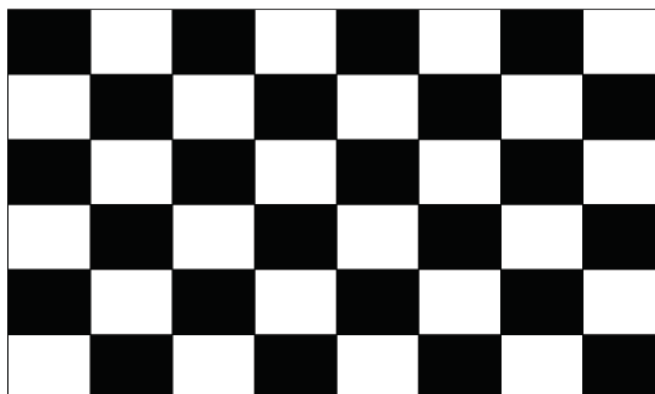

Mosaic Pattern(8 x 6)

Sunlight Readable LCDs With Optical Bonding + Touch Integration

Specification

Table 3. ELECTRICAL CHARACTERISTICS (Continue)

Parameter		Symbol	Values			Unit	Notes	
			Min	Typ	Max			
LED Driver :								
Power Supply Input Voltage		VBL	21.6	24	26.4	Vdc	1	
Power Supply Input Current		IBL_A	-	20.3	21.7	A	Ext VBR-B = 100%	
Power Supply Input Current (In-Rush)		Irush	-	-	27.3	A	VBL = 22.8V Ext VBR-B = 100% 4	
Power Consumption		PBL	-	488.7	519.3	W	Ext VBR-B = 100%	
Input Voltage for Control System Signals	On/Off	On	V on	2.5	-	5.0	Vdc	
		Off	V off	-0.3	0.0	0.5	Vdc	
	Brightness Adjust		ExtVBR-B	10	-	100	%	On Duty
	PWM Frequency for NTSC & PAL		PAL		200		Hz	3
			NTSC		240		Hz	3
	Pulse Duty Level (PWM)		High Level	2.5	-	5.0	Vdc	HIGH : on duty LOW : off duty
			Low Level	0.0	-	0.5	Vdc	
	VSYNC, SIN, SCLK, Reverse (Local Dimming)		High Level	2.7	3.3	3.6	Vdc	
Low Level			-0.3	0.0	0.4	Vdc		
LED :								
Life Time			40,000			Hrs	2	

Notes :

1. Electrical characteristics are determined after the unit has been 'ON' and stable for approximately 60 minutes at 25±2°C. The specified current and power consumption are under the typical supply Input voltage 24V and VBR (ExtVBR-B : 100%), it is total power consumption.
2. The life time(MTTF) is determined as the time which luminance of the LED is 50% compared to that of initial value at the typical LED current (ExtVBR-B :100%) on condition of continuous operating in LCM state at 25±2°C.
3. LGD recommend that the PWM freq. is synchronized with One time harmonic of Vsync signal of system. Though PWM frequency is over 252Hz(Max), function of LED Driver is not affected.
4. The duration of rush current is about 10ms.
5. Even though inrush current is over the specified value, there is no problem if I²T spec of fuse is satisfied.

Sunlight Readable LCDs With Optical Bonding + Touch Integration

Specification

3-2. Interface Connections

This LCD module employs three kinds of interface connection, 51-pin connector are used for the module electronics and 14-pin connector is used for the integral backlight system.

3-2-1. LCD Module

- LCD Connector : FI-R51S-HF(manufactured by JAE) or compatible (CN1) Refer to below and next Page table
- Mating Connector : FI-R51HL(JAE) or compatible

Table 4-1. MODULE CONNECTOR(CN1) PIN CONFIGURATION

No	Symbol	Description	No	Symbol	Description
1	NC	No Connection (Reserved for LGD)	27	Bit Select	NC (8Bit only)
2	NC	No Connection (Reserved for LGD)	28	R2AN	SECOND LVDS Receiver Signal (A-)
3	NC	No Connection (Reserved for LGD)	29	R2AP	SECOND LVDS Receiver Signal (A+)
4	NC	No Connection (Reserved for LGD)	30	R2BN	SECOND LVDS Receiver Signal (B-)
5	NC	No Connection (Reserved for LGD)	31	R2BP	SECOND LVDS Receiver Signal (B+)
6	NC	No Connection (Reserved for LGD)	32	R2CN	SECOND LVDS Receiver Signal (C-)
7	LVDS Select	NC ('H' =JEIDA , Fix)	33	R2CP	SECOND LVDS Receiver Signal (C+)
8	NC	No Connection (Reserved for LGD)	34	GND	Ground
9	NC	No Connection (Reserved for LGD)	35	R2CLKN	SECOND LVDS Receiver Clock Signal(-)
10	L-DIM Enable	H= Enable (Fix)	36	R2CLKP	SECOND LVDS Receiver Clock Signal(+)
11	GND	Ground	37	GND	Ground
12	R1AN	FIRST LVDS Receiver Signal (A-)	38	R2DN	SECOND LVDS Receiver Signal (D-)
13	R1AP	FIRST LVDS Receiver Signal (A+)	39	R2DP	SECOND LVDS Receiver Signal (D+)
14	R1BN	FIRST LVDS Receiver Signal (B-)	40	R2EN	SECOND LVDS Receiver Signal (E-)
15	R1BP	FIRST LVDS Receiver Signal (B+)	41	R2EP	SECOND LVDS Receiver Signal (E+)
16	R1CN	FIRST LVDS Receiver Signal (C-)	42	GND	Ground
17	R1CP	FIRST LVDS Receiver Signal (C+)	43	GND	Ground
18	GND	Ground	44	GND	Ground
19	R1CLKN	FIRST LVDS Receiver Clock Signal(-)	45	GND	Ground
20	R1CLKP	FIRST LVDS Receiver Clock Signal(+)	46	GND	Ground
21	GND	Ground	47	NC	Don't Care
22	R1DN	FIRST LVDS Receiver Signal (D-)	48	VLCD	Power Supply +12.0V
23	R1DP	FIRST LVDS Receiver Signal (D+)	49	VLCD	Power Supply +12.0V
24	R1EN	FIRST LVDS Receiver Signal (E-)	50	VLCD	Power Supply +12.0V
25	R1EP	FIRST LVDS Receiver Signal (E+)	51	VLCD	Power Supply +12.0V
26	NC	No Connection	-	-	-

- Note**
1. All GND(ground) pins should be connected together to the LCD module's metal frame.
 2. All VLCD (power input) pins should be connected together.
 3. All Input levels of LVDS signals are based on the EIA 644 Standard.
 4. Specific pins(pin No. **#2,#3,#6,#9**) are used for internal data process of the LCD module. These pins should be no connection.
 5. Specific pin (pin No. **# 10**) are used for Local Dimming of the LCD module.
This Model is fixed Local Dimming ON
 6. It may be happened to Abnormal Display during the system interface signal is not.

Sunlight Readable LCDs With Optical Bonding + Touch Integration

Specification

3-2. Power Connector(CN2) Pin CONFIGURATION

Control CN2

- Power Connector : KN21-12P-2H (Hirose)
or Equivalent
- Mating Connector : 20022HS-12 or Equivalent

Table 4-2. MODULE CONNECTOR(CN2) PIN CONFIGURATION

Pin No	Symbol	Description	Note
1	VLCD	Power Supply +12.0V	
2	VLCD	Power Supply +12.0V	
3	VLCD	Power Supply +12.0V	
4	VLCD	Power Supply +12.0V	
5	VLCD	Power Supply +12.0V	
6	GND	Ground	
7	GND	Ground	
8	GND	Ground	
9	GND	Ground	
10	GND	Ground	
11	NC	No connection	
12	NC	No connection	

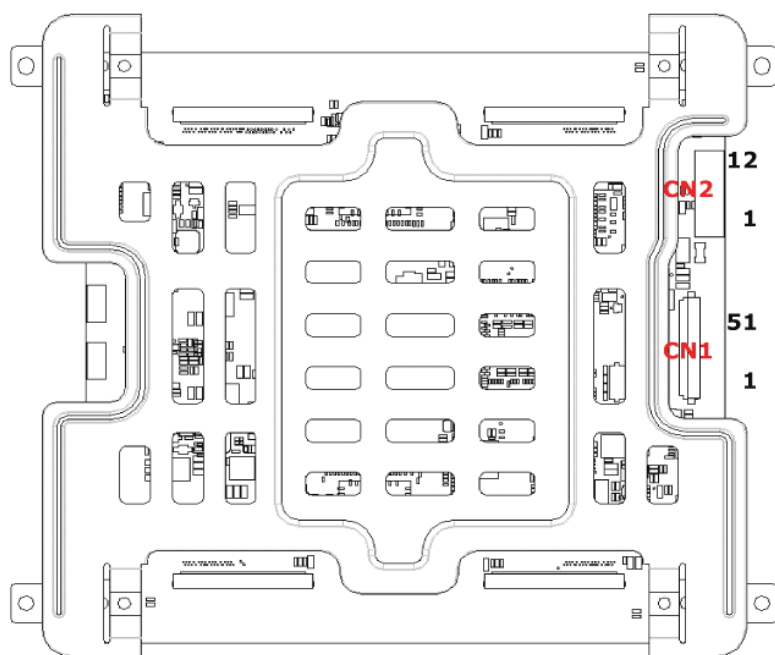

Part/No. : FI-RE51S-HF(JAE)
 Mating connector : FI-RE51HL
 (Manufactured by JAE) or compatible

Sunlight Readable LCDs With Optical Bonding + Touch Integration

Specification

3-2-2. Backlight Module

Board A(CN1002), Board B(CN2002)

- LED Driver Connector : 20022WR-14B1(Yeonho)

- Mating Connector : 20022HS-14

Board A(CN1001), Board B(CN2002)

- LED Driver Connector : 20022WR-12B1(Yeonho)

- Mating Connector : 20022HS-12

Table 5. LED DRIVER CONNECTOR PIN CONFIGURATION

Pin No	Symbol	Description	Board A (CN1002) Board B (CN2002)	Board A (CN1001) Board B (CN2001)	Note
1	VBL	Power Supply +24.0V	VBL	VBL	
2	VBL	Power Supply +24.0V	VBL	VBL	
3	VBL	Power Supply +24.0V	VBL	VBL	
4	VBL	Power Supply +24.0V	VBL	VBL	
5	VBL	Power Supply +24.0V	VBL	VBL	
6	GND	Backlight Ground	GND	GND	1
7	GND	Backlight Ground	GND	GND	
8	GND	Backlight Ground	GND	GND	
9	GND	Backlight Ground	GND	GND	
10	GND	Backlight Ground	GND	GND	
11	Status	Back Light Status	Back Light Status	Don't Care	2
12	VON/OFF	Backlight ON/OFF control	Backlight ON/OFF control	Don't Care	
13	EXTVBR-B	External PWM	EXTVBR-B		3
14	GND	Backlight Ground	GND		4

Notes : 1. GND should be connected to the LCD module's metal frame.

2. Normal : Low (under 0.7V) / Abnormal : High (upper 3.0V)

3. High : on duty / Low : off duty, Pin#13 can be opened. (if Pin #13 is open , EXTVBR-B is 100%)

4. #14 of Input CNT Must be Connected to Backlight Ground.

5. Each impedance of pin #12 and 13 is over TBD [KΩ] and over TBD [KΩ].

◆ Rear view of LCM

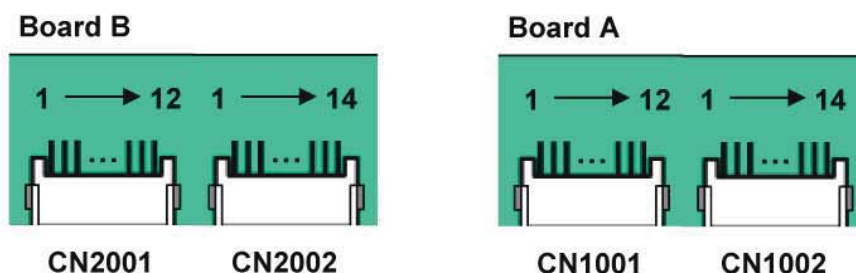

Sunlight Readable LCDs With Optical Bonding + Touch Integration

Specification

3-3. Signal Timing Specifications

Table 6 shows the signal timing required at the input of the LVDS transmitter. All of the interface signal timings should be satisfied with the following specification for normal operation.

Table 6-1. TIMING TABLE for NTSC (DE Only Mode)

ITEM		Symbol	NTSC/ATSC	DVB/PAL	Unit	Note
Horizontal	Display Period	t _{HV}	960	960	tclk	
	Blank	t _{HB}	140	140	tclk	1
	Total	t _{HP}	1100	1100	tclk	
Vertical	Display Period	t _{VV}	1080	1080	Lines	
	Blank	t _{VB}	45	270	Lines	1
	Total	t _{VP}	1125	1350	Lines	

ITEM		Symbol	NTSC/ATSC	DVB/PAL	Unit	Note
Frequency	DCLK	f _{CLK}	74.25	74.25	MHz	148.5/2
	Horizontal	f _H	67.5	67.5	KHz	2
	Vertical	f _V	60	50	Hz	2

Note: 1. The input of HSYNC & VSYNC signal does not have an effect on normal operation (DE Only Mode).
 If you use spread spectrum of EMI, add some additional clock to minimum value for clock margin.

2. The performance of the electro-optical characteristics may be influenced by variance of the vertical refresh rate and the horizontal frequency

※ Timing should be set based on clock frequency.

Sunlight Readable LCDs With Optical Bonding + Touch Integration

Specification

3-4. LVDS Signal Specification

3-4-1. LVDS Input Signal Timing Diagram

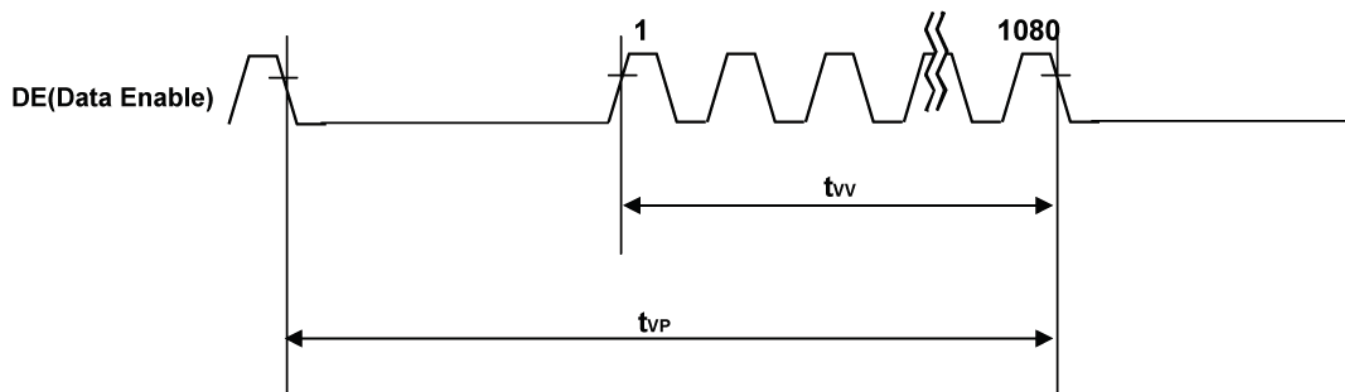
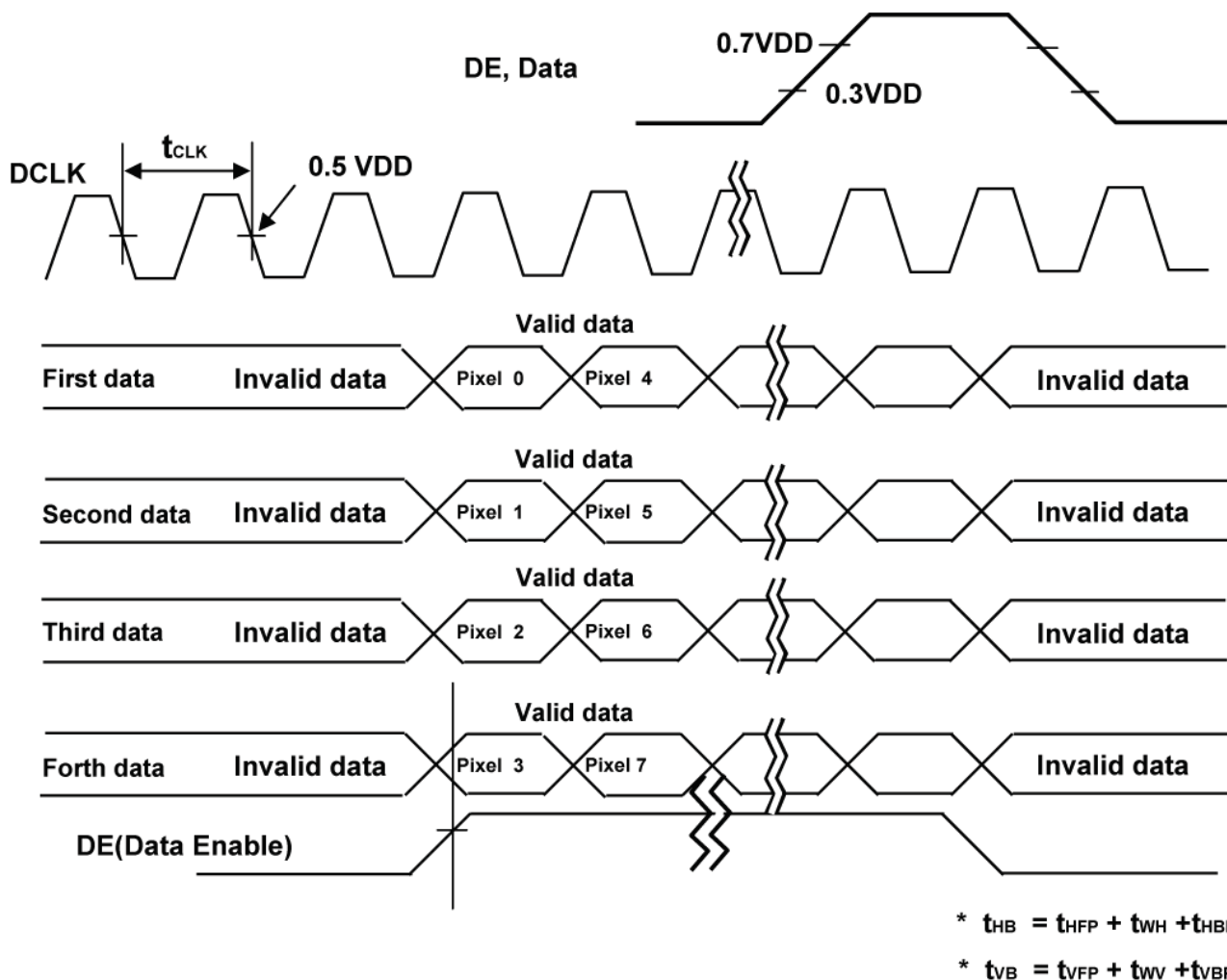

Sunlight Readable LCDs With Optical Bonding + Touch Integration



DP720FHDI

Specification

3-4-2. LVDS Input Signal Characteristics

1) DC Specification

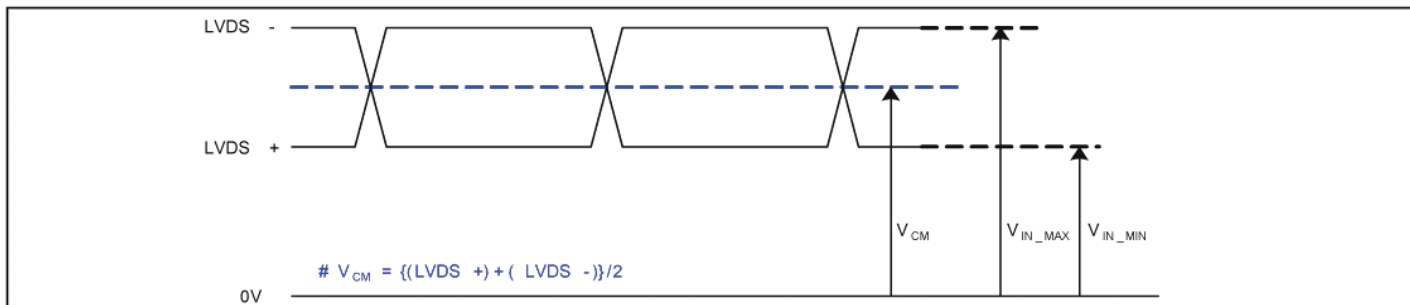

Description	Symbol	Min	Max	Unit	Note
LVDS Common mode Voltage	V_{CM}	1.0	1.5	V	-
LVDS Input Voltage Range	V_{IN}	0.7	1.8	V	-
Change in common mode Voltage	ΔV_{CM}		250	mV	-

2) AC Specification

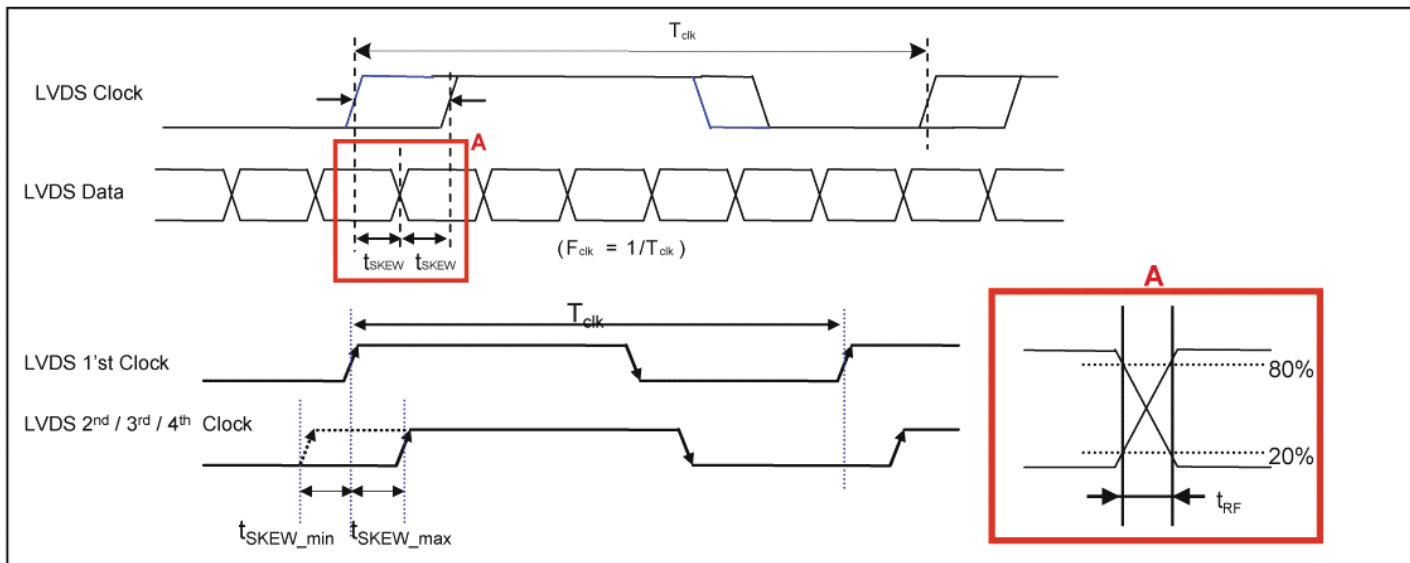

Description	Symbol	Min	Max	Unit	Note	
LVDS Differential Voltage	High Threshold	V_{TH}	100	300	mV	3
	Low Threshold	V_{TL}	-300	-100	mV	
LVDS Clock to Data Skew Margin	t_{SKEW}		$ (0.25 * T_{clk})/7 $	ps	-	
LVDS Clock/DATA Rising/Falling time	t_{RF}	260	$(0.3 * T_{clk})/7$	ps	2	
Effective time of LVDS	t_{eff}	± 360		ps	-	
LVDS Clock to Clock Skew Margin (Even to Odd)	t_{SKEW_EO}		$1/7 * T_{clk}$	T_{clk}	-	

- Note
- All Input levels of LVDS signals are based on the EIA 644 Standard.
 - If t_{RF} isn't enough, t_{eff} should be meet the range.
 - LVDS Differential Voltage is defined within t_{eff}

Sunlight Readable LCDs With Optical Bonding + Touch Integration

Specification

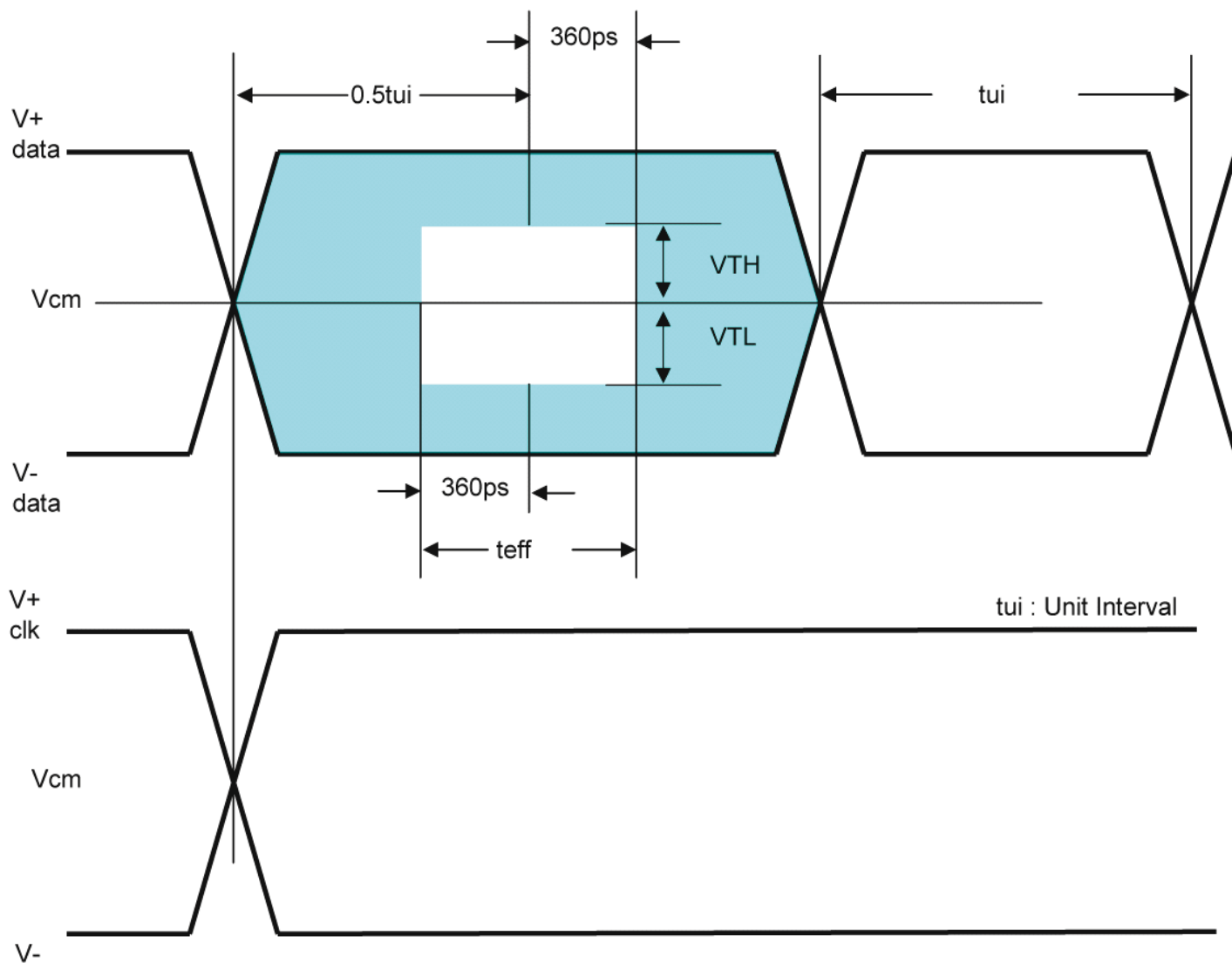

Sunlight Readable LCDs With Optical Bonding + Touch Integration

Specification

3-5. Color Data Reference

The brightness of each primary color(red,green,blue) is based on the 8bit gray scale data input for the color. The higher binary input, the brighter the color. Table 7 provides a reference for color versus data input.

Table 7. COLOR DATA REFERENCE

Color		Input Color Data																							
		RED								GREEN								BLUE							
		MSB							LSB	MSB							LSB	MSB							LSB
		R7	R6	R5	R4	R3	R2	R1	R0	G7	G6	G5	G4	G3	G2	G1	G0	B7	B6	B5	B4	B3	B2	B1	B0
Basic Color	Black	0	0	0	0	0	0	0	0	0	0	0	0	0	0	0	0	0	0	0	0	0	0	0	0
	Red (255)	1	1	1	1	1	1	1	1	0	0	0	0	0	0	0	0	0	0	0	0	0	0	0	0
	Green (255)	0	0	0	0	0	0	0	0	1	1	1	1	1	1	1	1	0	0	0	0	0	0	0	0
	Blue (255)	0	0	0	0	0	0	0	0	0	0	0	0	0	0	0	0	1	1	1	1	1	1	1	1
	Cyan	0	0	0	0	0	0	0	0	1	1	1	1	1	1	1	1	1	1	1	1	1	1	1	1
	Magenta	1	1	1	1	1	1	1	1	0	0	0	0	0	0	0	0	1	1	1	1	1	1	1	1
	Yellow	1	1	1	1	1	1	1	1	1	1	1	1	1	1	1	1	0	0	0	0	0	0	0	0
	White	1	1	1	1	1	1	1	1	1	1	1	1	1	1	1	1	1	1	1	1	1	1	1	1
RED	RED (000) Dark	0	0	0	0	0	0	0	0	0	0	0	0	0	0	0	0	0	0	0	0	0	0	0	0
	RED (001)	0	0	0	0	0	0	0	1	0	0	0	0	0	0	0	0	0	0	0	0	0	0	0	0
							
	RED (254)	1	1	1	1	1	1	1	0	0	0	0	0	0	0	0	0	0	0	0	0	0	0	0	0
	RED (255)	1	1	1	1	1	1	1	1	0	0	0	0	0	0	0	0	0	0	0	0	0	0	0	0
GREEN	GREEN (000) Dark	0	0	0	0	0	0	0	0	0	0	0	0	0	0	0	0	0	0	0	0	0	0	0	0
	GREEN (001)	0	0	0	0	0	0	0	0	0	0	0	0	0	0	0	1	0	0	0	0	0	0	0	0
							
	GREEN (254)	0	0	0	0	0	0	0	0	1	1	1	1	1	1	1	0	0	0	0	0	0	0	0	0
	GREEN (255)	0	0	0	0	0	0	0	0	1	1	1	1	1	1	1	1	0	0	0	0	0	0	0	0
BLUE	BLUE (000) Dark	0	0	0	0	0	0	0	0	0	0	0	0	0	0	0	0	0	0	0	0	0	0	0	0
	BLUE (001)	0	0	0	0	0	0	0	0	0	0	0	0	0	0	0	0	0	0	0	0	0	0	0	1
							
	BLUE (254)	0	0	0	0	0	0	0	0	0	0	0	0	0	0	0	0	1	1	1	1	1	1	1	0
	BLUE (255)	0	0	0	0	0	0	0	0	0	0	0	0	0	0	0	0	1	1	1	1	1	1	1	1

Sunlight Readable LCDs With Optical Bonding + Touch Integration

Specification

3-6. Power Sequence

3-6-1. LCD Driving circuit

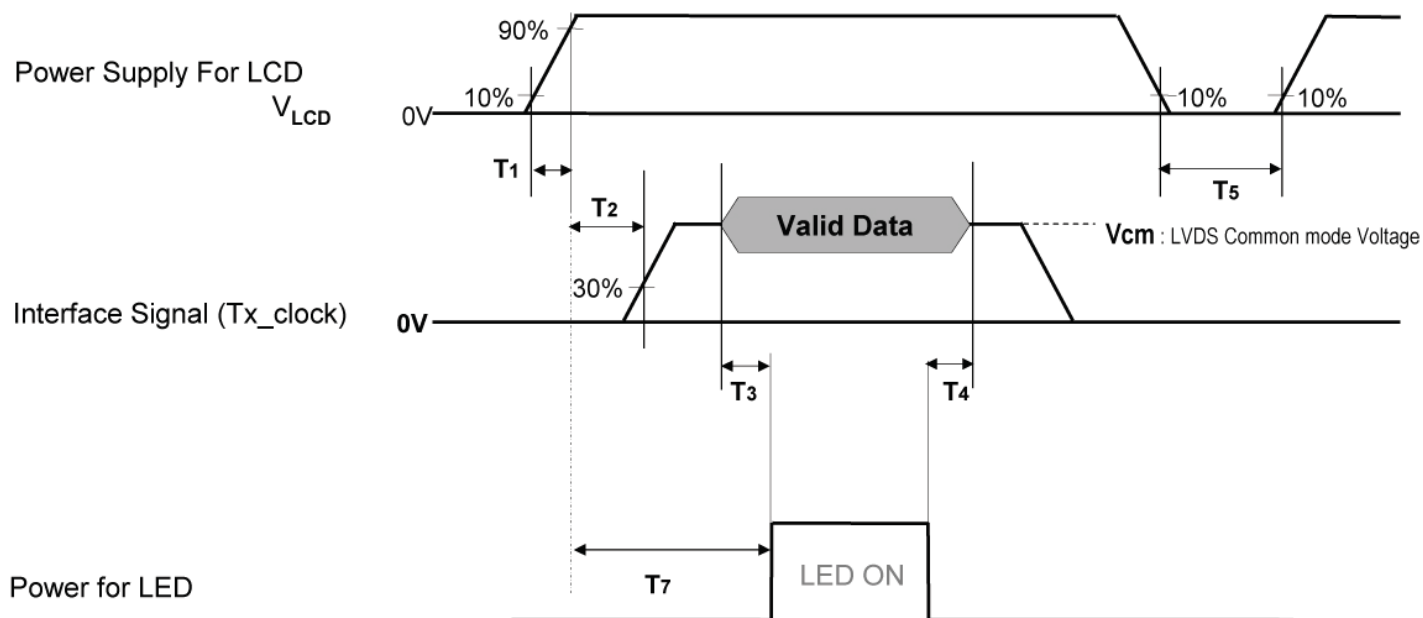
**Table 8. POWER SEQUENCE**

Parameter	Value			Unit	Notes
	Min	Typ	Max		
T1	0.5	-	20	ms	
T2	0	-	-	ms	4
T3	3	-	-	S	3
T4	200	-	-	ms	3
T5	1.0	-	-	s	4
T7	4	-	-	s	

- Note :
1. Please avoid floating state of interface signal at invalid period.
 2. When the power supply for LCD (V_{LCD}) is off, be sure to pull down the valid and invalid data to 0V.
 3. The $T3 / T4$ is recommended value, the case when failed to meet a minimum specification, abnormal display would be shown. There is no reliability problem.
 4. $T5$ should be measured after the Module has been fully discharged between power off and on period.

Specification

3-6-2. Sequence for LED Driver

Power Supply For LED Driver

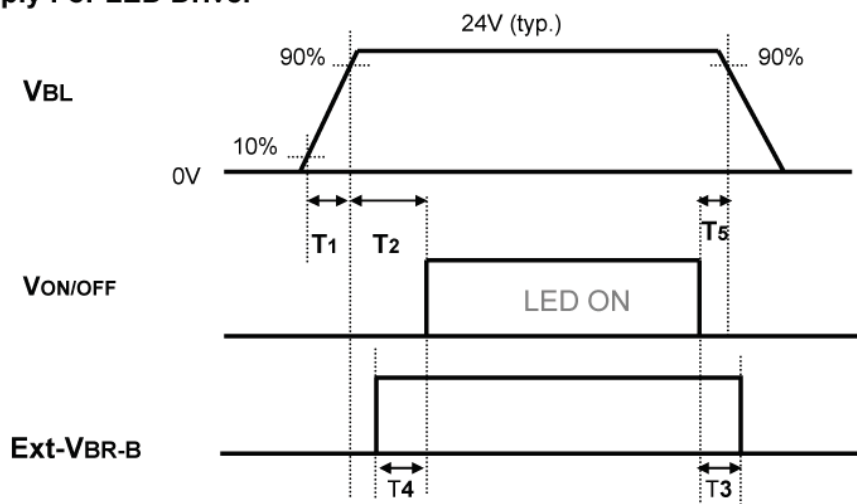

3-6-3. Dip condition for LED Driver

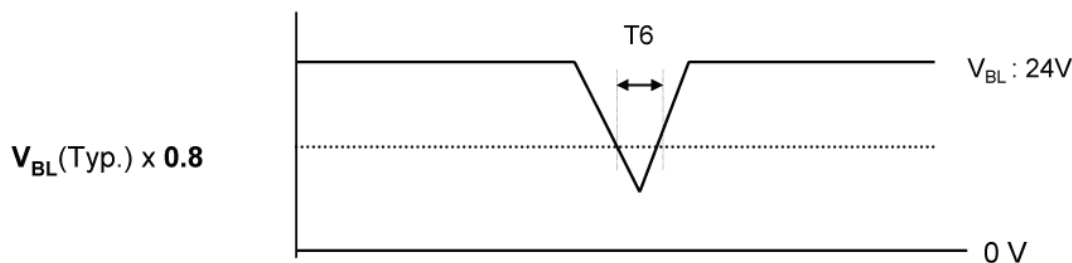
**Table 9. Power Sequence for LED Driver**

Parameter	Values			Units	Remarks
	Min	Typ	Max		
T1	20	-	-	ms	1
T2	500	-	-	ms	
T3	10	-	-	ms	
T4	0	-	-	ms	
T5	0	-	-	ms	
T6	-	-	10	ms	$V_{BL}(Typ) \times 0.8$

Notes : 1. T1 describes rising time of 0V to 24V and this parameter does not applied at restarting time.
 Even though T1 is over the specified value, there is no problem if I2T spec of fuse is satisfied.

Sunlight Readable LCDs With Optical Bonding + Touch Integration

Specification

4. Optical Specification

Optical characteristics are determined after the unit has been 'ON' and stable in a dark environment at $25\pm 2^{\circ}\text{C}$. The values are specified at an approximate distance 50cm from the LCD surface at a viewing angle of Φ and θ equal to 0° .

It is presented additional information concerning the measurement equipment and method in FIG. 1.

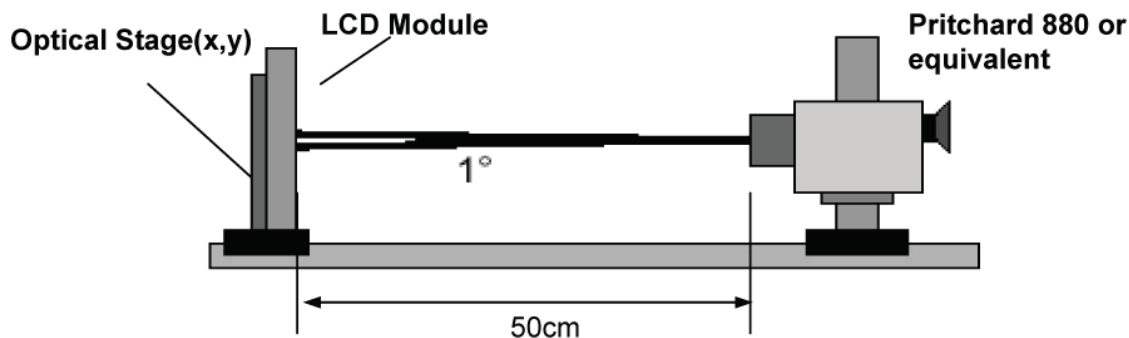

FIG. 1 Optical Characteristic Measurement Equipment and Method

$T_a = 25\pm 2^{\circ}\text{C}$, $V_{\text{LCD}} = 12.0\text{V}$, $f_v = 240\text{Hz}$, $D_{\text{clk}} = 74.25\text{MHz}$,
EXTV_{BR-B} = 100%

Table 10. OPTICAL CHARACTERISTICS

Parameter	Symbol	Value			Unit	Note	
		Min	Typ	Max			
Contrast Ratio	CR	900(TBD)	1100(TBD)	-		1	
Surface Luminance, white	L_{WH}	1900	2000	-	cd/m ²	2	
Luminance Variation	δ_{WHITE} 5P	-	-	1.3		3	
Response Time	Gray-to-Gray	G to G	-	12(TBD)	17(TBD)	ms	4
Color Coordinates [CIE1931]	RED	Rx	Typ -0.03	0.646 (TBD)	Typ +0.03		
		Ry		0.330 (TBD)			
	GREEN	Gx		0.303 (TBD)			
		Gy		0.600 (TBD)			
	BLUE	Bx		0.152 (TBD)			
		By		0.059 (TBD)			
	WHITE	Wx		0.279			
		Wy		0.292			
Color Temperature			10,000		K		
Color Gamut			72		%		
Viewing Angle (CR>10)							
	x axis, right($\phi=0^{\circ}$)	θ_r	89	-	-	degree	5
	x axis, left ($\phi=180^{\circ}$)	θ_l	89	-	-		
	y axis, up ($\phi=90^{\circ}$)	θ_u	89	-	-		
	y axis, down ($\phi=270^{\circ}$)	θ_d	89	-	-		
Gray Scale			-	-	-		6

Sunlight Readable LCDs With Optical Bonding + Touch Integration

Specification

Note : 1. Contrast Ratio(CR) is defined mathematically as :

$$CR = \frac{\text{Surface Luminance at all white pixels}}{\text{Surface Luminance at all black pixels}}$$

It is measured at center 1-point.

- Surface luminance is determined after the unit has been 'ON' and 1Hour after lighting the backlight in a dark environment at $25 \pm 2^\circ\text{C}$. Surface luminance is the luminance value at center 1-point across the LCD surface 50cm from the surface with all pixels displaying white. For more information see the FIG. 10.
- The variation in surface luminance, δ WHITE is defined as :
 δ WHITE(5P) = Maximum($L_{on1}, L_{on2}, L_{on3}, L_{on4}, L_{on5}$) / Minimum($L_{on1}, L_{on2}, L_{on3}, L_{on4}, L_{on5}$)
 Where L_{on1} to L_{on5} are the luminance with all pixels displaying white at 5 locations .
 For more information, see the FIG. 10.
- Response time is the time required for the display to transit from G(255) to G(0) (Rise Time, Tr_R) and from G(0) to G(255) (Decay Time, Tr_D).
- Viewing angle is the angle at which the contrast ratio is greater than 10. The angles are determined for the horizontal or x axis and the vertical or y axis with respect to the z axis which is normal to the LCD module surface. For more information, see the FIG. 12.
- Gray scale specification
 Gamma Value is approximately 2.2. For more information, see the Table 10.

Table 10. GRAY SCALE SPECIFICATION

Gray Level	Luminance [%] (Typ)
L0	0.08 (TBD)
L15	0.28(TBD)
L31	1.05(TBD)
L47	2.50(TBD)
L63	4.69(TBD)
L79	7.67(TBD)
L95	11.47(TBD)
L111	16.11(TBD)
L127	21.64(TBD)
L143	28.07(TBD)
L159	35.43(TBD)
L175	43.73(TBD)
L191	52.99(TBD)
L207	63.23(TBD)
L223	74.47(TBD)
L239	86.72(TBD)
L255	100

Sunlight Readable LCDs With Optical Bonding + Touch Integration

Specification

Measuring point for surface luminance & luminance variation

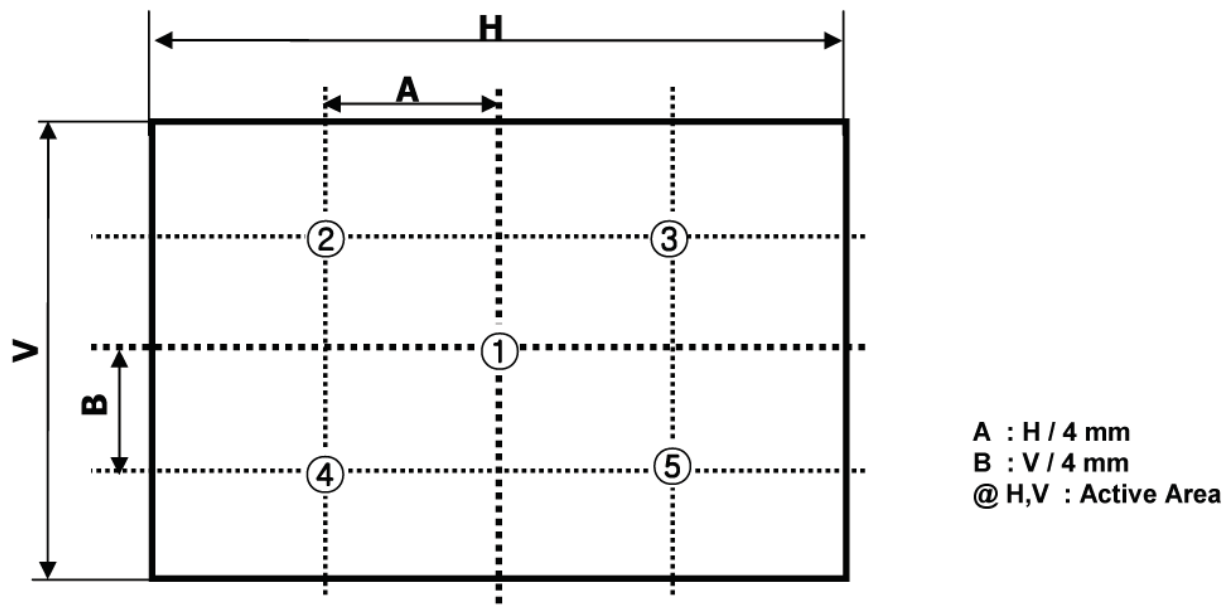

FIG. 10 5 Points for Luminance Measure

Response time is defined as the following figure and shall be measured by switching the input signal for Black and White

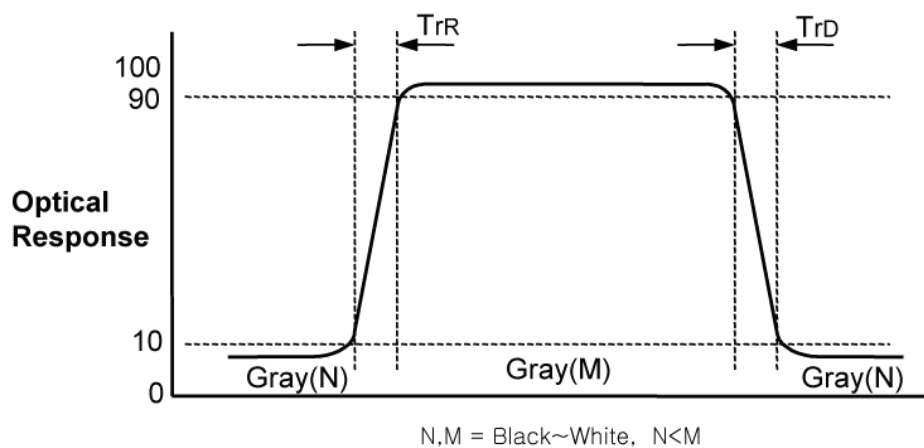

FIG. 11 Response Time

Sunlight Readable LCDs With Optical Bonding + Touch Integration

Specification

Dimension of viewing angle range

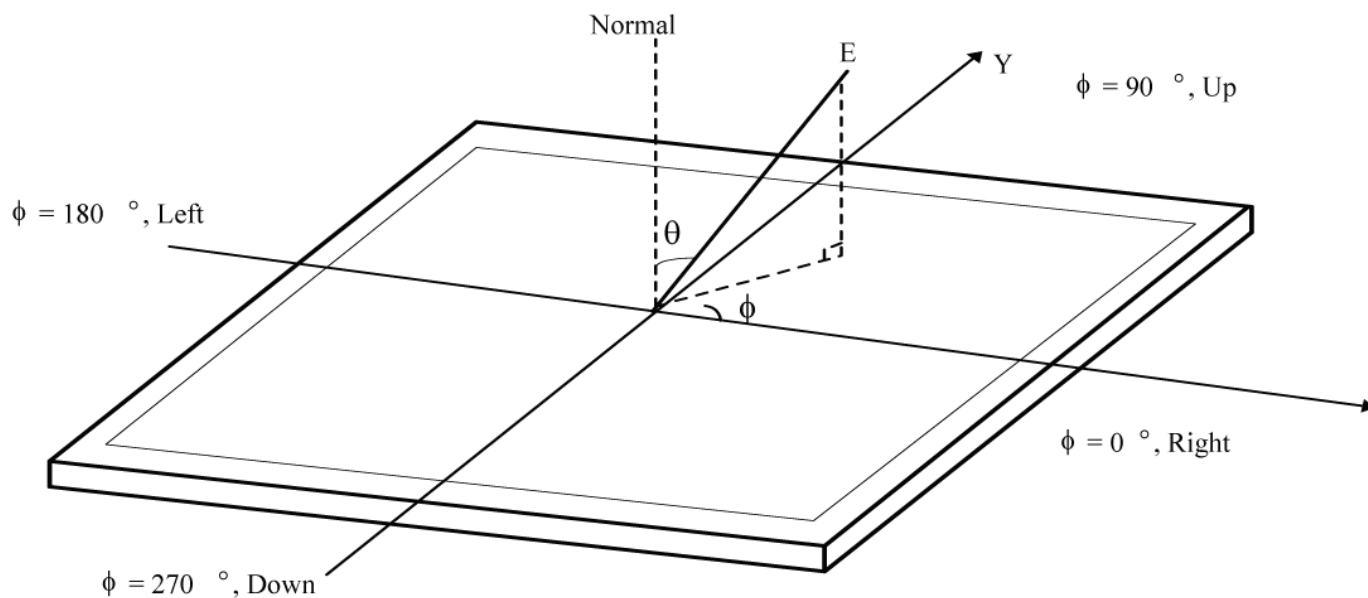

FIG.12 Viewing Angle

Sunlight Readable LCDs With Optical Bonding + Touch Integration

Specification

5. Mechanical Characteristics

Table 11 provides general mechanical characteristics.

Table 11. MECHANICAL CHARACTERISTICS

Item	Value	
Outline Dimension	Horizontal	1666.0 mm
	Vertical	968.0 mm
	Depth	60.0 mm
Bezel Area	Horizontal	1606.0mm
	Vertical	908.0mm
Active Display Area	Horizontal	1595.52 mm
	Vertical	897.48 mm
Weight	37kg	

Note : Please refer to a mechanical drawing in terms of tolerance at the next page.

Sunlight Readable LCDs With Optical Bonding + Touch Integration

Specification

[FRONT VIEW]

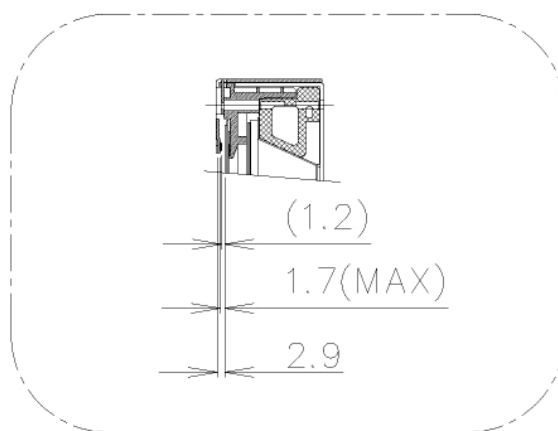
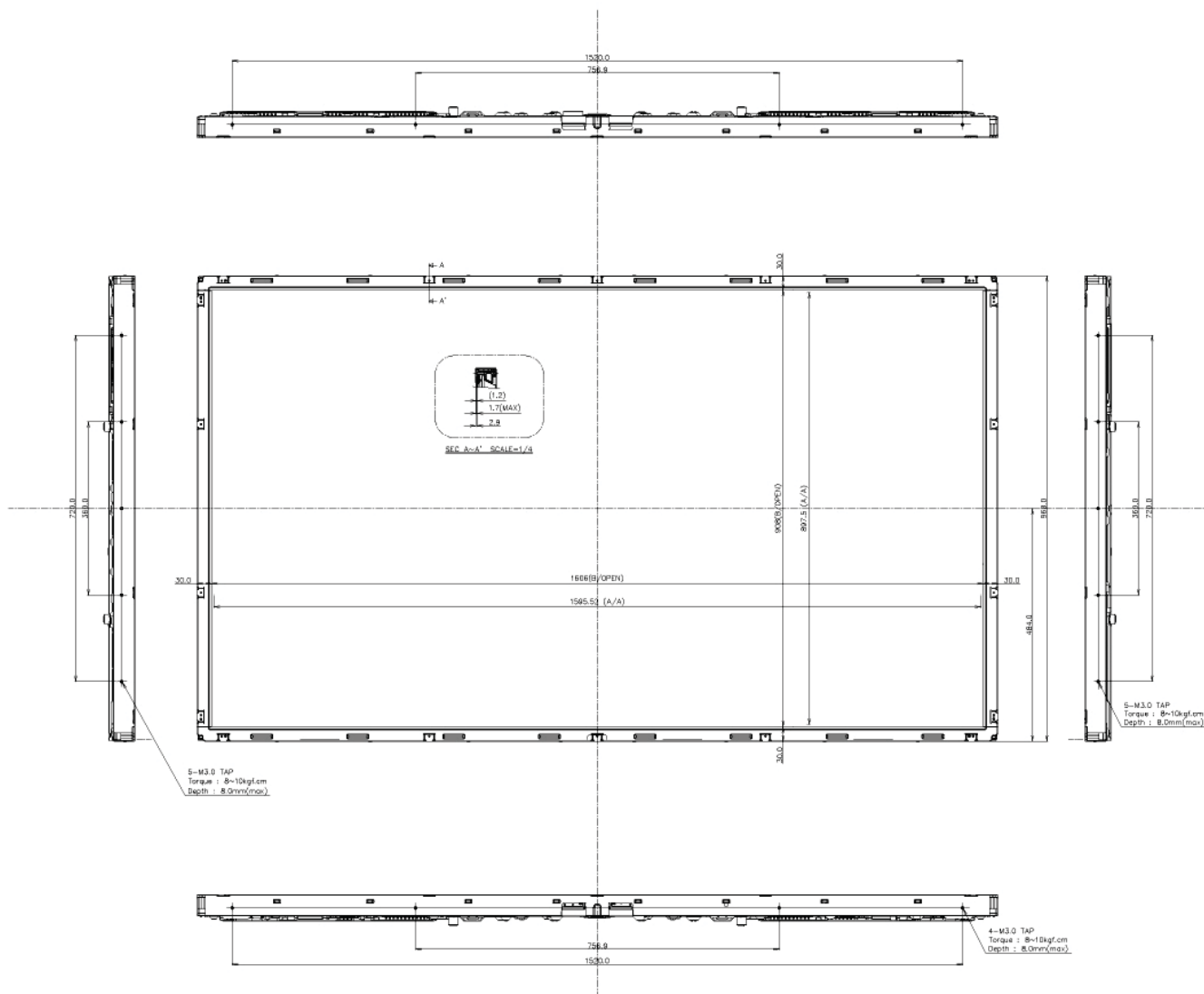

SEC. A~A' SCALE=1/4

Sunlight Readable LCDs With Optical Bonding + Touch Integration



DP720FHDI

Specification

[REAR VIEW]

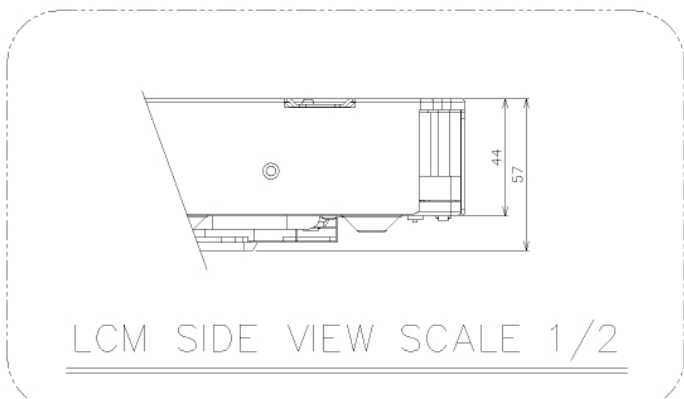
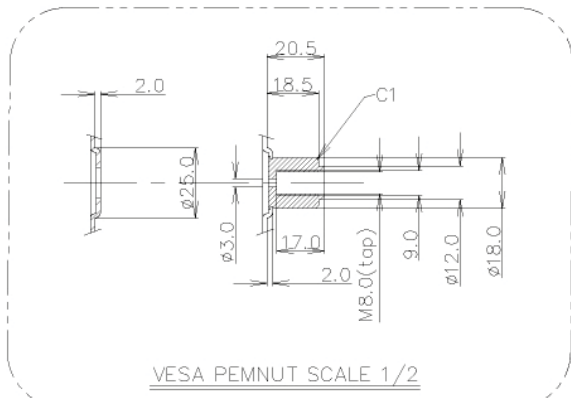
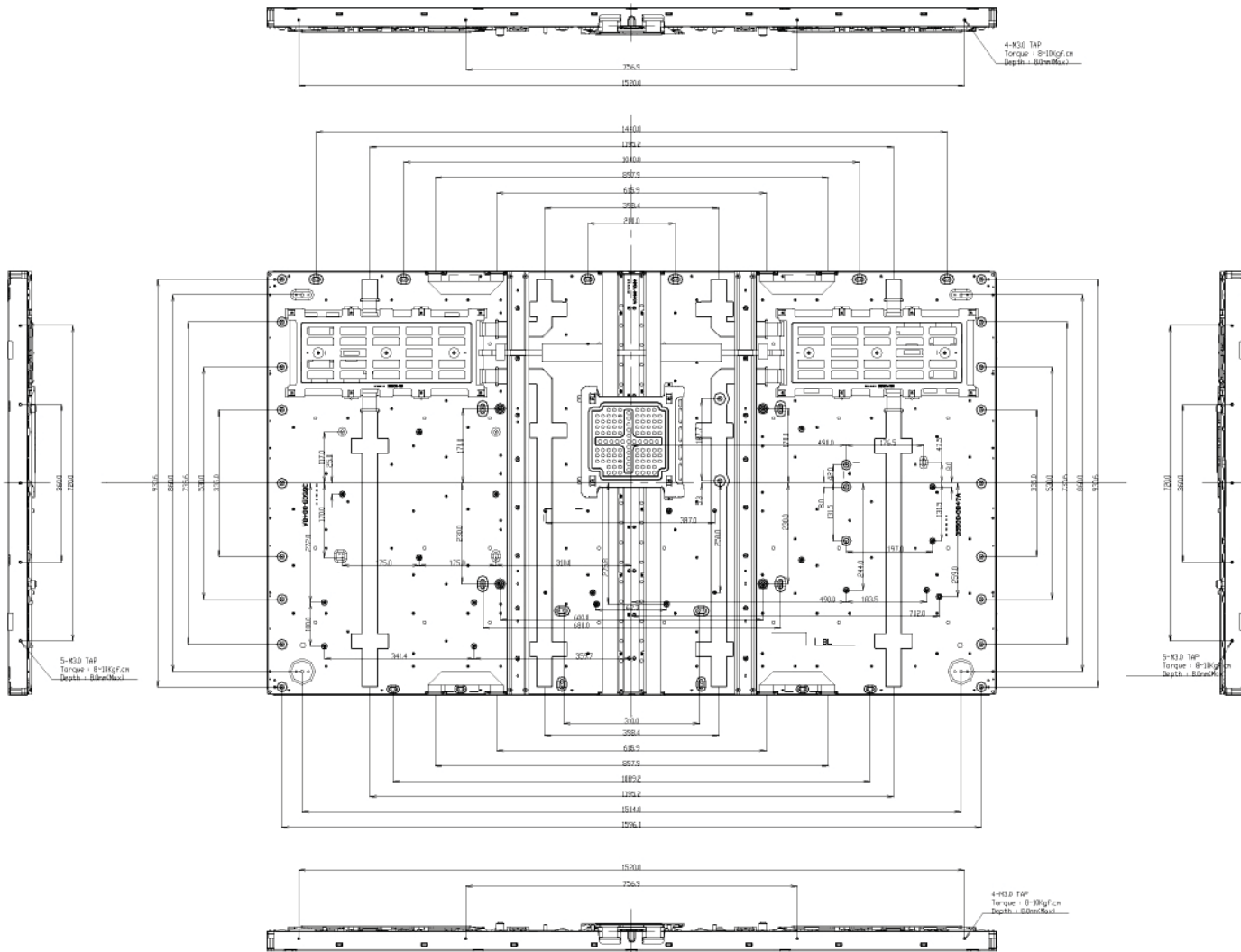

Sunlight Readable LCDs With Optical Bonding + Touch Integration

Specification

6. Reliability

Table 12. ENVIRONMENT TEST CONDITION

No.	Test Item	Condition
1	High temperature storage test	Ta= 60°C 240h
2	Low temperature storage test	Ta= -20°C 240h
3	High temperature operation test	Ta= 50°C 50%RH 240h
4	Low temperature operation test	Ta= 0°C 240h
5	Vibration test (non-operating)	Wave form : random Vibration level : 1.0Grms Bandwidth : 10-300Hz Duration : X,Y,Z, 30 min Each direction per 10 min
6	Humidity condition Operation	Ta= 40 °C ,90%RH
7	Altitude operating storage / shipment	0 - 15,000 ft 0 - 40,000 ft

Note : Before and after Reliability test, LCM should be operated with normal function.

Sunlight Readable LCDs With Optical Bonding + Touch Integration

Specification

7. International Standards

7-1. Safety

- a) UL 60950-1, Underwriters Laboratories Inc.
Information Technology Equipment - Safety - Part 1 : General Requirements.
- b) CAN/CSA C22.2 No.60950-1-07, Canadian Standards Association.
Information Technology Equipment - Safety - Part 1 : General Requirements.
- c) EN 60950-1, European Committee for Electrotechnical Standardization (CENELEC).
Information Technology Equipment - Safety - Part 1 : General Requirements.
- d) IEC 60950-1, The International Electrotechnical Commission (IEC).
Information Technology Equipment - Safety - Part 1 : General Requirements.
(Including report of IEC60825-1:2001 clause 8 and clause 9)

Notes

1. Laser (LED Backlight) Information

Class 1M LED Product IEC60825-1 : 2001 Embedded LED Power (Class1M)

2. Caution

- : LED inside.
- Class 1M laser (LEDs) radiation when open.
- Do not open while operating.

7-2. EMC

- a) ANSI C63.4 "American National Standard for Methods of Measurement of Radio-Noise Emissions from Low-Voltage Electrical and Electronic Equipment in the Range of 9 kHz to 40 GHz." American National Standards Institute (ANSI), 2003.
- b) CISPR 22 "Information technology equipment – Radio disturbance characteristics – Limit and methods of measurement." International Special Committee on Radio Interference (CISPR), 2005.
- c) CISPR 13 "Sound and television broadcast receivers and associated equipment – Radio disturbance characteristics – Limits and method of measurement." International Special Committee on Radio Interference (CISPR), 2006.

7-3. Environment

- a) RoHS, Directive 2002/95/EC of the European Parliament and of the council of 27 January 2003

Sunlight Readable LCDs With Optical Bonding + Touch Integration

Specification

8. Packing

8-1. Information of LCM Label

a) Lot Mark

A	B	C	D	E	F	G	H	I	J	K	L	M
---	---	---	---	---	---	---	---	---	---	---	---	---

A,B,C : SIZE(INCH)

E : MONTH

D : YEAR

F ~ M : SERIAL NO.

Note

1. YEAR

Year	2010	2011	2012	2013	2014	2015	2016	2017	2018	2019
Mark	0	1	2	3	4	5	6	7	8	9

2. MONTH

Month	Jan	Feb	Mar	Apr	May	Jun	Jul	Aug	Sep	Oct	Nov	Dec
Mark	1	2	3	4	5	6	7	8	9	A	B	C

b) Location of Lot Mark

Serial NO. is printed on the label. The label is attached to the backside of the LCD module.
This is subject to change without prior notice.

8-2. Packing Form

a) Package quantity in one Pallet : 6ea

b) Pallet Size : 190mm0 X 1140mm X 1248mm

Sunlight Readable LCDs With Optical Bonding + Touch Integration

Specification

9. Precautions

Please pay attention to the followings when you use this TFT LCD module.

9-1. Mounting Precautions

- (1) You must mount a module using specified mounting holes (Details refer to the drawings).
- (2) You should consider the mounting structure so that uneven force (ex. Twisted stress) is not applied to the module. And the case on which a module is mounted should have sufficient strength so that external force is not transmitted directly to the module.
- (3) Please attach the surface transparent protective plate to the surface in order to protect the polarizer. Transparent protective plate should have sufficient strength in order to resist external force.
- (4) You should adopt radiation structure to satisfy the temperature specification.
- (5) Acetic acid type and chlorine type materials for the cover case are not desirable because the former generates corrosive gas of attacking the polarizer at high temperature and the latter causes circuit break by electro-chemical reaction.
- (6) Do not touch, push or rub the exposed polarizers with glass, tweezers or anything harder than HB pencil lead. And please do not rub with dust clothes with chemical treatment. Do not touch the surface of polarizer for bare hand or greasy cloth. (Some cosmetics are detrimental to the polarizer.)
- (7) When the surface becomes dusty, please wipe gently with absorbent cotton or other soft materials like chamois soaks with petroleum benzine. Normal-hexane is recommended for cleaning the adhesives used to attach front / rear polarizers. Do not use acetone, toluene and alcohol because they cause chemical damage to the polarizer.
- (8) Wipe off saliva or water drops as soon as possible. Their long time contact with polarizer causes deformations and color fading.
- (9) Do not open the case because inside circuits do not have sufficient strength.

9-2. Operating Precautions

- (1) The spike noise causes the mis-operation of circuits. It should be lower than following voltage :
 $V = \pm 200\text{mV}$ (Over and under shoot voltage)
- (2) Response time depends on the temperature. (In lower temperature, it becomes longer.)
- (3) Brightness depends on the temperature. (In lower temperature, it becomes lower.)
And in lower temperature, response time (required time that brightness is stable after turned on) becomes longer
- (4) Be careful for condensation at sudden temperature change. Condensation makes damage to polarizer or electrical contacted parts. And after fading condensation, smear or spot will occur.
- (5) When fixed patterns are displayed for a long time, remnant image is likely to occur.
- (6) Module has high frequency circuits. Sufficient suppression to the electromagnetic interference shall be done by system manufacturers. Grounding and shielding methods may be important to minimize the interference.
- (7) Please do not give any mechanical and/or acoustical impact to LCM. Otherwise, LCM can't be operated its full characteristics perfectly.
- (8) A screw which is fastened up the steels should be a machine screw.
(if not, it can cause conductive particles and deal LCM a fatal blow)
- (9) Please do not set LCD on its edge.
- (10) The conductive material and signal cables are kept away from LED driver inductor to prevent abnormal display, sound noise and temperature rising.

Sunlight Readable LCDs With Optical Bonding + Touch Integration

Specification

9-3. Electrostatic Discharge Control

Since a module is composed of electronic circuits, it is not strong to electrostatic discharge. Make certain that treatment persons are connected to ground through wrist band etc. And don't touch interface pin directly.

9-4. Precautions for Strong Light Exposure

Strong light exposure causes degradation of polarizer and color filter.

9-5. Storage

When storing modules as spares for a long time, the following precautions are necessary.

- (1) Store them in a dark place. Do not expose the module to sunlight or fluorescent light. Keep the temperature between 5°C and 35°C at normal humidity.
- (2) The polarizer surface should not come in contact with any other object.
It is recommended that they be stored in the container in which they were shipped.

9-6. Handling Precautions for Protection Film

- (1) The protection film is attached to the bezel with a small masking tape.
When the protection film is peeled off, static electricity is generated between the film and polarizer.
This should be peeled off slowly and carefully by people who are electrically grounded and with well ion-blown equipment or in such a condition, etc.
- (2) When the module with protection film attached is stored for a long time, sometimes there remains a very small amount of glue still on the bezel after the protection film is peeled off.
- (3) You can remove the glue easily. When the glue remains on the bezel surface or its vestige is recognized, please wipe them off with absorbent cotton waste or other soft material like chamois soaked with normal-hexane.

9-7. Appropriate Condition for Public Display

- Generally large-sized LCD modules are designed for consumer applications (TV).
Accordingly, a long-term display like in Public Display (PD) application, can cause uneven display including image sticking. To optimize module's lifetime and function, several operating usages are required.

1. Normal operating condition
 - Temperature: 0 ~ 40°C
 - Operating Ambient Humidity : 10 ~ 90 %
 - Display pattern: dynamic pattern (Real display)
 - Note) Long-term static display can cause image sticking.
2. Operating usages under abnormal condition
 - a. Ambient condition
 - Well-ventilated place is recommended to set up PD system.
 - b. Power and screen save
 - Periodical power-off or screen save is needed after long-term display.

Sunlight Readable LCDs With Optical Bonding + Touch Integration

Specification

3. Operating usages to protect against image sticking due to long-term static display
 - a. Suitable operating time: under 18 hours a day.
 - b. Static information display recommended to use with moving image.
 - Cycling display between 5 minutes' information(static) display and 10 seconds' moving image.
 - c. Background and character (image) color change
 - Use different colors for background and character, respectively.
 - Change colors themselves periodically.
 - d. Avoid combination of background and character with large different luminance.
 - 1) Abnormal condition just means conditions except normal condition.
 - 2) Black image or moving image is strongly recommended as a screen save.
4. Lifetime in this spec. is guaranteed only when PD is used according to operating usages.
5. Module should be turned counterclockwise or clockwise based on front view when used in portrait mode.

Sunlight Readable LCDs With Optical Bonding + Touch Integration

Specification

APPENDIX-I

■ DP720FHDI – Pallet Ass'y

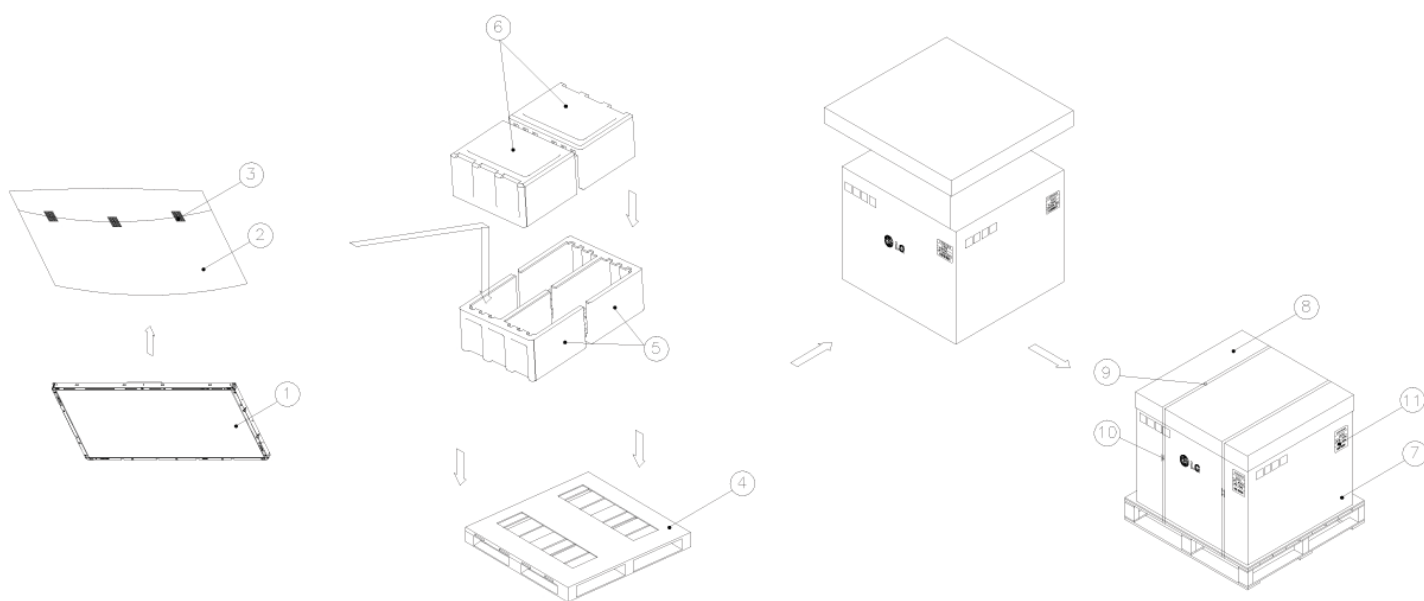

NO.	DESCRIPTION	MATERIAL
1	LCD Module	
2	BAG	72INCH
3	TAPE	MASKING 20MM X 50M
4	PALLET	Plywood (1900X1140X126.5)
5	PACKING	EPS
6	PACKING	EPS
7	ANGLE PACKING	PAPER
8	ANGLE COVER	PAPER
9	BAND,CLIP	STEEL
10	BAND	PP
11	LABEL	YUPO PAPER 80G 100X70

Sunlight Readable LCDs With Optical Bonding + Touch Integration



DP720FHDI

Specification

APPENDIX- II-1

■ DP720FHDI -LCM Label



www.panelook.com

Sunlight Readable LCDs With Optical Bonding + Touch Integration

Specification

APPENDIX- II-2

■ DP720FHDI-Pallet Label

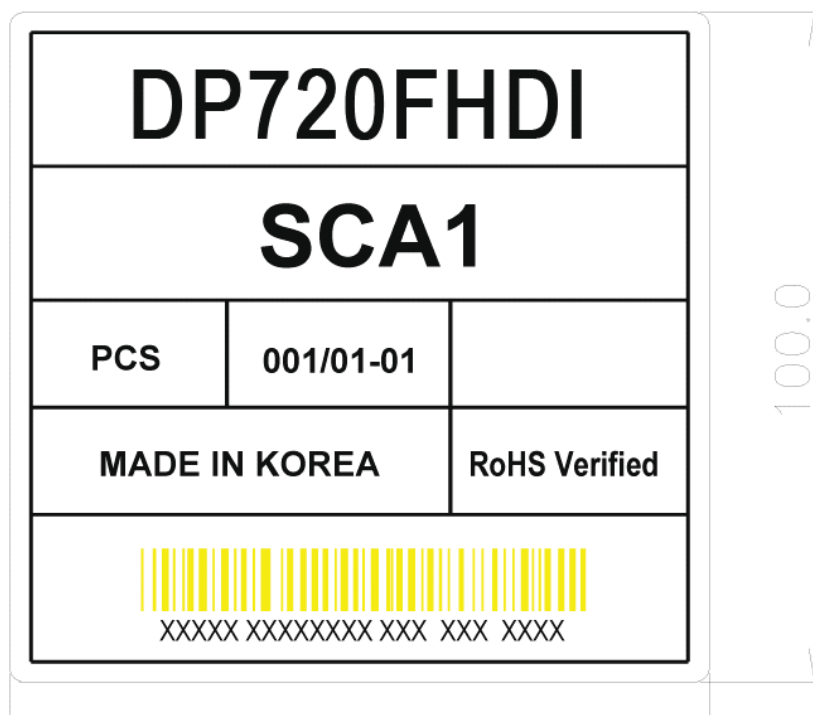

Sunlight Readable LCDs With Optical Bonding + Touch Integration

Specification

APPENDIX- III-1

■ Required signal assignment for Flat Link (Thine : THC63LVD103) Transmitter(Pin7=NC)

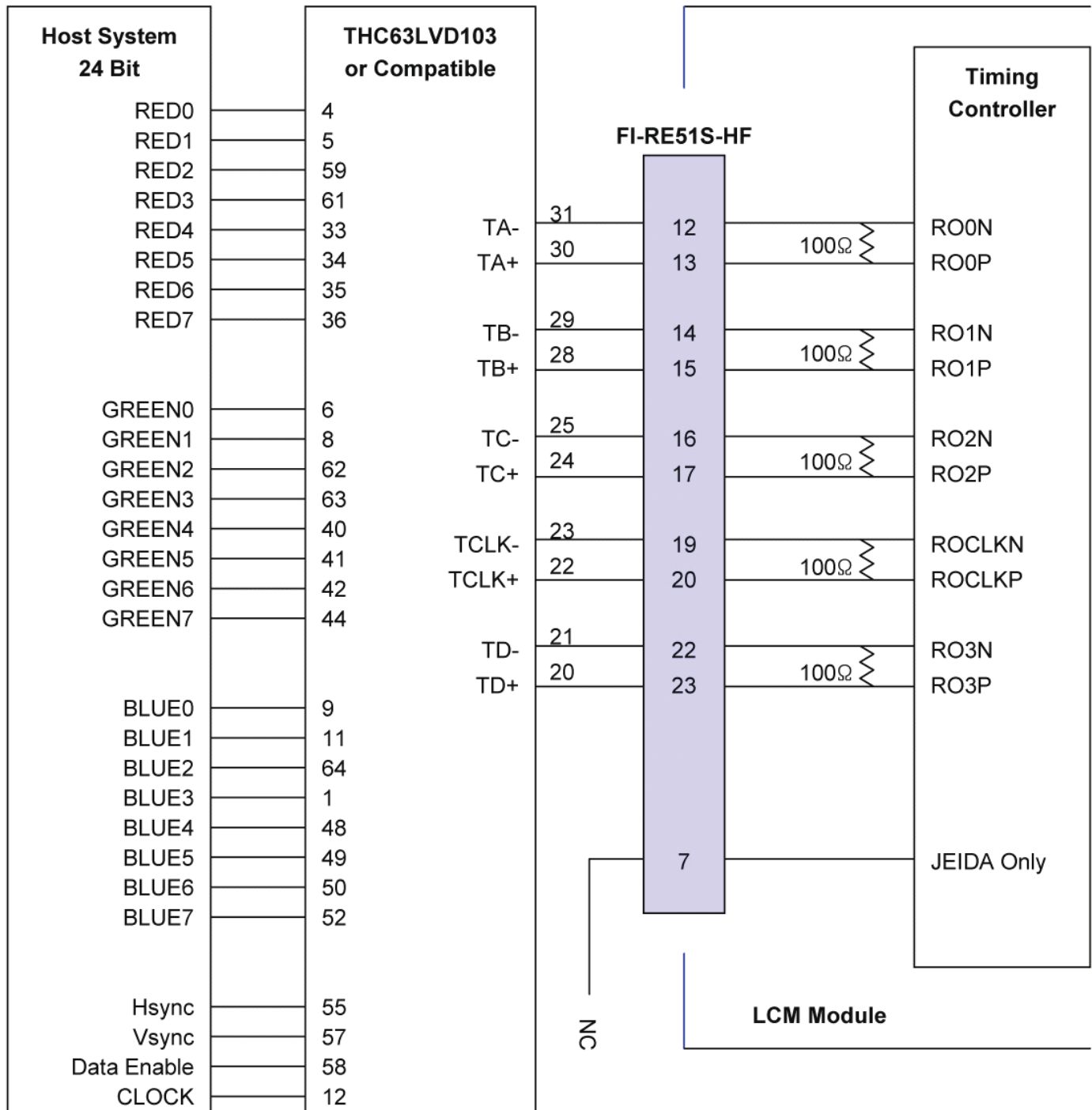

Note :1. The LCD module uses a 100 Ohm[Ω] resistor between positive and negative lines of each receiver input.

2. Refer to LVDS Transmitter Data Sheet for detail descriptions. (THC63LVD103 or Compatible)

3. '7' means MSB and '0' means LSB at R,G,B pixel data.

Sunlight Readable LCDs With Optical Bonding + Touch Integration

Specification

APPENDIX- III-2

■ LVDS Data-Mapping Information (8 Bit)

1) LVDS Select : "H" Data-Mapping (JEIDA format)

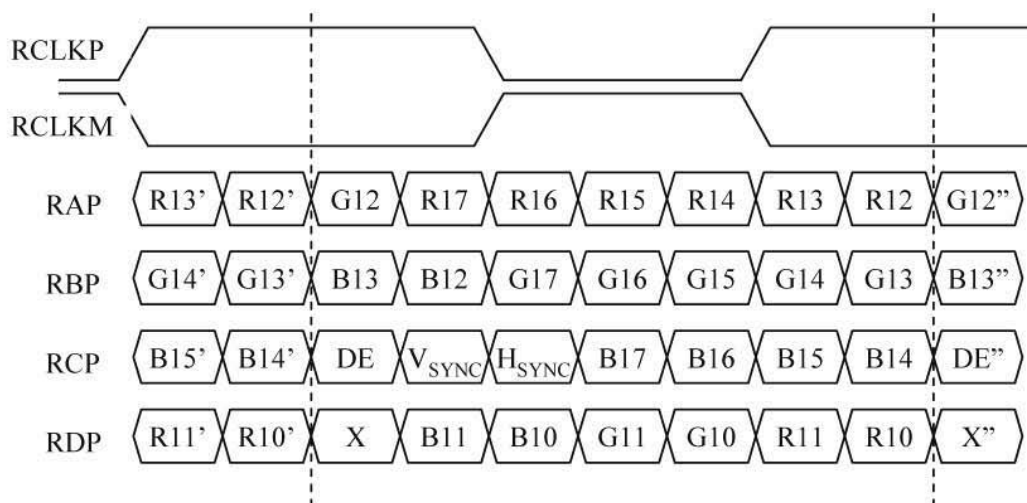

APPENDIX- III-3

■ Option Pin Circuit Block Diagram

1) Circuit Block Diagram of Local Dimming(L-Dim) Enable Selection pin

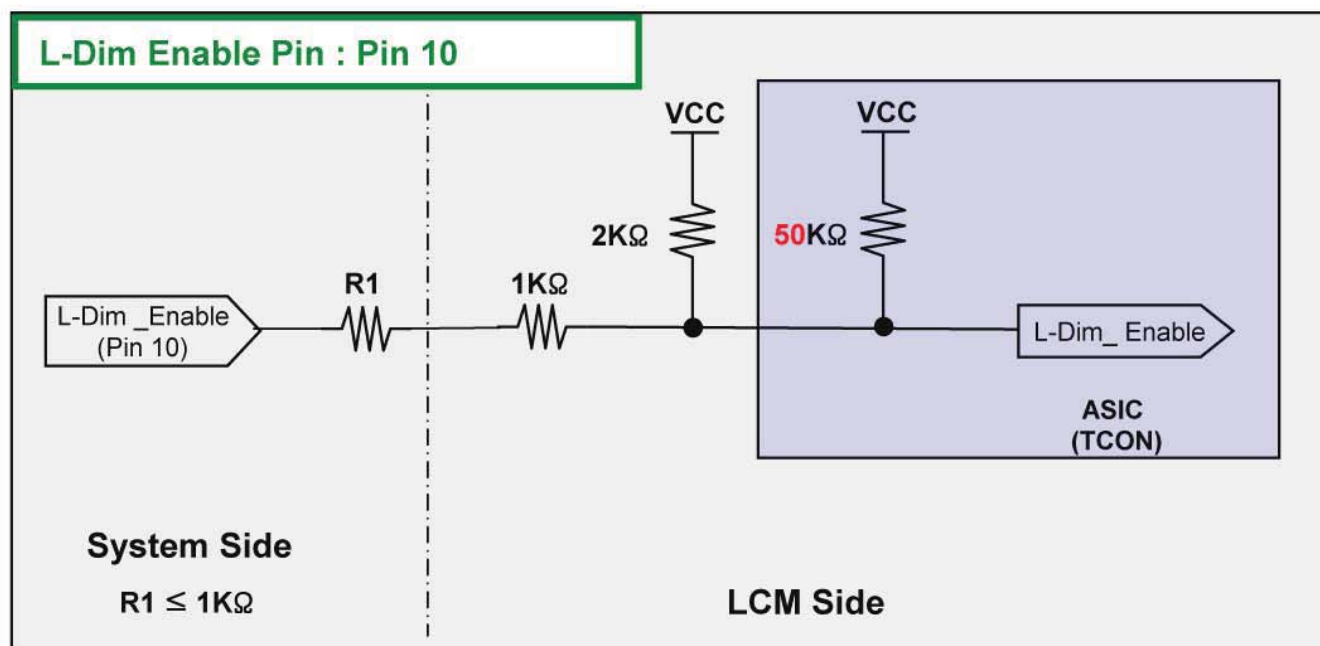

Sunlight Readable LCDs With Optical Bonding + Touch Integration