

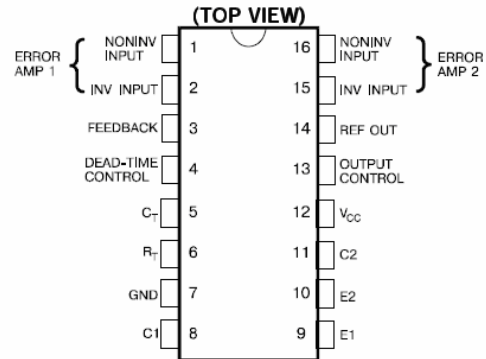

FEATURES

- Complete PWM Power Control Circuitry
- Uncommitted Outputs for 200 mA Sink or Source Current
- Output Control Selects Single-Ended or Push-Pull Operation
- Internal Circuitry Prohibits Double Pulse at Either Output
- Variable Dead-Time Provides Control over Total Range
- Internal Regulator Provides a Stable 5-V Reference Supply, 1%
- Circuit Architecture Allows Easy Synchronization



DESCRIPTION

The DP7500 incorporate on a single monolithic chip all the functions required in the construction of a pulse-width-modulation control circuit. Designed primarily for power supply control, these devices offer the systems engineer the flexibility to tailor the power supply control circuitry to his application.

The DP7500 contains an error amplifier, an on-chip adjustable oscillator, a dead-time control comparator, pulse-steering control flip-flop, a 5-volt, 1% precision regulator, and output-control circuits. The error amplifier exhibits a common-mode voltage range from -0.3 volts to $V_{CC} - 2$ volts. The dead-time control comparator has a fixed offset that provides approximately 5% dead time when externally altered. The on-chip oscillator may be bypassed by terminating R_T (pin 6) to the reference output and providing a sawtooth input to C_T (pin 5), or it may be used to drive the common circuits in synchronous multiple-rail power supplies. The uncommitted output transistors provide either common-emitter or emitter-follower output capability. Each device provides for push-pull or single-ended output operation, which may be selected through the output-control function. The architecture of these devices prohibits the possibility of either output being pulsed twice during push-pull operation.

Absolute maximum ratings over operating free-air temperature range (unless otherwise noted)

Rating	Value	Unit
Supply voltage, V_{CC}	42	V
Amplifier input voltage	$V_{CC} + 0.3$	
Collector output voltage	41	mA
Collector output current	250	
Operating free-air temperature range	0 to 70	°C
Storage temperature range	-65 to 150	
Lead temperature 1,6 mm from case for 10 seconds	260	

Recommended operating conditions

Parameter	Value		Unit
	MIN	MAX	
Supply voltage, V_{CC}	7	40	V
Amplifier input voltage, V_i	-0.3	$V_{CC} - 2$	
Collector output voltage, V_o		40	mA
Collector output current (each transistor)		200	
Current into feedback terminal		0.3	
Timing capacitor, C_T	0.0047	10	μF
Timing resistor, R_T	1.8	500	kΩ
Oscillator frequency	1	200	kHz
Operating free-air temperature, T_A	0	70	°C

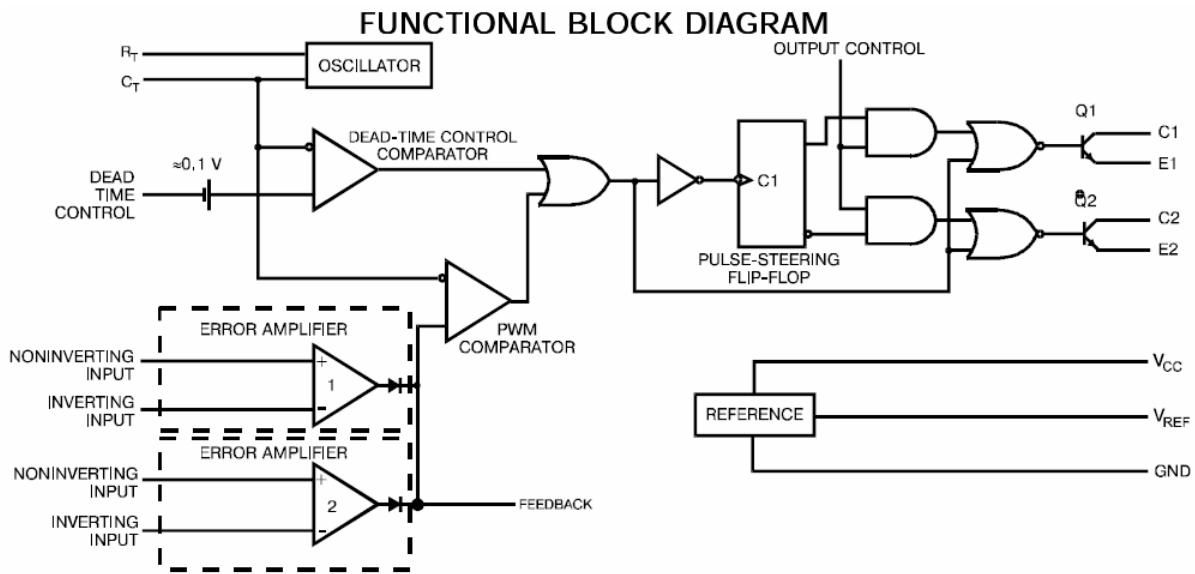

Parameter measurement information

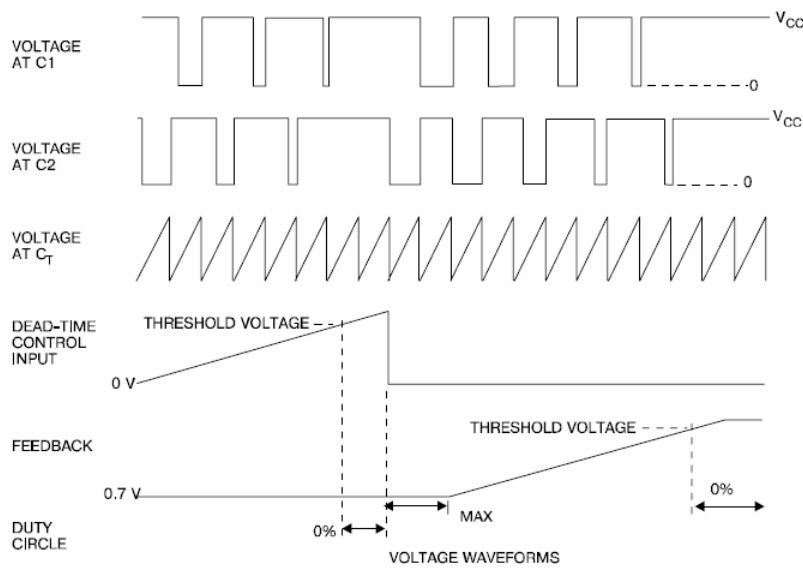
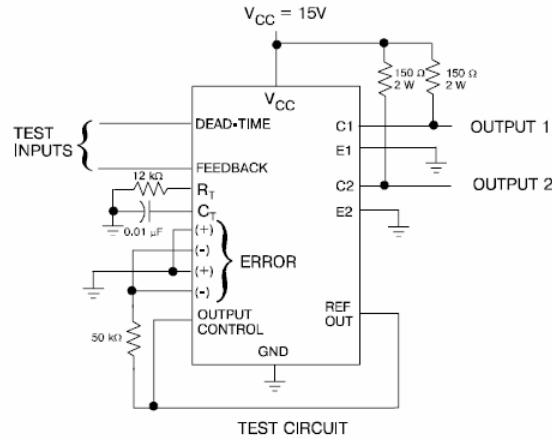

FIGURE 1. OPERATIONAL TEST CIRCUIT AND WAVEFORMS

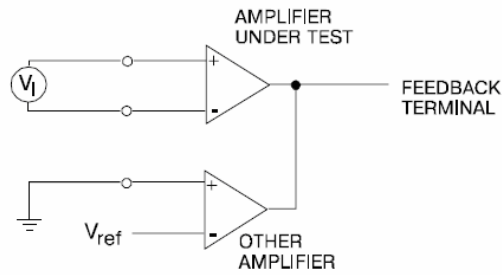

FIGURE 2. AMPLIFIER CHARACTERISTICS

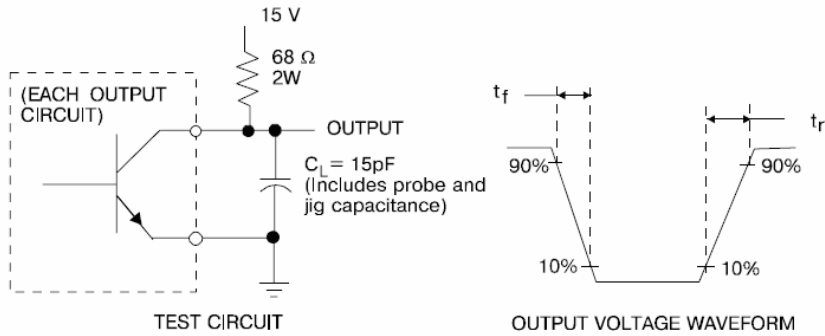

FIGURE 3. COMMON-EMITTER CONFIGURATION

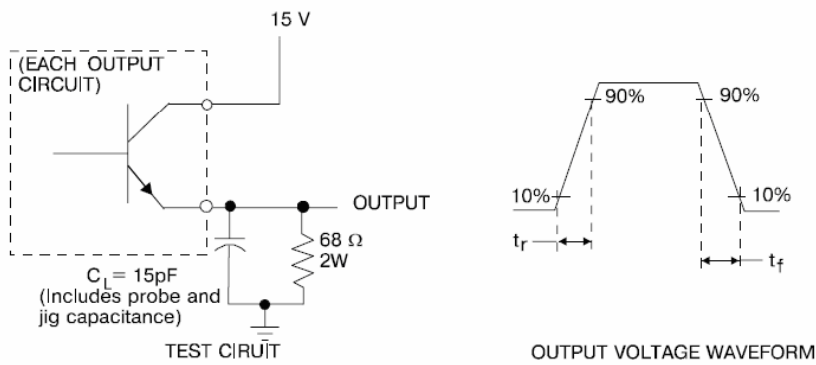

FIGURE 4. EMITTER-FOLLOWER CONFIGURATION

Electrical characteristics over recommended operating free-air temperature range, $V_{CC}=15V$, $f=10\text{ kHz}$ (unless otherwise noted).

Reference section

Parameter	Test conditions	Value			Unit
		MIN	TYP**	MAX	
Output voltage (V_{ref})	$I_O = 1\text{ mA}$	4.9	5	5.1	V
	$I_O = 1\text{ mA}, T_A=25^\circ\text{C}^{****}$	4.95	5	5.05	
Line regulation	$V_{CC} = 7V\text{ to }40V$		2	25	mV
Load regulation	$I_O = 1\text{ mA to }10\text{ mA}$		1	15	
Short-circuit output current***	$V_{ref} = 0$	10	35	50	mA

Oscillator section (see Figure 1)

Parameter	Test conditions*	Value			Unit
		MIN	TYP**	MAX	
Frequency	$C_T = 0.01\ \mu\text{F}, R_T = 12\text{ k}\Omega$	9.0	-	12	kHz
Frequency change with temperature *****	$C_T = 0.01\ \mu\text{F}, R_T = 12\text{ k}\Omega,$ $\Delta T_A = \text{MIN to MAX}$			2	%



Electrical characteristics over recommended operating free-air temperature range, $V_{CC}=15V$, $f=10\text{ kHz}$ (unless otherwise noted).

Amplifier section (see Figure 2)

Parameter	Test conditions	Value			Unit
		MIN	TYP**	MAX	
Input offset voltage	V_O (pin 3) = 2.5V		2	10	mV
Input offset current	V_O (pin 3) = 2.5V		25	250	nA
Input bias current	V_O (pin 3) = 2.5V		0.2	1	μA
Common-mode input voltage range	$V_{CC} = 7V$ to $40V$	-0.3 to $V_{CC}-2$			V
Open-loop voltage amplification	$\Delta V_O = 3V$, $R_L = 2k\Omega$, $V_O = 0.5$ to $3.5V$	70	95		dB
Unity-gain bandwidth			650		kHz

Output section

Parameter	Test conditions	Value			Unit
		MIN	TYP**	MAX	
Collector off-state current	$V_{CE}=40V$, $V_{CC}=40V$		2	100	μA
Emitter off-state current	$V_{CC}=V_C=40V$, $V_E=0$			-100	μA
Collector-emitter saturation voltage	Common-emitter		1.1	1.3	V
	Emitter-follower		1.5	2.5	
Output control input current	$V_I=V_{ref}$			3.5	mA

Dead-time control-section (see Figure 1)

Parameter	Test conditions	Value			Unit
		MIN	TYP**	MAX	
Input bias current (pin 4)	$V_I=0$ to $5.25V$		-2	-10	μA
Maximum duty cycle, each output	V_I (pin 4)=0, O. C.= V_{ref}	45			%
Input threshold voltage (pin 4)	Zero duty cycle		3	3.3	V
	Maximum duty cycle	0			

PWM comparator section (see Figure 1)

Parameter	Test conditions	Value			Unit
		MIN	TYP**	MAX	
Input threshold voltage (pin 3)	Zero duty cycle		4	4.5	V
Input sink current (pin 3)	V (pin 3) = 0.7V	0.3	0.7		mA

Total device

Parameter	Test conditions	Value			Unit
		MIN	TYP**	MAX	
Standby supply current	Pin 6 at V_{ref} , $V_{CC}=15V$		6	10	mA

Switching characteristics, $T_A = 25^\circ\text{C}$

Parameter	Test conditions	Value			Unit
		MIN	TYP**	MAX	
Output voltage rise time	Common-emitter configuration,		100	200	ns
Output voltage fall time	See figure 3		25	100	
Output voltage rise time	Emitter-follower configuration.		100	200	
Output voltage fall time	See Figure 4		25	100	

* For conditions shown as MIN or MAX, use the appropriate value specified under recommended operating conditions.

** All typical values except for parameter changes with temperature are at $T_A = 25^\circ\text{C}$

*** Duration of the short-circuit should not exceed one second

**** This is guaranteed where the marking code on the package surface is #AB

***** Temperature coefficient of timing capacitor and timing resistor not taken into account



Typical Application

Pulse Width Modulated Step-down Converter

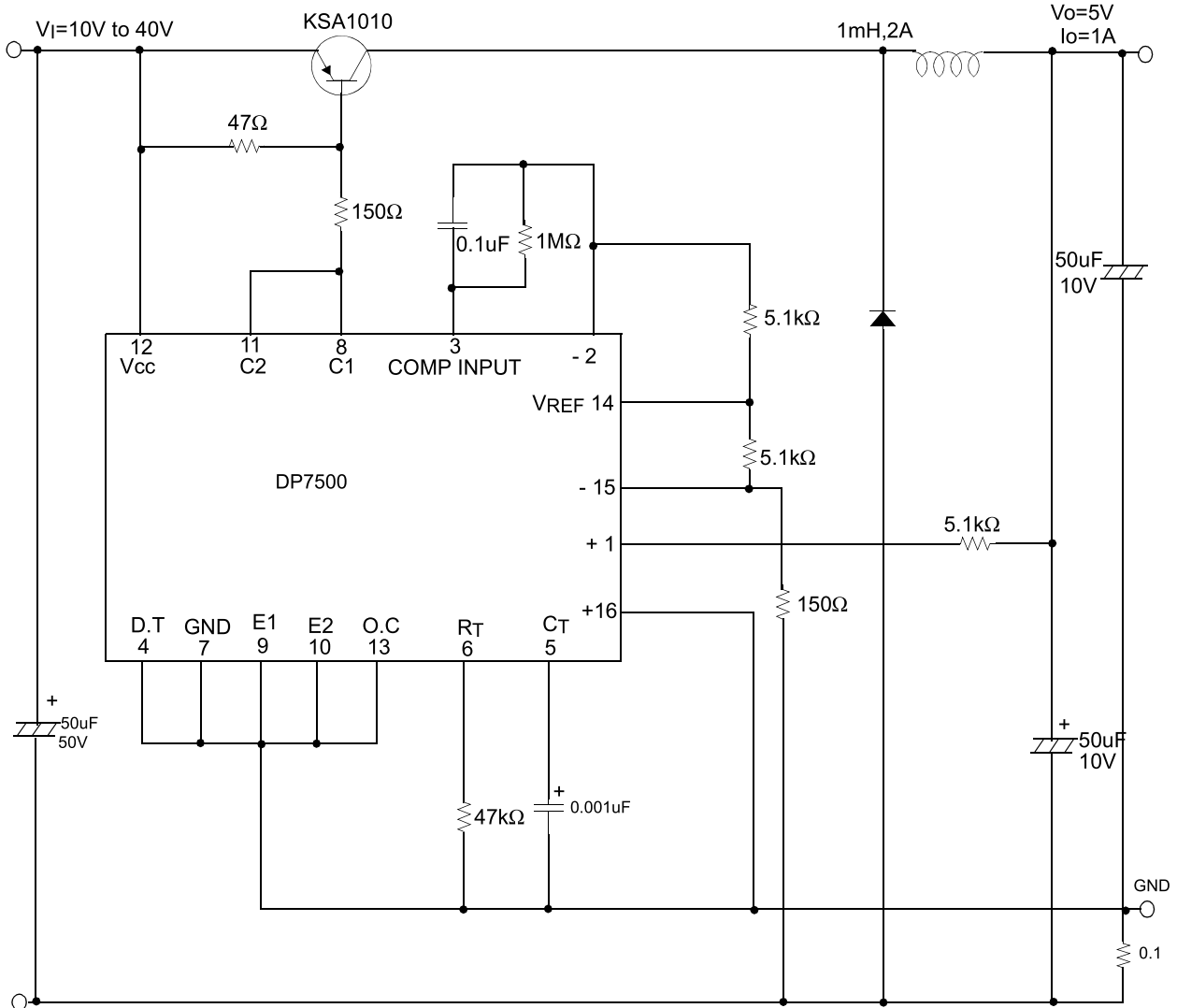



Mechanical Dimensions

Package

16-DIP

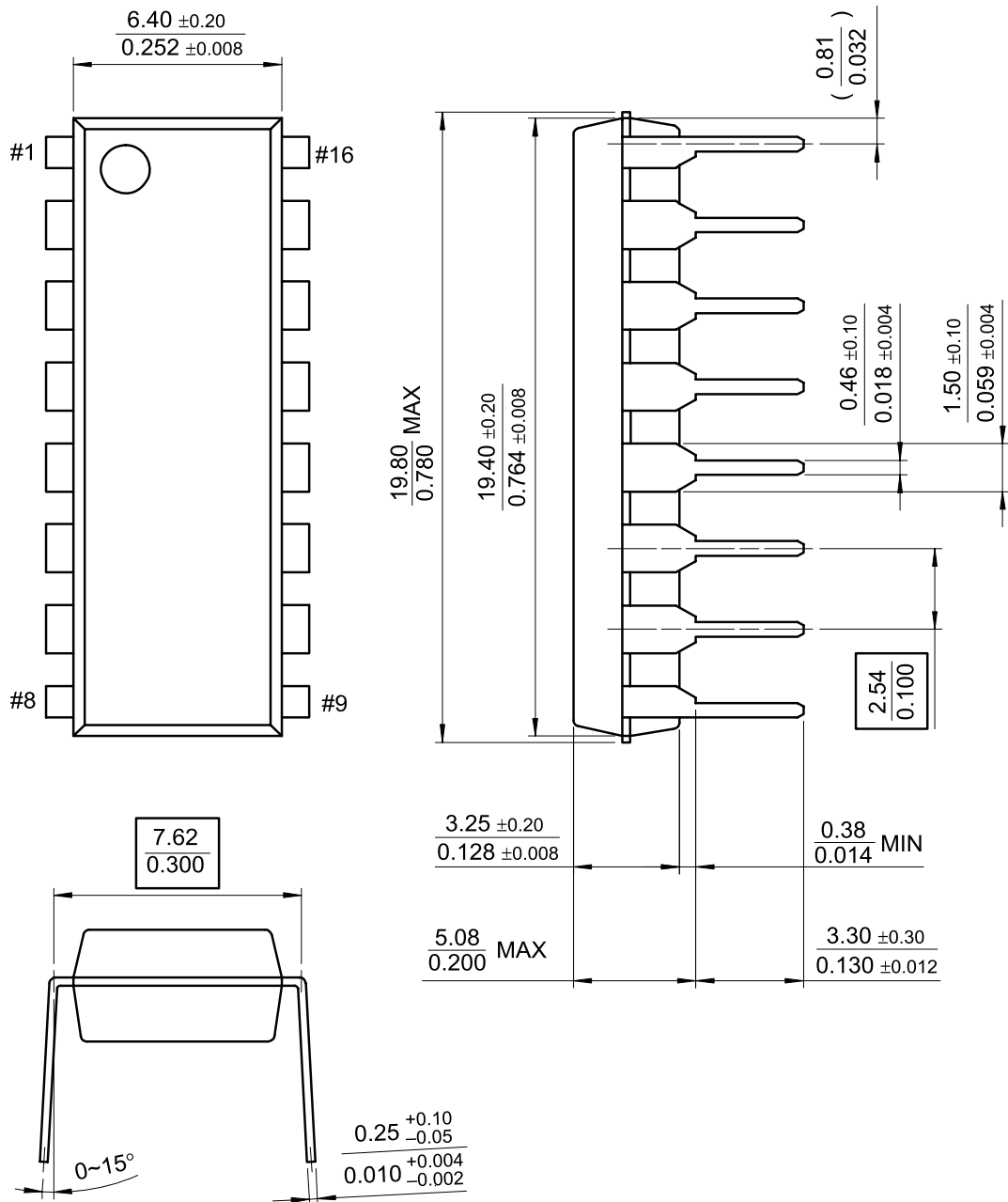



Mechanical Dimensions (Continued)

Package

16-SOP

